

INSTALLATION INSTRUCTIONS FOR OPTIMA® SYSTEM SENSOR ACTIVATED SLOAN® EXPOSED WITH TRUE MECHANICAL OVERRIDE FLUSHMETERS



MODEL 110/111



MODEL 186

Exposed Closet Flushometers 1-1/2" Top Spud

- Model 110/111 ES-S TMO
- Model 113 ES-S TMO
- Model 115 ES-S TMO
- Model 116 ES-S TMO

Exposed Urinal Flushometers 3/4" Top Spud

- Model 186 ES-S TMO

Exposed Urinal Flushometers 1-1/4" Top Spud

- Model 180 ES-S TMO



LIMITED WARRANTY

Unless otherwise noted, Sloan Valve Company warrants this product, manufactured and sold for commercial or industrial uses, to be free from defects in material and workmanship for a period of three (3) years (one (1) year for special finishes, SF faucets, PWT electronics and 30 days for PWT software) from date of first purchase. During this period, Sloan Valve Company will, at its option, repair, replace, or refund the purchase price of any product which fails to conform with this warranty under normal use and service. This shall be the sole and exclusive remedy under this warranty. Products must be returned to Sloan Valve Company, at customer's cost. No claims will be allowed for labor, transportation or other costs. This warranty extends only to persons or organizations who purchase Sloan Valve Company's products directly from Sloan Valve Company for purpose of resale. This warranty does not cover the life of the batteries.

THERE ARE NO WARRANTIES WHICH EXTEND BEYOND THE DESCRIPTION ON THE FACE HEREOF. IN NO EVENT IS SLOAN VALVE COMPANY RESPONSIBLE FOR ANY CONSEQUENTIAL DAMAGES OF ANY MEASURE WHATSOEVER.

VALVE ROUGH-IN

MODEL 110/111/113/115/116

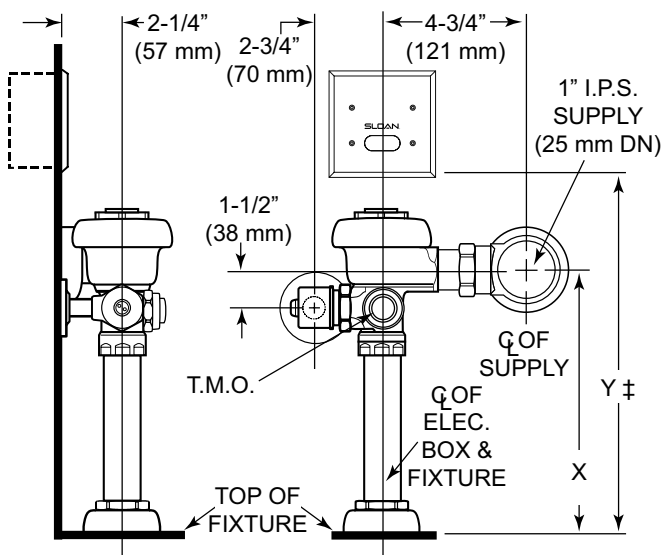

X VACUUM BREAKER SIZES VARIES ON MODEL FROM TOP OF FIXTURE TO C/L OF SUPPLY
 MODEL 110/111 - 11 1/2" (292 mm)
 MODEL 113 - 23 1/2" (597 mm)
 MODEL 115 - 24" (610 mm)
 MODEL 116 - 27" (686 mm)

Y SENSOR PLACEMENT VARIES ON MODEL FROM TOP OF FIXTURE TO BOTTOM OF SENSOR PLATE
 MODEL 110/111 - 19" (483 mm)
 MODEL 113 - 16" (406 mm)
 MODEL 115 - 14" (365 mm)
 MODEL 116 - 17" (432 mm)

‡ POSITION OF SENSOR BOX CAN BE RAISED OR LOWERED 1" (25 mm) IF IN CONFLICT WITH HANDICAP GRAB BARS.

MODEL 186

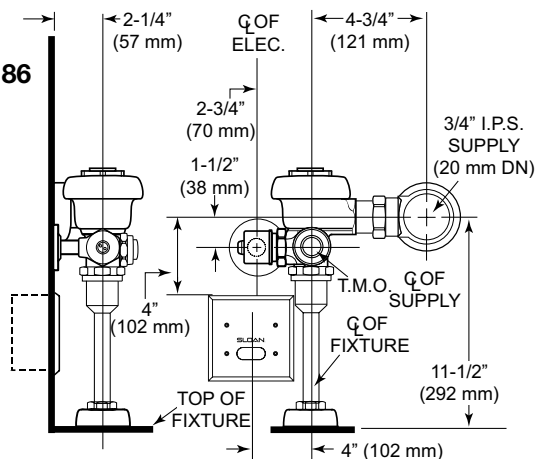

MODEL 180

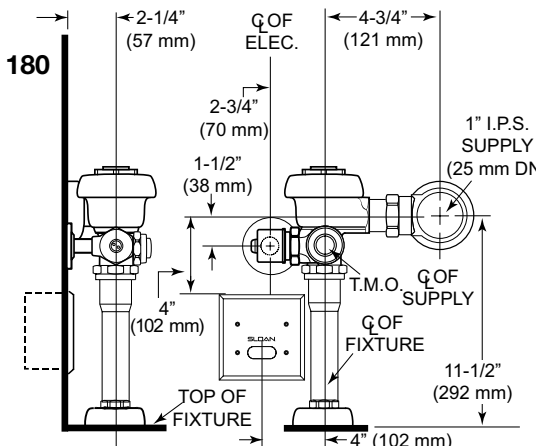

PRIOR TO INSTALLATION

Prior to installation, install the items listed below.

- Electrical wiring to the transformer box (120 VAC, 2 amp service required for each EL-154, 24 VAC, 50 VA transformer used)
- Closet fixture
- Water supply line
- Drain line

IMPORTANT:

- **ALL PLUMBING AND ELECTRICAL WIRING SHOULD BE INSTALLED IN ACCORDANCE WITH APPLICABLE CODES AND REGULATIONS.**
- **WATER SUPPLY LINES MUST BE SIZED TO PROVIDE AN ADEQUATE VOLUME OF WATER FOR EACH FIXTURE.**
- **A 24 VAC STEP-DOWN TRANSFORMER MUST BE USED.**
- **WHEN INSTALLING A FLUSHOMETER, IT IS IMPORTANT THAT THE FLUSH MODEL MATCHES THE REQUIREMENTS OF THE PLUMBING FIXTURE.**

- **FLUSH ALL WATER LINES PRIOR TO MAKING CONNECTIONS.** Sloan flushometers are designed to operate with flowing pressure 15 to 100 psi (104 to 689 kPa) of water pressure. **THE MINIMUM PRESSURE REQUIRED TO THE VALVE IS DETERMINED BY THE TYPE OF FIXTURE SELECTED.** Consult fixture manufacturer for minimum pressure requirements.

Most Low Consumption water closets (1.6 gallon/6.0 liter) require a minimum flowing pressure of 25 psi (172 kPa).

Protect the chrome or special finish of this flushometer — **DO NOT USE TOOTHED TOOLS TO INSTALL OR SERVICE THE VALVE.** Also, see “Care and Cleaning” section of this manual.

IMPORTANT: EXCEPT FOR CONTROL STOP INLET, DO NOT USE PIPE SEALANT OR PLUMBING GREASE ON ANY VALVE COMPONENT OR COUPLING!

TRANSFORMER INSTALLATION

Install transformer (EL-154) on a 2-gang electrical box, 4" x 4" x 2½" (102 mm x 102 mm x 64 mm) in a convenient location; refer to the illustration.

Note: One Sloan EL-154 transformer can operate up to ten OPTIMA equipped flushometers. Run 18-gauge wire from transformer to flushometer(s). Wire supplied by others. **DO NOT** supply power to transformer until installation of flushometer is complete.

NOTE: A maximum of ten (10) flushometer units can operate from one (1) Sloan EL-154 transformer, Class 2, UL Listed, 50 VA (min.) at 24 VAC, plate mounted.

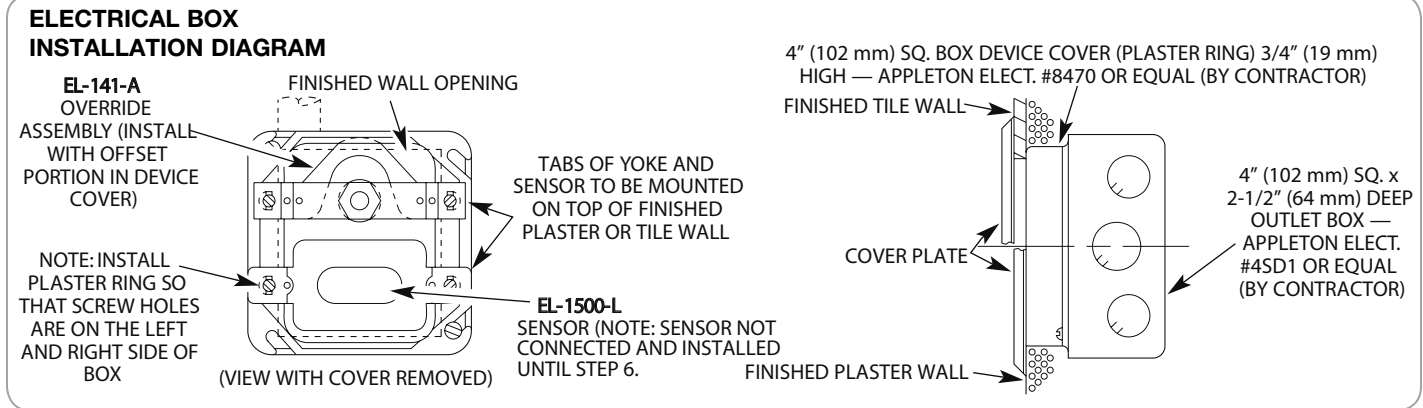

SENSOR/SOLENOID OPERATOR BOX LOCATIONS

Optima ES-S flushometer exposed True Mechanical Override closet model employs one (1) electrical box. Refer to rough-in illustrations for locations.

NOTE: Install plaster ring so screw holes are on left and right side of box.

NOTE: Break tiles to allow screw holes in plaster to show.

TOOLS REQUIRED FOR INSTALLATION

- Sloan A-50 Super-Wrench™, Sloan A-109 Plier Wrench or smooth jawed spud wrench
- 5/64" hex wrench (supplied)
- Slotted screwdriver
- Wire stripper/crimping tool

!!! IMPORTANT !!!

Protect the chrome or special finish of Sloan Flushometers — **DO NOT USE** toothed tools to install or service these valves. Use a Sloan A-50 Super-Wrench™, Sloan A-109 Plier Wrench or smooth jawed spud wrench to secure all couplings. Also see “Care and Cleaning” section of this manual.

!!! IMPORTANT !!!

This product contains mechanical and/or electrical components that are subject to normal wear. These components should be checked on a regular basis and replaced as needed to maintain the valve's performance.

!!! IMPORTANT !!!

With the exception of Control Stop Inlet, **DO NOT** use pipe sealant or plumbing grease on any valve component or coupling!

!!! IMPORTANT !!!

Never open Control Stop to where the flow from the valve exceeds the flow capability of the fixture. In the event of a valve failure, the fixture must be able to accommodate a continuous flow from the valve.

1 - INSTALL OPTIONAL SWEAT SOLDER ADAPTER (ONLY IF YOUR SUPPLY PIPE DOES NOT HAVE A MALE THREAD)

- A** Measure from finished wall to C/L of fixture spud. Cut pipe 1 1/4" (32 mm) shorter than this measurement. Chamfer O.D. and I.D. of water supply pipe.
- B** Slide threaded adapter fully onto pipe, until it bottoms out.
- C** Sweat solder the Adapter to pipe.

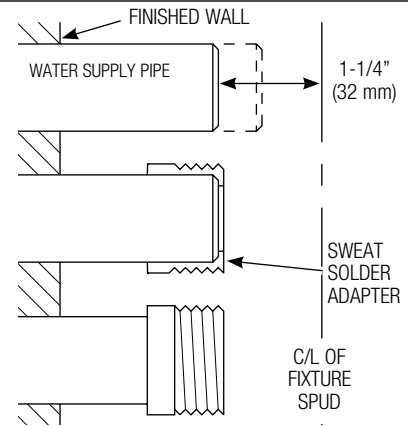

!!! IMPORTANT !!!

With the exception of control stop inlet, DO NOT use pipe sealant or plumbing grease on any valve component or coupling!

2 - INSTALL COVER TUBE, WALL FLANGE AND CONTROL STOP TO SUPPLY PIPE

- A** Measure from finished wall to first thread of adapter or threaded supply pipe (dimension "X"). Cut cover tube to this length.
- B** Slide cover tube over pipe. Slide wall flange over cover tube until against wall.
- C** Thread control stop onto water supply line. Tighten with a wrench making sure outlet is positioned as required.
- D** Tighten wall flange set screw with hex wrench. DO NOT install vandal resistant stop cap at this time.

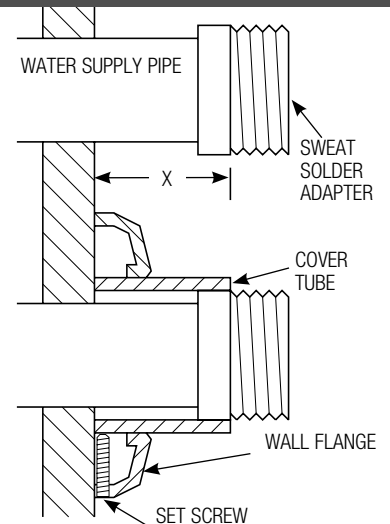
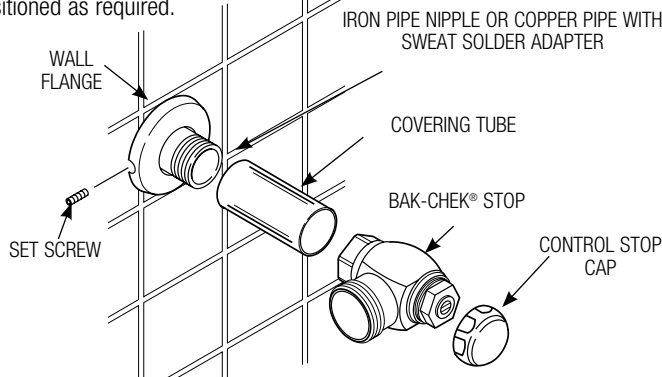

3 - INSTALL VACUUM BREAKER FLUSH CONNECTION AND BUTTON

- A** Assemble Pipe, Elbows, Couplings, Nylon Slip Gaskets, Rubber Gaskets and Flanges as illustrated.
- B** Insert Tube into Fixture Spud.
- C** Hand tighten all Couplings.

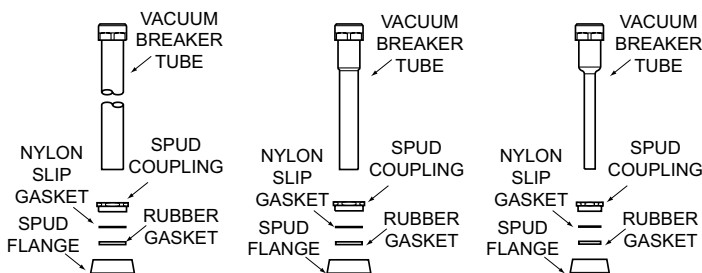

- D** Install True Mechanical Override Button into Flushometer.
- E** Install Valve Handle Cap on opening in back of valve body.

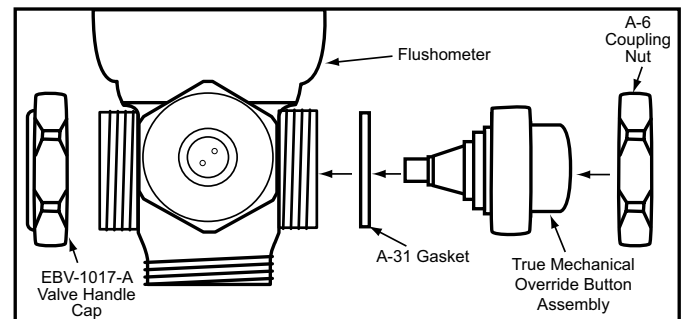

4 - INSTALL FLUSHOMETER

- A** Lubricate tailpiece o-ring with water. Insert adjustable tailpiece into control stop. Tighten tailpiece coupling by hand.
- B** Align flushometer directly above the vacuum breaker flush Connection by sliding the flushometer Body IN or OUT as needed. Tighten vacuum breaker coupling by hand.
- C** Align Flushometer Body and securely tighten first the Tailpiece Coupling (1), then the Vacuum Breaker and Pipe Couplings (2), and finally the Spud Coupling (3). Use a wrench to tighten these couplings in the order shown.

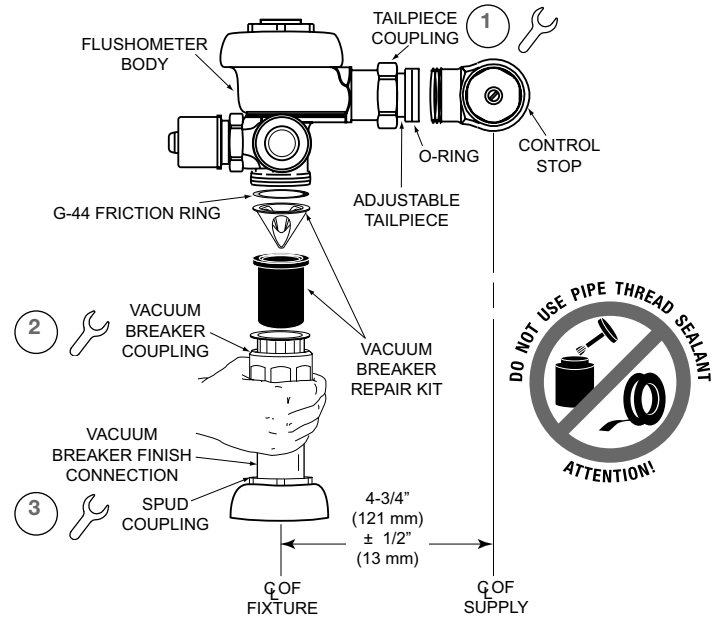

NOTE

Max. adjustment of Sloan Adjustable Tailpiece is 1/2" (13 mm) IN or OUT from the standard 4 3/4" (121 mm) (Q of Valve to Q of Control Stop).

If roughing-in measurement exceeds 5 1/4" (133 mm), consult factory for longer tailpiece.

5 - ELECTRICAL HOOK-UP

- A** Be certain power is OFF to prevent damage to electrical components. Connect Sensor to Transformer and Solenoid coil EXACTLY as shown.
- B** Connect 24 volt source lead to terminal labeled "24 VAC IN" of Sensor.
- C** Connect solenoid lead to terminal labeled "TO VALVE" of Sensor.
- D** Connect remaining solenoid lead to remaining 24 volt source lead.

Wiring Diagram for One Flush Valve

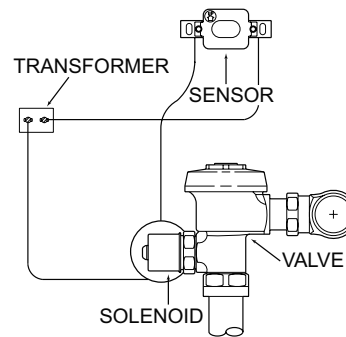

Wiring Diagram for Multiple Flush Valves

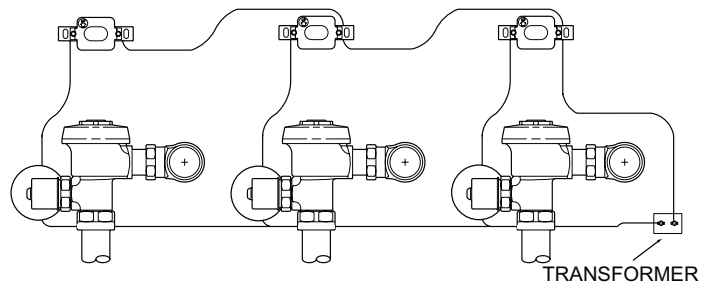

Wiring Diagram

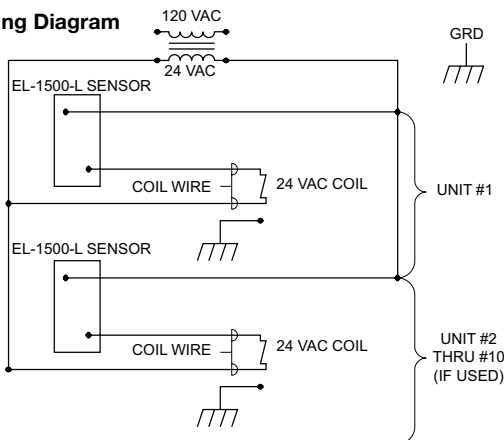

6 - INSTALL SENSOR COVER PLATE

- A** Install Optima sensor into the 2-gang electrical box using two (2) long screws provided. Ensure that sensor lens faces outward and horizontally from finished wall.
- B** Mount assembly yoke to electrical box.
- C** Install sensor cover plate and secure with tamper-proof screws.

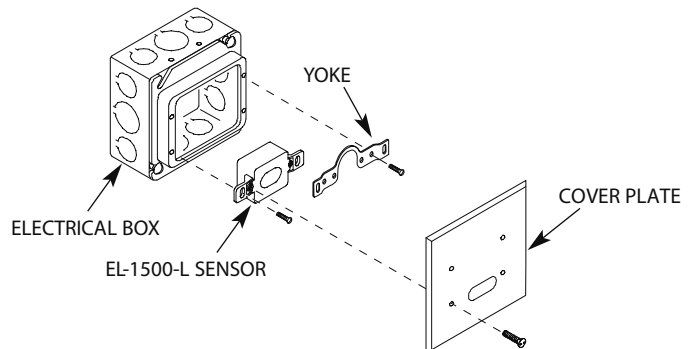

7 - INSTALL WALL FLANGE AND SECURE SOLENOID HOUSING AND COIL ASSEMBLY

- A** Locate flange on wall at dimensions shown.

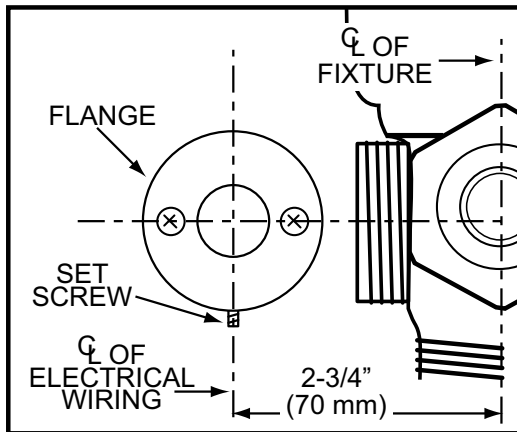

- B** Drill hole to pass wires through.
C Mount flange to wall using screws and anchors provided.
D Pull wires from transformer and sensor through flange into room.
E Install F-15 Tail Pipe to Solenoid Housing.

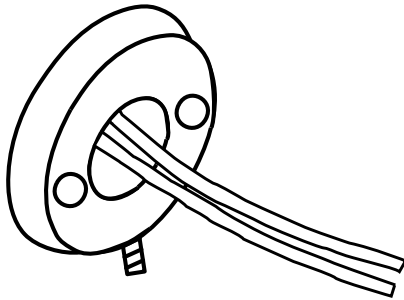

- F** Connect transformer and sensor wire leads to coil wire leads.
G Lubricate O-Ring seal of solenoid assembly with water.
H While feeding wires back into the wall, carefully insert the F-15 tail into the wall flange and install solenoid operator assembly to Flushometer. Loosen the housing retention nut as needed to aid in positioning the assembly.

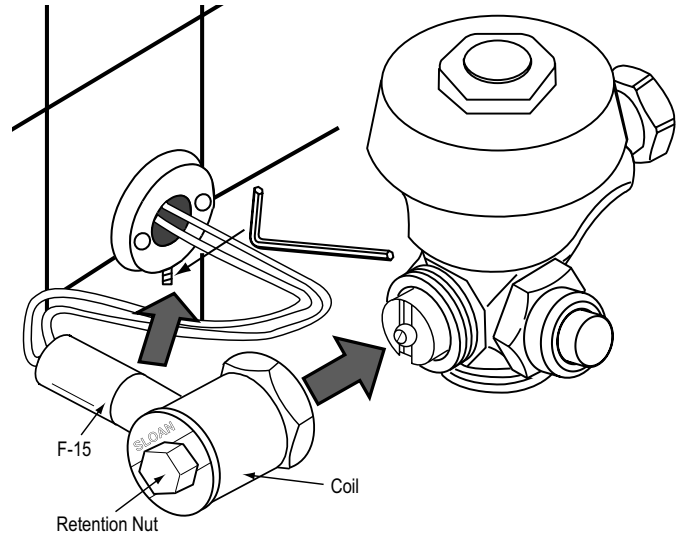

- I** Secure solenoid operator to Flushometer by tightening the solenoid coupling. Tighten housing retention nut.
J Secure flange set screw with provided hex key.

Important: Do not remove coil from solenoid plunger guide unless power has been disconnected. Failure to do so may damage sensor, coil and transformer.

8 - FLUSH OUT SUPPLY LINE

- A** Make sure Control Stop is CLOSED.
B Remove Flushometer Outer Cover, Inside Cover and lift out Relief Valve Assembly. Install Flushometer Inner Cover and Outer Cover, and wrench tight.
C Open Control Stop. Turn on water supply to flush line of any debris or sediment.
D Shut off Control Stop, remove Covers, remove diaphragm kit and flush under clean water.
E Reinstall Diaphragm Kit and Relief Valve Assembly. Reinstall Inside Cover. Thread on Outer Cover and wrench tight. Do Not open Control Stop until Step 13.

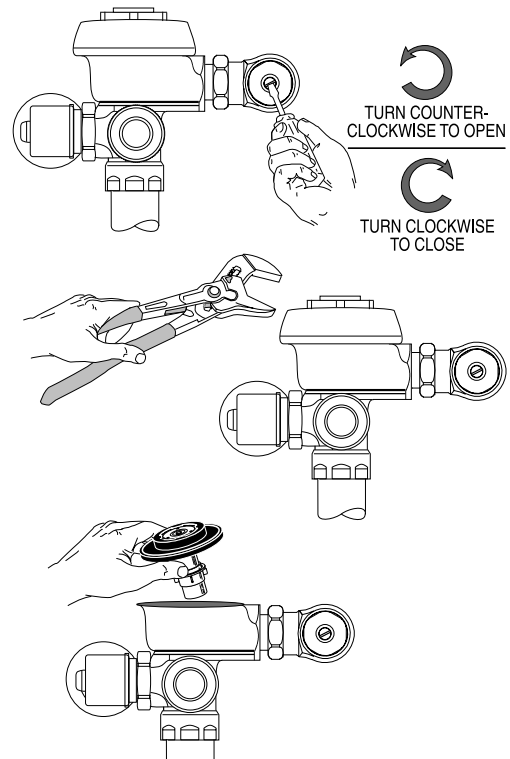

9 - POWER AND START-UP MODE

Note: It is recommended that all electronic connections be tested with the water supply OFF.

- A** Turn Power ON. The self adaptive sensor automatically adapts to the surrounding environment when 24 volt supply is activated. No manual adjustments are required.
- B** Start-up mode will take approximately five (5) minutes to complete its cycle and is important that no non-permanent target is present at this time. A continuous red light visible in sensor window indicates sensor is in the start-up mode. If the red light is flashing, this indicates that the sensor is picking up a target. Unless this target is a permanent fixture in the sensor's environment (i.e., a wall or stall door), it must be removed from the view of the sensor. If this target is permanent, the sensor will adapt itself around this target. In this case, the start-up mode may take up to ten (10) minutes. When the start-up cycle is completed, no light is visible in sensor window.

Note: If 24 volt power supply is interrupted at any time for more than fifteen (15) seconds, the start-up mode automatically repeats itself when power is restored.

- C** If indicator light flashes three (3) times slowly, three (3) times rapidly and again three (3) times slowly and continually repeats this signal, this indicates incorrect wiring or a short in the 24 volt supply. The EL-1500 Series Sensors self-adaptive sensor is equipped with the sentinel flush feature (automatically flushes Flushometer every twenty-four (24) hours after last use).

10 - DETECTION / ACTIVATION

- A** When an object is detected, a slowly flashing red light will appear in the sensor window. After approximately eight (8) to ten (10) seconds, the light will flash rapidly indicating sensor is armed and ready to activate solenoid when the object leaves the detection area. The solenoid will be activated within two (2) to four (4) seconds after non-detection.

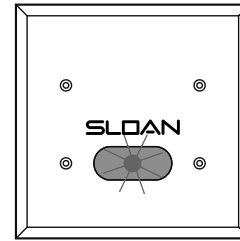

11 - TURN WATER ON AND ADJUST CONTROL STOP

- A** Adjust Control Stop to meet the flow rate required for proper cleansing of the fixture. Open Control Stop COUNTERCLOCKWISE one (1) FULL turn from the closed position.

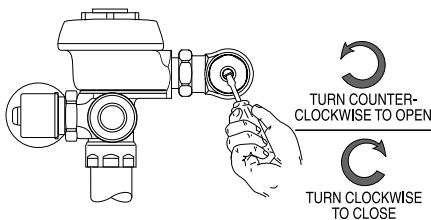

- C** Adjust Control Stop after each flush until the rate of flow delivered properly cleanses the fixture.

!!! IMPORTANT !!!

All Sloan Flushometers are engineered for quiet operation. Excessive water flow creates noise, while too little water flow may not satisfy the needs of the fixture. Proper adjustment is made when plumbing fixture is cleansed after each flush without splashing water out from the lip AND a quiet flushing cycle is achieved.

Never open Control Stop to where the flow from the valve exceeds the flow capability of the fixture. In the event of a valve failure, the fixture must be able to accommodate a continuous flow from the valve.

- B** Activate Flushometer by placing hand in front of OPTIMA Sensor Lens for ten (10) seconds and then moving it away.

OPERATION

1. A continuous, invisible light beam is emitted from the OPTIMA Sensor.

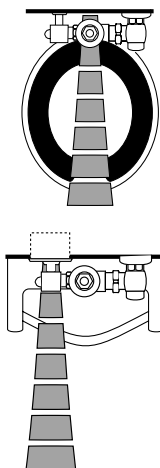

2. When a user enters the beam's effective range, for water closets 22" - 42" (559 mm - 1067 mm) and for urinals 15" - 30" (381 mm - 762 mm), the beam is reflected into the OPTIMA's scanning window and transformed into a low voltage electrical signal that activates a ten-second time delay circuit. The time delay circuit eliminates false operation from passers-by in the rest room. Once the time delay is completed, the output circuit is alerted and continues in a "hold" mode for as long as the user remains within the effective range of the sensor.

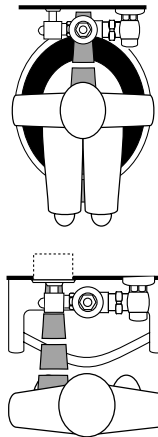

3. When the user steps away from the OPTIMA Sensor, the loss of reflected light initiates an electrical "one-time" signal that energizes the Solenoid Operator, and activates the Flushometer to flush the fixture. This occurs on the water closet approximately three (3) seconds after indication. This delay is built into the Sensor to help prevent false flushing due to movement by the user. The circuit for both water closets and urinals then automatically resets and is ready for the next user.

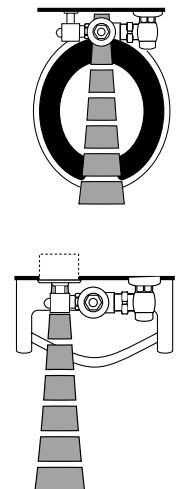

TROUBLESHOOTING GUIDE

NOTE: Upon detection of the user, the red indicator light flashes slowly for a period of eight (8) seconds. When the user leaves the detection range, stops flashing the Sensor locks to flush inside and initiates the flush sequence. At which time it flashes rapidly indicating a target has been acquired. And the valve flushes after a three (3) second delay.

- 1.PROBLEM:** Valve does not function (red light does not flash when user steps in front of sensor).
- CAUSE:** No power is being supplied to sensor.
- SOLUTION:** Ensure that the main power is turned "ON." Check transformer, leads and connections. Repair or replace as necessary.
- CAUSE:** EL-1500 Series Sensor is not operating.
- SOLUTION:** Replace EL-1500 Series Sensor.
- 2.PROBLEM:** Valve does not function (red light flashes when user steps in front of Sensor).
- INDICATOR:** Red light stops flashing when user steps away and valve makes a "clicking" sound but does not flush.
- CAUSE:** No water is being supplied to the valve.
- SOLUTION:** Make certain that water supply is turned "ON" and the Control Stop is open.
- CAUSE:** EL-128-A cartridge is fouled or jammed.
- SOLUTION:** Turn electronic power to valve "OFF" (failure to do so could result in damage to the solenoid coil). Remove the solenoid operator from the valve and remove the EL-128-A cartridge. Clean and/or repair as necessary.
- INDICATOR:** The red light stops flashing when user steps away but the valve does NOT make a "clicking" sound and does NOT flush.
- CAUSE:** EL-163-A solenoid shaft assembly is fouled or jammed.
- SOLUTION:** Turn electronic power to valve "OFF" (failure to do so could result in damage to the solenoid coil). Remove EL-101 or EL-166 nut from the solenoid operator. Remove the coil from the solenoid operator. Use a spanner wrench or pliers to remove the EL-163-A solenoid shaft assembly from valve. Clean and/or replace as necessary. Be sure to replace plunger spring when reassembling Solenoid Shaft Assembly.
- INDICATOR:** The red light flashes three (3) short flashes, three (3) long flashes then three (3) short flashes ("S-O-S") and continues to repeat this cycle even when user steps out of the sensor's detection range.
- CAUSE:** EL-1500 Series Sensor wiring connections are incorrect.
- SOLUTION:** Rewire Sensor to valve. One solenoid lead connects to the "TO VALVE" connection on Sensor. One transformer lead connects to the "24 VAC IN" connection on Sensor. Second solenoid lead and second transformer lead connect together.
- CAUSE:** Wiring to Sensor is ground shorted.
- SOLUTION:** Find short in wiring circuit and correct.
- CAUSE:** EL-165-2 solenoid coil is burnt out or coil is not connected to solenoid plunger shaft.
- SOLUTION:** Reinstall or replace coil as necessary.

- 3.PROBLEM:** Volume of water is insufficient to adequately siphon fixture.
- CAUSE:** Control Stop is not open wide enough.
- SOLUTION:** Adjust control stop for desired water delivery.
- CAUSE:** Low Consumption unit is installed on Water Saver or Conventional fixture.
- SOLUTION:** Replace Diaphragm component parts of valve with kit that corresponds to appropriate flush volume of fixture.
- CAUSE:** Inadequate water volume or pressure available from supply.
- SOLUTION:** Increase pressure or supply (flow rate) to the valve. Consult factory for assistance.
- 4.PROBLEM:** Length of flush is too long (long flushing) or valve fails to shut off.
- CAUSE:** Water Saver valve is installed on Low Consumption fixture.
- SOLUTION:** Replace Diaphragm component parts of valve with kit that corresponds to appropriate flush volume of fixture.
- CAUSE:** Relief valve in diaphragm is not seated properly or bypass hole in diaphragm is clogged.
- SOLUTION:** Disassemble inside Diaphragm component parts and wash parts thoroughly. Replace worn parts if necessary.
- 5.PROBLEM:** Water splashes from fixture.
- CAUSE:** Supply flow rate is more than necessary.
- SOLUTION:** Adjust Control Stop to meet flow rate required for proper cleansing of the fixture.

If further assistance is required, please contact
Sloan Tech Supportat:

1-888-SLOAN-14 (1-888-756-2614)

CARE AND CLEANING

DO NOT use abrasive or chemical cleaners to clean flushometers that may dull the luster and attack the chrome or special decorative finishes of flushometer components. Use ONLY soap and water, then wipe dry with clean cloth or towel.

While cleaning the fixture, protect the exposed flushometer from any splattering of cleaner. Acids and cleaning fluids can discolor or remove chrome plating.

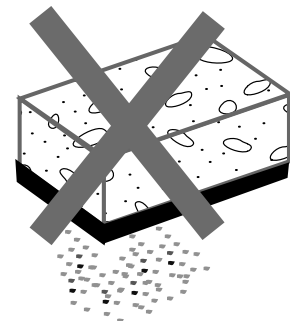

PARTS LIST

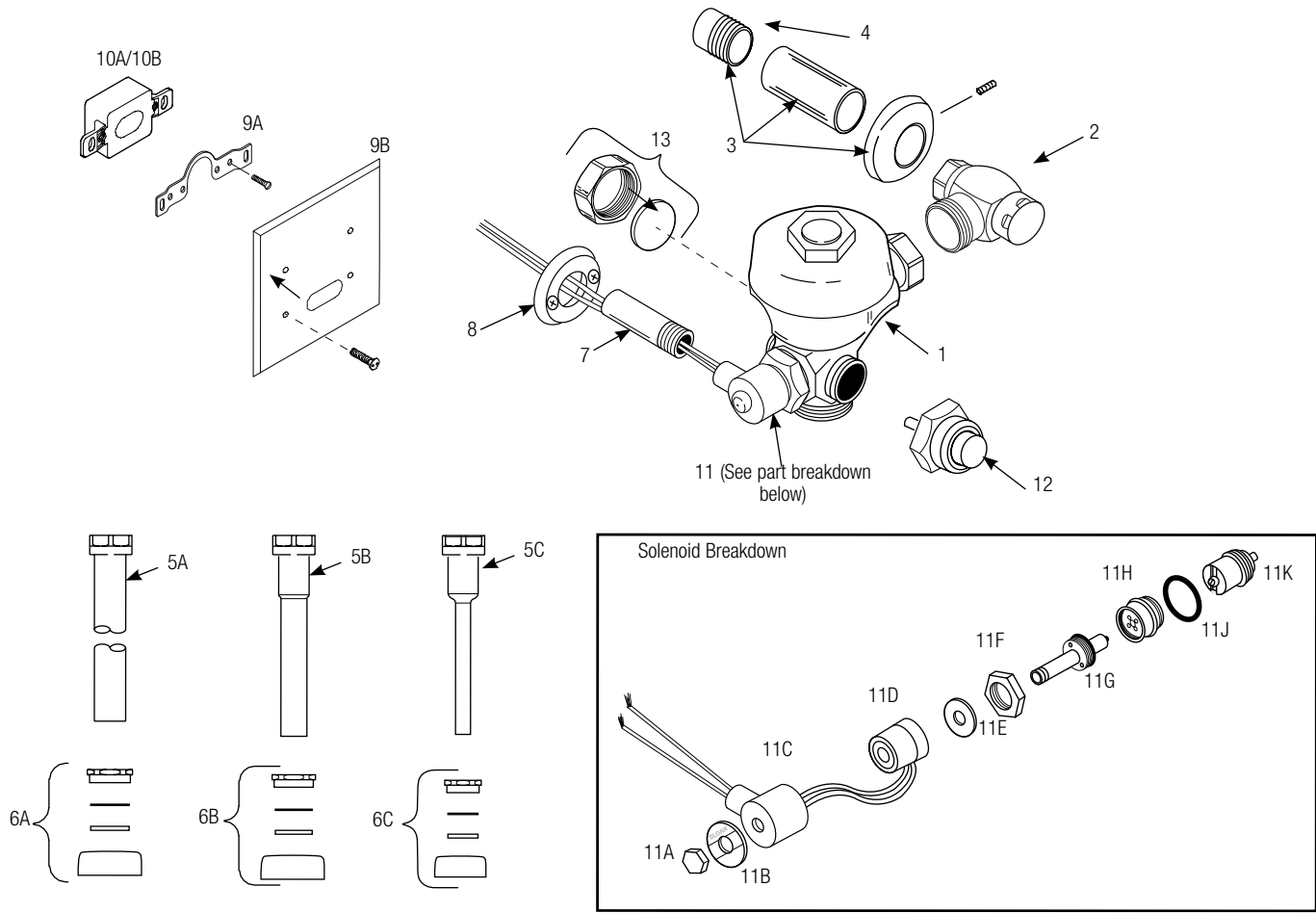

Item No.	Part No.	Description
1	‡	Solenoid Operated Valve Assembly
2	H-700-A ‡	Bak-Chek® Control Stop
3	H-633-AA	1" (25 mm) Sweat Solder Kit
4	H-532	Adapter, 1" NPT to 1" Tube (Concealed)
	H-535	Adapter, ¾" NPT to ¾" Tube (Concealed)
5A	V-500-AA	1½" (38 mm) CP Vacuum Breaker Assembly† (Models 110/111, 113, 115, and 116)
5B	V-500-AA	1¼" (32 mm) x 9" (229 mm) CP Vacuum Breaker Assembly (Model 180 ES-S)
5C	V-500-AA	¾" (19 mm) x 9" (229 mm) CP Vacuum Breaker Assembly (Model 186 ES-S)
6A	F-56-A	1½" (38 mm) Spud Coupling Assembly CP (Models 110/111, 113, 115, and 116)
6B	F-55-A	1¼" (32 mm) Spud Coupling Assembly CP (Model 180)
6C	F-54-A	¾" (19 mm) Spud Coupling Assembly CP (Model 186)
7	F-15	Tail Assembly
8	B-110-A	Flange Assembly
9A	EL-168-A	Yoke Assembly
9B	EL-161	CP Sensor Cover Plate
10A	EL-1500-L	Sensor (Models 110/111, 113, 115, and 116)
10B	EL-1500	Sensor (Models 180 and 186)

Item No.	Part No.	Description
11	EL-124-2	CP 24V Solenoid Assembly
11A	EL-101	CP Nut for Solenoid
11B	EL-102-2	Face Plate for 24V Solenoid
11C	EL-162-2	CP 24V Solenoid Housing
11D	EL-165-2	24V Coil
11E	EL-164	Solenoid Flux Plate
11F	A-6	CP Handle Coupling
11G	EL-163-A	Solenoid Shaft Assembly Includes Gasket, Plunger, Plunger Spring, and Solenoid Shaft
11H	EL-104	Adapter for Solenoid
11J	D0-22	O-Ring
11K	EL-128-A	Actuator Cartridge Assembly Repair Kit Includes Spring, Plunger Guide, Solenoid Valve Seat, Valve Piston Assembly, and O-Ring
12	C-2-A	True Mechanical Override Button
13	EBV-1017-A	CP Valve Handle Cap

‡ Part number varies with valve model variation; consult factory.
 † Height varies with valve model variation; consult factory.

The information contained in this document is subject to change without notice.