

# SharkBite® Heatguard® 160 Series

## DESCRIPTION

The Heatguard® 160 is a next generation Temperature Actuated Mixing Valve that mixes hot water with cold to deliver tempered water at a controlled temperature. The Heatguard 160 is designed to assist in prevention of scalding and thermal shock.

The Heatguard 160 is intended to control the water temperature to individual or multiple fixtures such as sinks, lavatories, or bath tubs to reduce the risk of scalding and thermal shock. It can also be installed in gang shower applications where the bather has no access to the temperature adjustment means.

The Heatguard 160 is a high specification product incorporating the latest in Thermostatic Technology. It features a robust design based on the expertise gained from years of experience in the design and manufacture of safety valves. Every valve is tested for performance on an automated testing station during the assembly process. The valve is third party listed for individual point-of-use applications.

The Heatguard 160 features a rapid response thermostatic element for superior control. The thermostatic element senses the outlet water temperature and reacts to maintain a constant delivery temperature even under changing flows or variations in supply temperatures or pressures. The valve also reduces the outlet flow to a trickle in the event of a cold water supply failure.

The Heatguard 160 features a snap-on cover over a spindle mechanism that requires a special tool to adjust the temperature. This special tool is provided with each valve.

The Heatguard 160 is shipped complete as a kit with SharkBite® connections. All valves are supplied standard with check valves.



24529



## FEATURES AND BENEFITS

Every valve is tested for performance prior to shipping:  
*Specify and install with confidence!*

Accurate temperature control, even under varying supply conditions:  
*Increased user comfort and convenience.*

Robust, low complexity construction:  
*Superior reliability, improved user safety.*

Total flow shut-off if cold supply fails:  
*Greater end user safety.*

Unique, purpose designed adjuster tool:  
*Minimizes unauthorized tampering with valve setting.*

Listed by ASSE and IAPMO:  
*Inspector friendly, peace of mind!*

## SPECIFICATIONS

A Temperature Actuated Mixing Valve shall be installed to individual fixtures such as sinks, lavatories, or bath tubs; or multiple fixtures such as gang shower applications where the bather has no access to the temperature adjustment means; to reduce the risk of scalding and thermal shock. The valve shall be certified to ASSE 1069, ASSE 1070 and CSA B 125.3 standards and shall be listed by a third party. The temperature actuated mixing valve shall control the delivered water temperature via a regulating piston made from engineered polymer. A special tool shall be required to adjust the outlet temperature and the adjusting mechanism shall be hidden by a snap-on-cover. The valve shall be a Cash Acme® Heatguard 160 LF with SharkBite connections.



## TYPICAL INSTALLATION

The Heatguard 160 is a high performance Thermostatic Mixing Valve designed to control the water temperature to individual or multiple fixtures such as sinks, lavatories, or bath tubs to reduce the risk of scalding and thermal shock. It can also be installed in gang shower applications where the bather has no access to the temperature adjustment means.

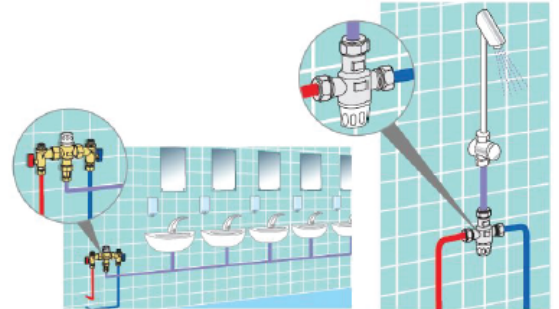
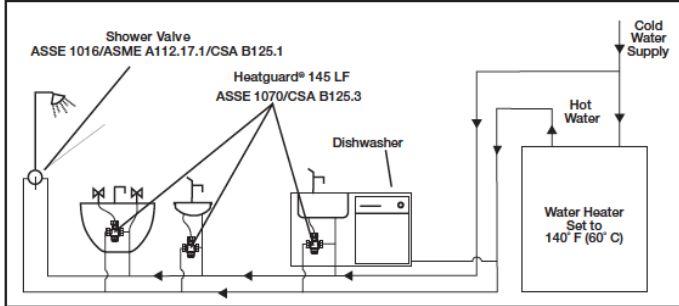

## SPECIFICATION DATA

### Performance:

Adj. outlet temperature range .....	95 – 120°F (35 – 48.9°C)
Factory set temperature range .....	115 - 120°F (46.1 – 48.9°C)
Temp. hot supply .....	120 – 180°F (48.9 – 82.2°C)
Temp. cold supply .....	39 – 80°F (3.9 – 26.7°C)
Maximum pressure .....	145 psi (1000 kPa)
Flow rate, minimum .....	0.34 gpm (1.3 l/min)
Flow rate, maximum .....	11 gpm (42 l/min)

### Materials:

Body .....	Bronze
Seals .....	EPDM
Springs .....	Stainless Steel
Internal cap .....	Brass
Piston .....	Engineered Polymer
Guide tube .....	Noryl GFN2

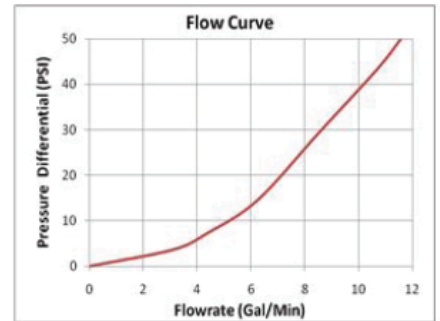

## AVAILABLE CONNECTIONS

SharkBite® ..... 1/2" and 3/4"

## CERTIFICATIONS

The SharkBite® Heatguard® 160 LF is certified to ASSE 1069, ASSE 1070, CSA B125.3, NSF/ANSI 61, NSF 372. The SharkBite fittings are certified to ASSE 1061. The valve is listed by ASSE and IAPMO for use in accordance with U.S. and Canadian plumbing codes.

