

Series 110

Pressure Balance Tub and Shower Set

1.110868

(1.110868T - Trim Only)

Stella X Handle

Euro Style 20 pt.

FEATURES:

- Solid brass construction
- Valve cartridge: 18.30.893
- Diverter assembly: 18.30.894
- Screwdriver stop: 18.30.895
- Adjustable hot limit safety stop
- Reversible cartridge
- 5.0 GPM @ 60 PSI
- Certified to meet or exceed the following codes and standards:
ASME A112.18.1/CSAB 125.1-2012

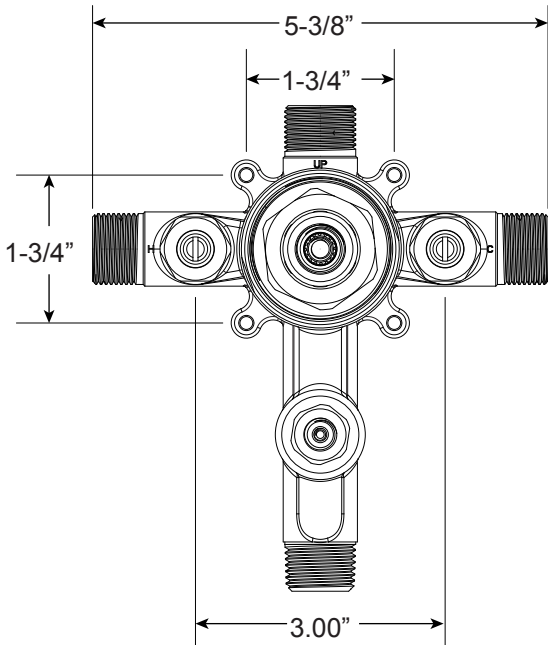

FRONT VIEW

Note: Stem and all-thread tube will be sent with handle trim.

SIDE VIEW

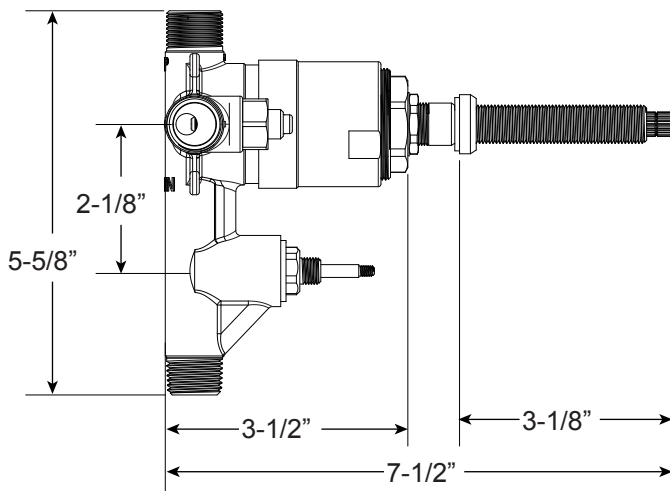

Current valve in use:
Circa 4/2014 - present
Contact Customer Service
for Older Versions

For additional information on
cartridges or extension kits,
see 'Rough Valving' section
in current catalog.

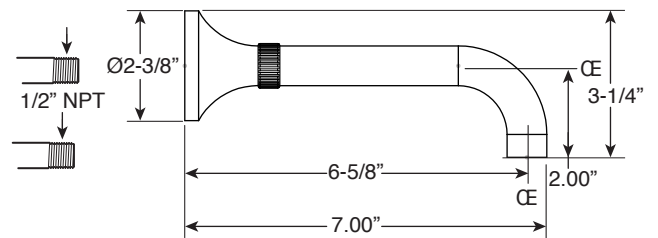
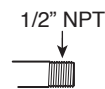
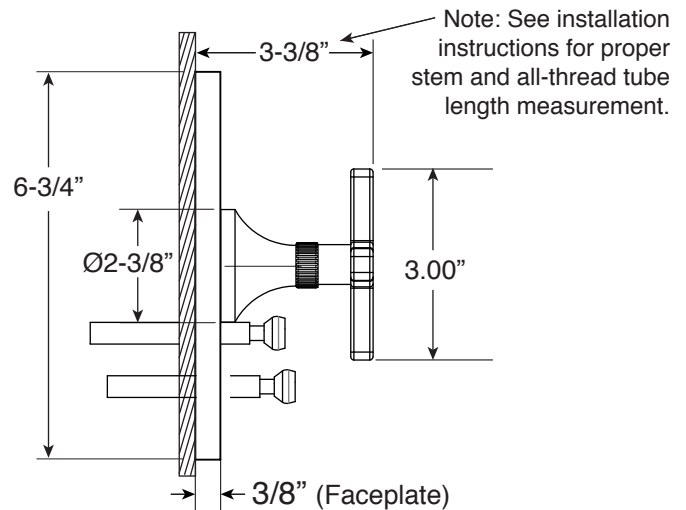
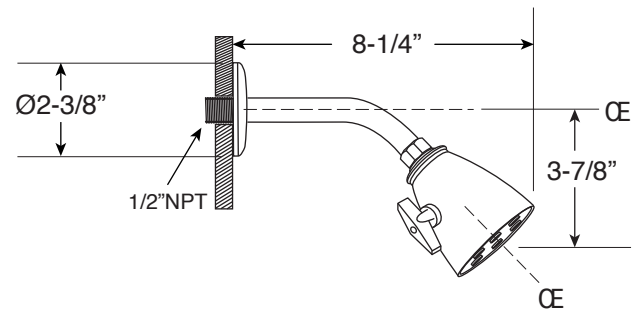

Note: Measurements are subject to change. No responsibility is assumed for use of superseded or voided pages.