

**FEATURES:**

- Solid brass construction
- Valve cartridge: 18.30.893
- Diverter assembly: 18.30.894
- Screwdriver stop: 18.30.895
- Adjustable hot limit safety stop
- Reversible cartridge
- 5.0 GPM @ 60 PSI
- Certified to meet or exceed the following codes and standards:  
ASME A112.18.1/CSAB 125.1-2012

**Series 800/830**  
**Pressure Balance Tub and Shower Set**

1.808168  
(1.808168T - Trim Only)

**Houston Handle**

**16 pt.**

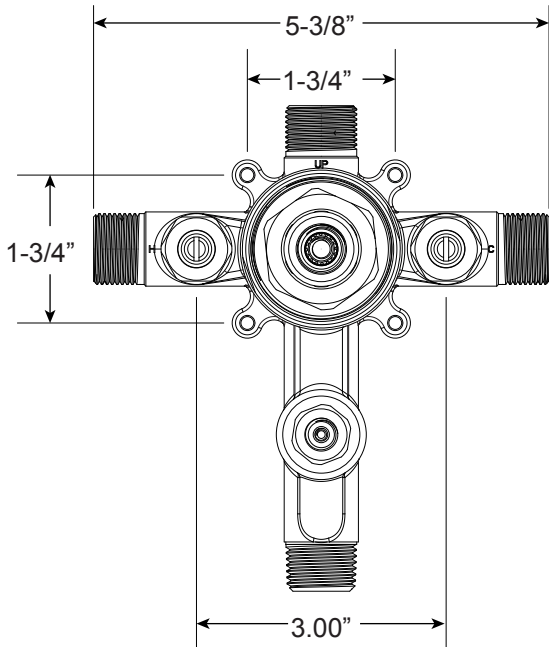

**FRONT VIEW**

*Note: Stem and all-thread tube will be sent with handle trim.*

**SIDE VIEW**

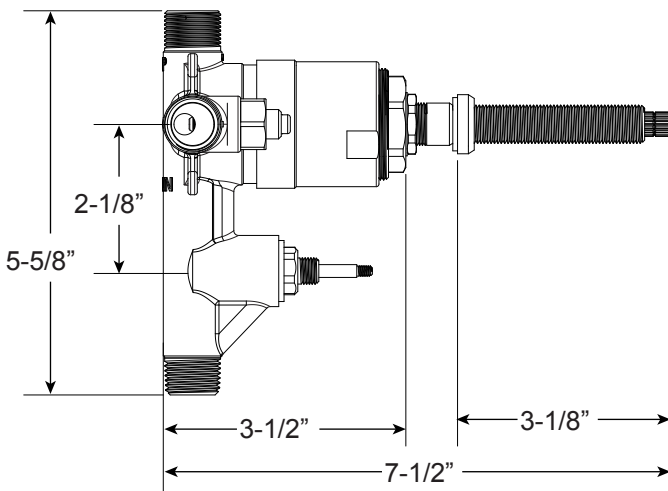

Current valve in use:  
Circa 4/2014 - present  
Contact Customer Service  
for Older Versions

For additional information on  
cartridges or extension kits,  
see 'Rough Valving' section  
in current catalog.

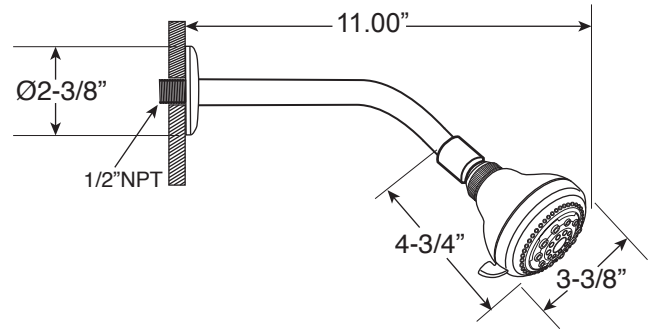

*Note: See installation instructions for proper stem and all-thread tube length measurement.*

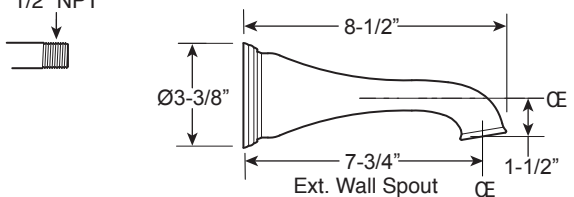
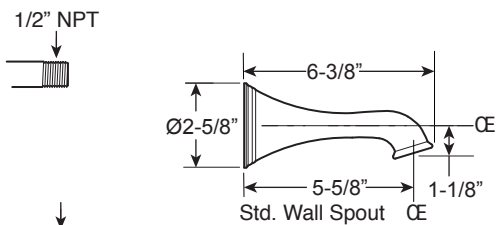
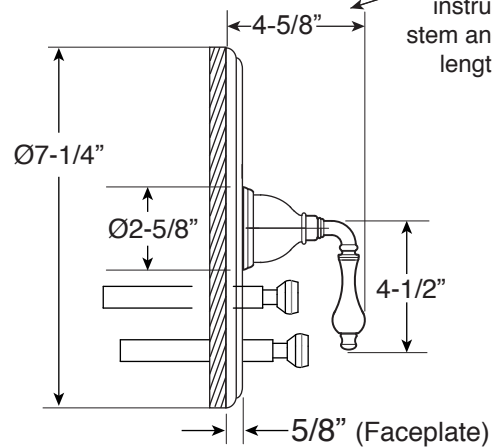

*Note: Measurements are subject to change. No responsibility is assumed for use of superseded or voided pages.*