

Features:

- Forged brass construction
- Ceramic disk valve cartridge 18.30.865
- Adjustable hot limit safety stop
- Reversible cartridge
- Certified to meet or exceed the following codes and standards:  
ASME A112.18.1/CSAB 125.1-2012

## Lira

### Pressure Balance Tub & Shower

### 1.518268

(1.518268T - Trim Only)

Cutaway View

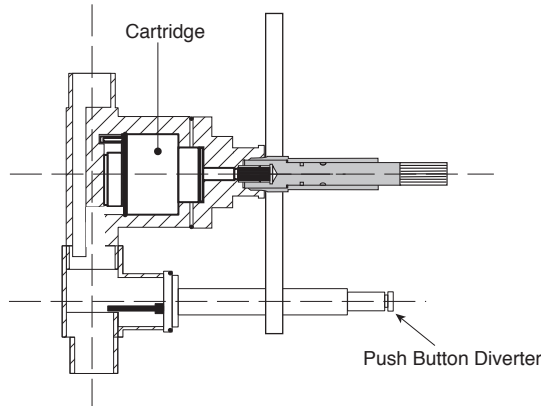

Top View

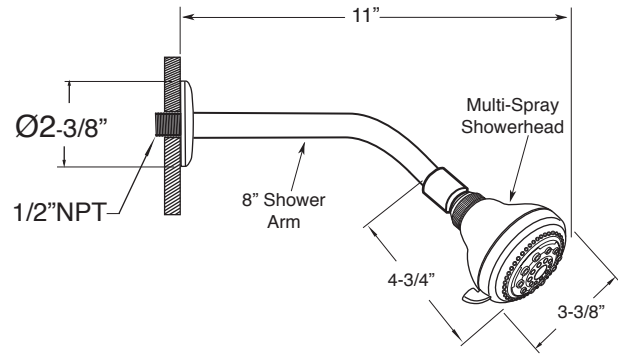
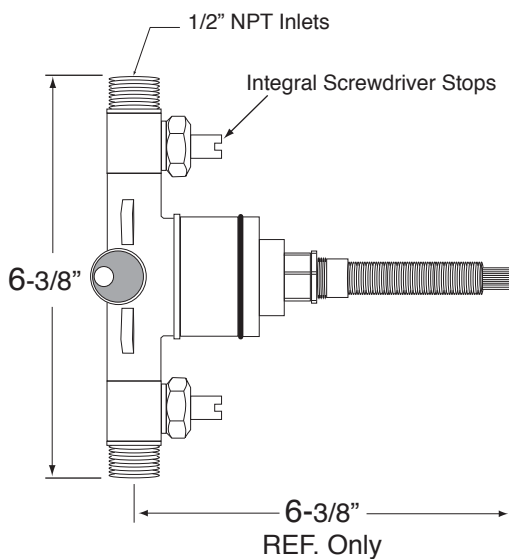

Note: See installation Instructions for length of stem required from finished wall.

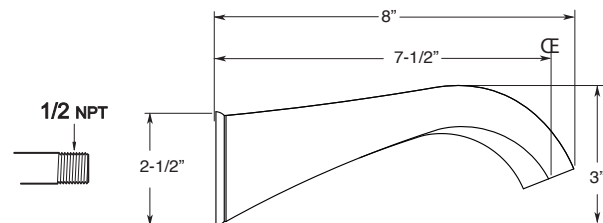
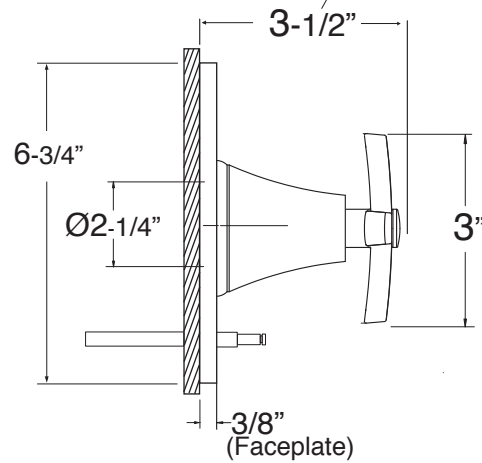

WALL SPOUT  
P/N 18.17.029

Note: Measurements are subject to change or cancellation. No responsibility is assumed for use of superseded or voided pages.