

Stixx

Pressure Balance Tub & Shower

1.239568D

(1.239568DT Trim Only)

Features:

- Forged brass construction
- Ceramic disk valve cartridge 18.30.865
- Adjustable hot limit safety stop
- Reversible cartridge
- Certified to meet or exceed the following codes and standards:
ASME A112.18.1/CSAB 125.1-2011

Cutaway View

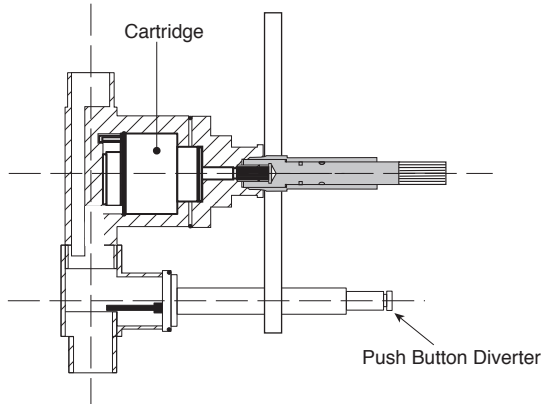

Top View

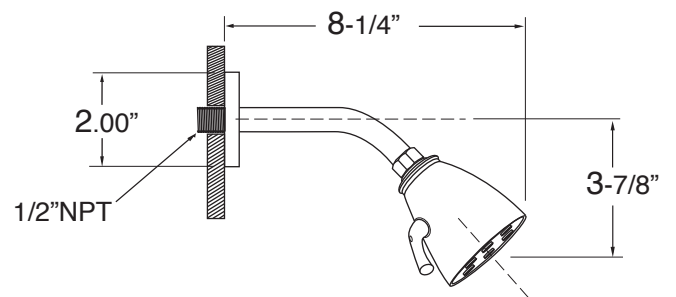
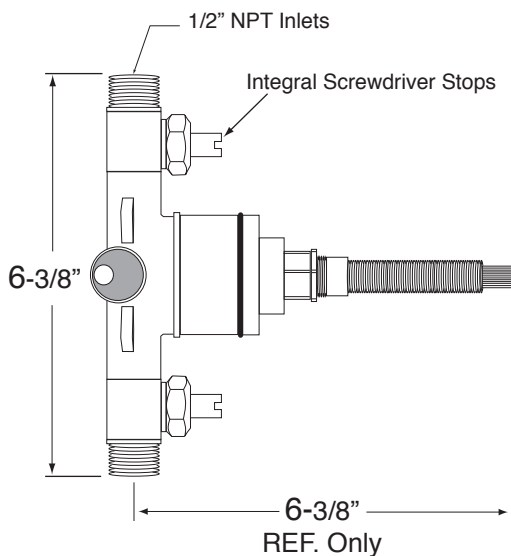

Note: See installation Instructions for length of stem required from finished wall.

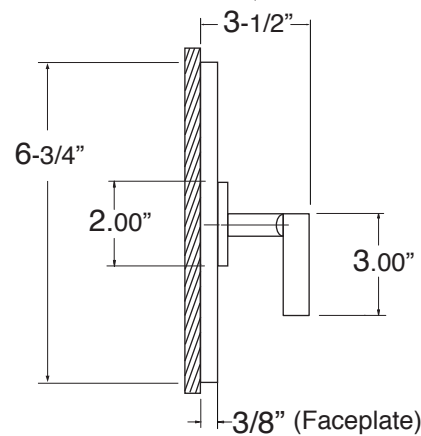

1/2" NPT Quick Connect

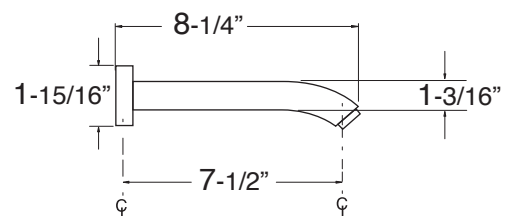

Note: Measurements are subject to change or cancellation. No responsibility is assumed for use of superseded or voided pages.