

Features:

- Forged brass construction
- 8" Center to Center valve (18.30.008)
- 10" Center to Center valve available on request (18.30.141)
- Replacement ceramic disc cartridge:  
COLD 18.30.035 / HOT 18.30.036
- Certified to meet or exceed the following codes and standards:  
ASME A112.18.1/CSAB 125.1-2011

## 2 Valve Shower Set

8" Spread

1.008542

## Chicago Handle

(1.008542T Trim Only)

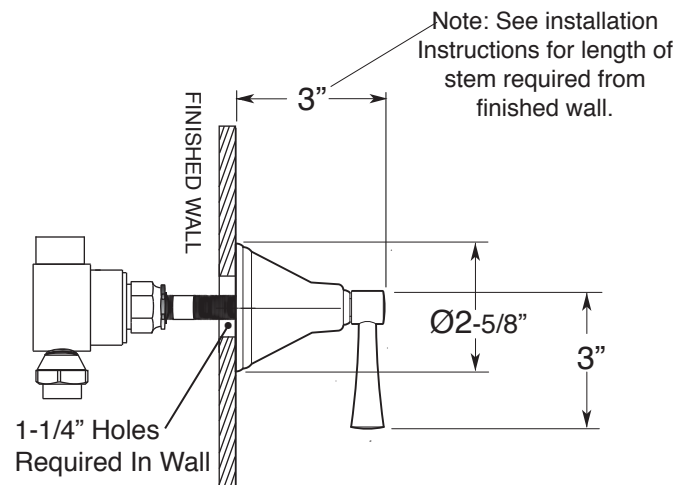
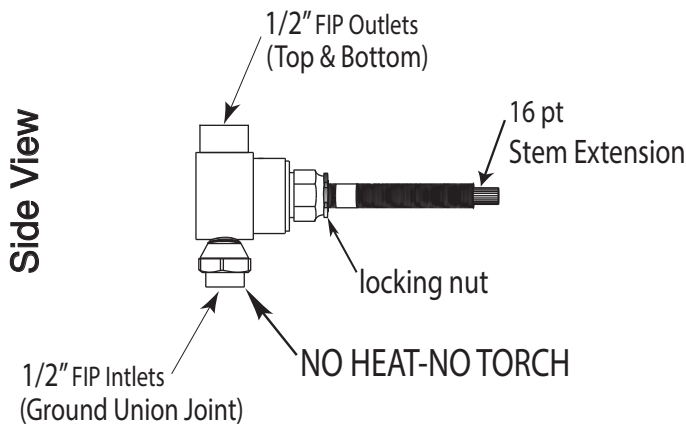
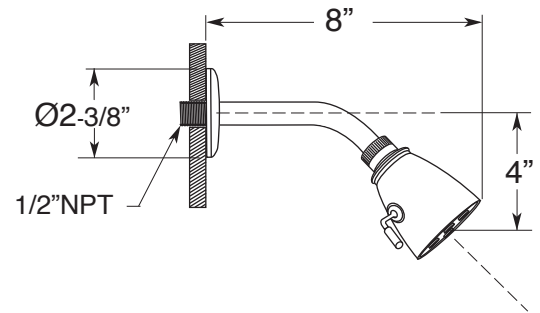
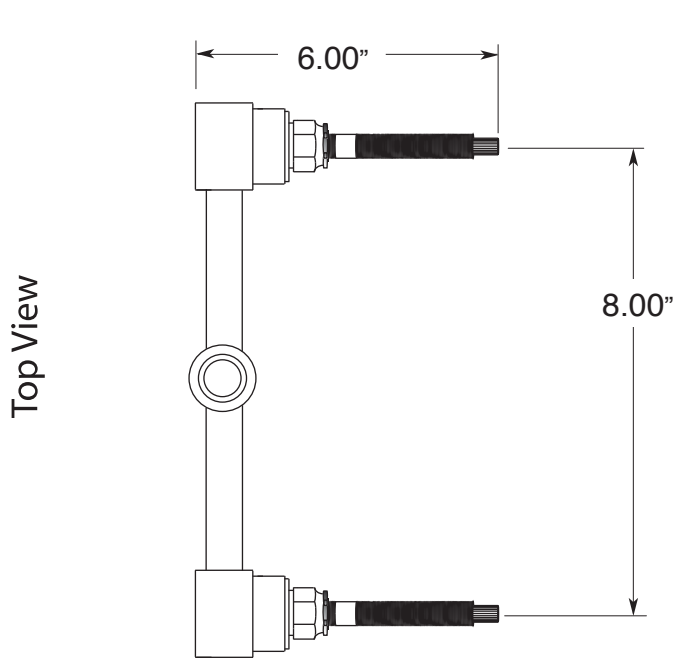

Note: Measurements are subject to change or cancellation. No responsibility is assumed for use of superseded or voided pages.