

Feature

Ductile iron wafer automatic balancing valve
 For ASME B16.42 class 150 flanges
 Provided with eyebolt for DN≥4"
 Wide range of flows available (see cartridge section)
 Test points included

Class 150

Working conditions

Water: 15°F - 260°F

below 32°F only for water with added antifreezing fluids

over 212°F only for water with added anti-boiling fluids

Flow range from 25.4GPM to 127GPM for 2½" and 3" (single cartridge)

Higher flows available with the multi cartridge system for DN≥4"

Minimum working ΔP depending on cartridge configuration



Material

	Part	Material	Specification
1	Body	Ductile Iron	ASTM A536 60-40-18
2	Blind cap	DZR brass	ASTM C35330
3	Screw ¹	Stainless Steel	-
4	Washer ¹	Stainless Steel	-
5	Piston	Stainless Steel	-
6	Cartridge body	DZR brass	ASTM C35330
7	Cartridge spring	Stainless Steel	AISI 302
8	Cartridge O-ring	EPDM Perox	-
9	Eyebolt	Steel	-
10	Extension	DZR brass	ASTM C35330
11	Test point	DZR brass ²	ASTM C35330

¹ For 2½" and 3", Stainless Steel Spring is used instead of Screw and Washer

³ Test points with EPDM gaskets and polypropylene ties

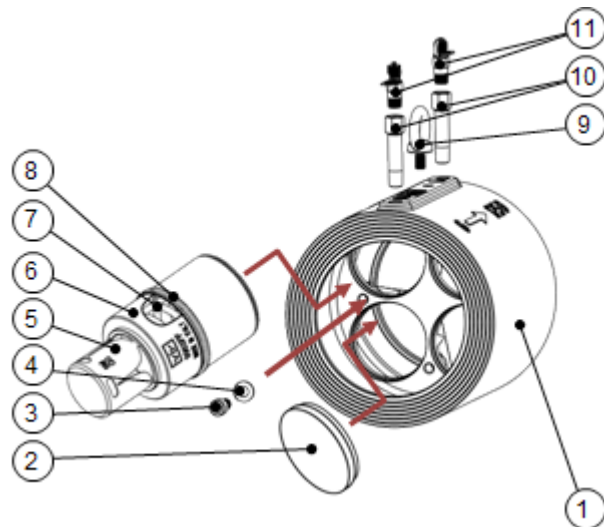

Dimension

Size	ØD	A	H	# of cartridge	Valve Wt. ¹	Cart. Wt. ²	Flow Rate
	[in]	[in]	[in]		[lb]	[lb]	[GPM]
2½"	4.69	6.69	6.38	1	9.0	3.0	25.4-127
3"	5.16	6.69	6.61	1	12.3	3.0	25.4-127
4"	6.42	8.27	7.24	2	18.5	3.0	25.4-254
5"	7.60	8.27	7.83	3	23.4	3.0	25.4-381
6"	8.50	8.27	8.27	4	27.6	3.0	25.4-508
8"	10.7	8.27	9.37	7	34.8	3.0	25.4-889
10"	12.9	8.27	10.5	10	49.2	3.0	25.4-1,270
12"	15.1	8.27	11.6	14	61.1	3.0	25.4-1,778

¹ For valve body without cartridge

³ For single cartridge

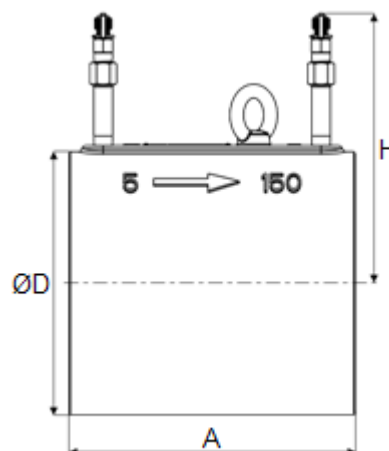

Cartridges

Cartridges are available for different flowrates. The minimum working DP depends on the specific cartridge model (see table below). A numeric code is marked on the cartridge body identifying it (example: model KRR996266.1880).

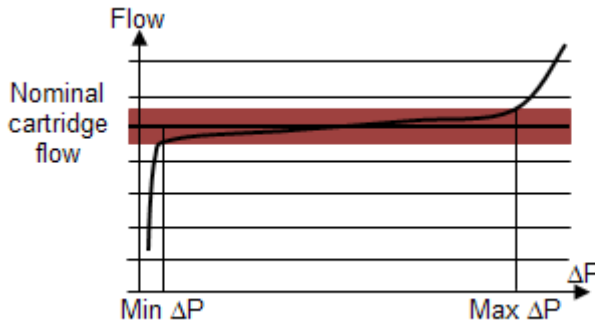

Flow regulation accuracy +/-5% of nominal flow

The test points allow verification of ΔP value to ensure that it is within the operating ΔP Range.

RWV code	Flow Rate [GPM]	ΔP Range [psi]
KRR996216.1880	25.4	2.0-33
KRR996218.1880	28.5	2.0-33
KRR996220.1880	31.7	2.0-33
KRR996222.1880	34.9	2.2-33
KRR996224.1880	38.0	2.2-33
KRR996227.1880	42.8	2.2-33
KRR996230.1880	47.6	2.3-33
KRR996233.1880	52.3	2.3-33
KRR996236.1880	57.1	2.3-33
KRR996240.1880	63.4	2.5-33
KRR996245.1880	71.3	2.5-33
KRR996250.1880	79.3	2.8-33
KRR996255.1880	87.2	2.8-33
KRR996260.1880	95.1	3.0-33
KRR996266.1880	105	3.0-33
KRR996273.1880	116	3.6-33
KRR996280.1880	127	4.1-33

Installation

The valve must be installed with the flow matching the arrow marked on the valve body.

To obtain the best performance:

- Verify system is properly flushed prior to installig the cartridge/cartridges
- Use at least one strainer for each installation
- Ensure water quality is in accordance with DVI 2035

