

DZR Lead Free Brass Full Port EzPress Ball Valve

Feature

- 600# WOG
- DZR lead free brass body
- Full port
- Dual EzPress ends
- Chrome plated ball
- PTFE seats
- Blow-out proof stem
- Adjustable packing
- MSS-SP-110
- AB1953, NSF/ANSI 61 & 372 certified

Meet BAA requirement



| Pressure/ Temperature rating | |
|------------------------------|------------------------|
| Valve body and stem | |
| 600 psi from 15 °F to 160 °F | 150 psi max. at 366 °F |
| Press connections | |
| 250 psi from 15 °F to 160 °F | 150 psi max. at 250 °F |

Material

| | Part | Material | Specification |
|----|--------------|-----------------------------|------------------|
| 1 | Body | DZR Lead Free Brass | ASTM B927 C27453 |
| 2 | End piece | DZR Lead Free Brass | ASTM B927 C27453 |
| 3 | Ball | Lead Free Brass / Cr plated | ASTM B927 C28500 |
| 4 | Seat | PTFE | PTFE |
| 5 | Stem | Lead Free Brass | ASTM B927 C28500 |
| 6 | Packing ring | PTFE | PTFE |
| 7 | Packing nut | Brass | ASTM B124 C37700 |
| 8 | Handle | Steel / Geomet® plated | A36 |
| 9 | Nut | Steel / Zn plated | A36 |
| 10 | Valve info | - | - |
| 11 | O-ring | EPDM Perox | NSF approved |

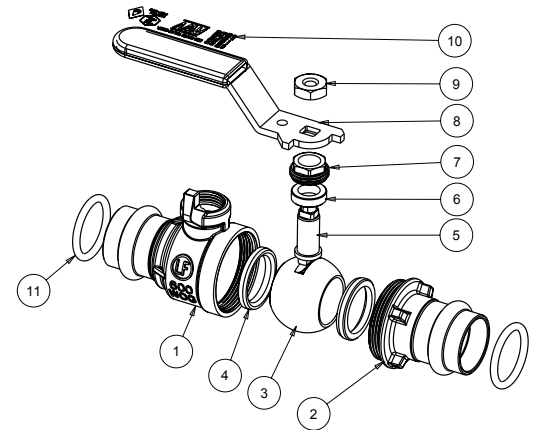

Dimension, Cv, Weight

| Size | A [in] | L [in] | H [in] | D [in] | P [in] | C [in] | Cv | Wt. [lb] |
|--------|--------|--------|--------|--------|--------|--------|-----|----------|
| 1/2" | 2.93 | 3.60 | 2.13 | 0.64 | 0.59 | 0.86 | 15 | 0.48 |
| 3/4" | 3.54 | 3.60 | 2.26 | 0.89 | 0.79 | 0.98 | 30 | 0.70 |
| 1" | 3.90 | 4.98 | 2.58 | 1.14 | 0.98 | 1.06 | 60 | 1.26 |
| 1 1/4" | 4.29 | 4.98 | 2.82 | 1.39 | 1.26 | 1.06 | 110 | 1.64 |
| 1 1/2" | 5.24 | 5.57 | 3.29 | 1.64 | 1.57 | 1.26 | 130 | 2.54 |
| 2" | 6.18 | 5.57 | 3.58 | 2.14 | 1.97 | 1.46 | 360 | 3.74 |

