

5

4

3

2

1

C

C

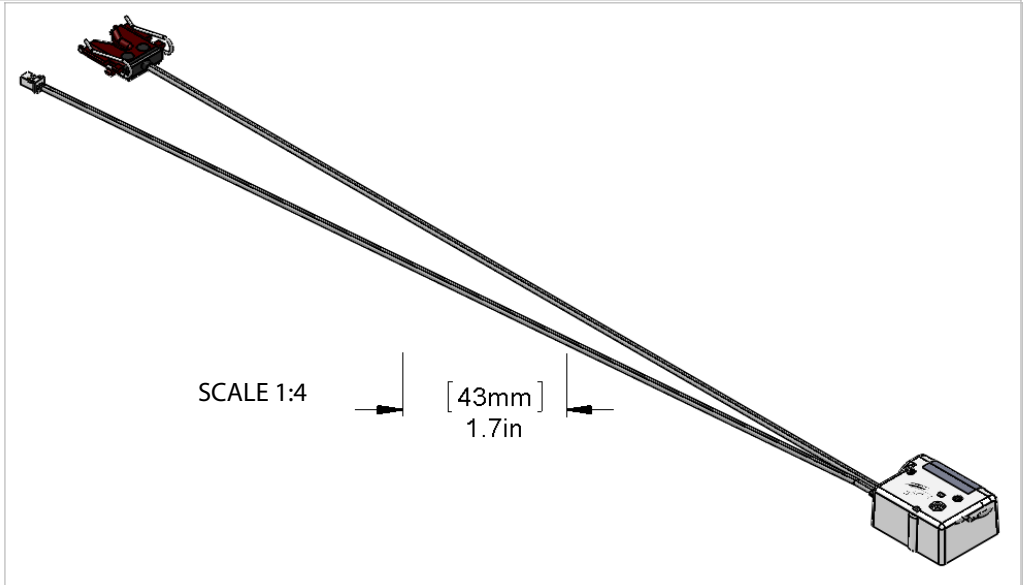
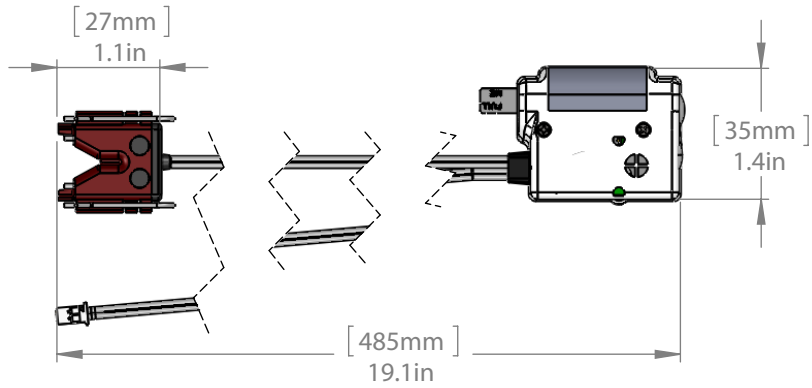

B

B

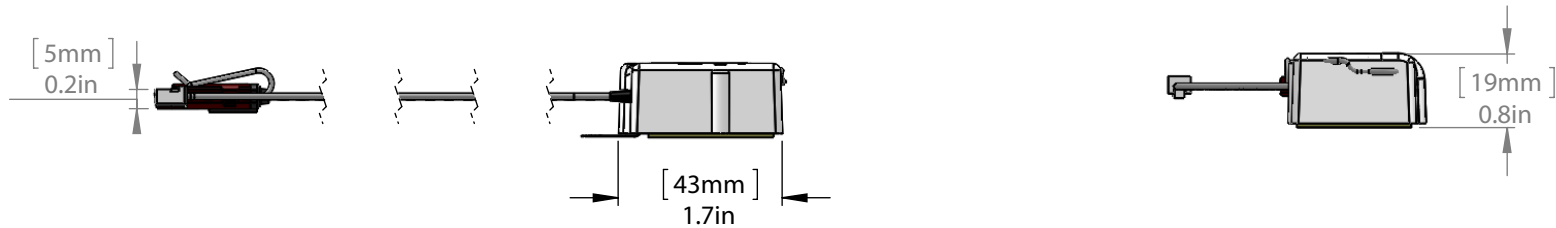

NOTES:
CONTAINS A 3V LITHIUM BATTERY
PLEASE DISPOSE OF PROPERLY

ENGINEERING	NAME	DATE
DRAWN BY ENG.	DS	2/22/12
CHECKED BY ENG.	JK	2/22/12
ENG APPR.	CC	2/22/12
MFG APPR.	CC	2/22/12



2601 Spenwick Drive,
Houston, TX 77055
800-231-3345

UNLESS OTHERWISE SPECIFIED:

PROPRIETARY AND CONFIDENTIAL

DIMENSIONS ARE IN INCHES
TOLERANCES:
FRACTIONAL ±.032
ANGULAR: MACH ±.5° BEND ±2°
TWO PLACE DECIMAL ±.010
THREE PLACE DECIMAL ±.005

INTERPRET GEOMETRIC
TOLERANCING PER: ANS1 Y14.5, 1994

THE INFORMATION CONTAINED IN THIS
DRAWING IS THE SOLE PROPERTY OF
RECTORSEAL.
ANY REPRODUCTION IN PART OR AS A
WHOLE WITHOUT THE WRITTEN
PERMISSION OF RECTORSEAL IS
PROHIBITED.

TITLE:

AG-9300-MIT SPECIFICATION SHEET

SIZE
A

SCALE: 1:2

SHEET 1 OF 1

5

4

3

2

1

A