



Automatic Circulating Tank Water Heater (*Chauffe-eau à circulation automatique*)

Hybrid Tank-Tankless Water Heater

Operation and Installation Manual

RH180 (REU-VA1320WF-US)

FOR INDOOR APPLICATIONS ONLY

ANSI Z21.10.3 • CSA 4.3-(2011)



This entire manual must be left for the consumer. The consumer must read and refer to this manual for proper operation and to maintain the water heater.

READ ALL OF THE INSTRUCTIONS THOROUGHLY BEFORE INSTALLING OR OPERATING THIS WATER HEATER.

This manual provides information on the installation, operation, and maintenance of the water heater. For proper operation and **safety**, it is important to follow the instructions and adhere to the safety precautions.

A licensed professional must install the water heater according to the exact instructions on pages 4-30.

The consumer must read the entire manual to properly operate the water heater and to have regular maintenance performed.

⚠ WARNING

If the information in these instructions is not followed exactly, a fire or explosion may result causing property damage, personal injury or death.

- Do not store or use gasoline or other flammable vapors and liquids in the vicinity of this or any other appliance.
- **WHAT TO DO IF YOU SMELL GAS**
 - Do not try to light any appliance.
 - Do not touch any electrical switch; do not use any phone in your building.
 - Immediately call your gas supplier from a neighbor's phone. Follow the gas supplier's instructions.
 - If you cannot reach your gas supplier, call the fire department.
- Installation and service must be performed by a licensed professional.

⚠ AVERTISSEMENT

Assurez-vous de bien suivre les instructions données dans cette notice pour réduire au minimum le risque d'incendie ou d'explosion ou pour éviter tout dommage matériel, toute blessure ou la mort.

- Ne pas entreposer ni utiliser d'essence ou ni d'autres vapeurs ou liquids inflammables à proximité de cet appareil ou de tout autre appareil.
- **QUE FAIRE SI VOUS SENTEZ UNE ODEUR DE GAZ :**
 - Ne pas tenter d'allumer d'appareil.
 - Ne touchez à aucun interrupteur ; ne pas vous servir des téléphones se trouvant dans le bâtiment.
 - Appelez immédiatement votre fournisseur de gaz depuis un voisin. Suivez les instructions du fournisseur.
 - Si vous ne pouvez rejoindre le fournisseur, appelez le service des incendies.
- L'installation et l'entretien doivent être assurés par un installateur ou un service d'entretien qualifié ou par le fournisseur

Table of Contents

Safety Definitions	2	Checklist for Gas and Electricity	26
Safety Behaviors and Practices for the Consumer and Installer	3-5	Final Checklist	27
Installation Instructions		Technical Data	
Installer Qualifications	6	Specifications	28
General Instructions.....	6	Dimensions	29
Determine Installation Location.....	8	Wire Diagram.....	30
Installation Location.....	9	Parts Breakdown.....	31
Checklist to Determine Location.....	10	Operation	
Minimum Clearances	11	Consumer Operation Guidelines for the Safe Operation of your Water Heater	32
Typical Installation Illustration.....	12	How to use the Temperature Controller	33
Combustion Air Requirements.....	13-15	Diagnostic Codes and Remedies	35-36
Venting Requirements	16-19	Required Maintenance	
Checklist for Combustion Air and Venting	20	Air Screen.....	37
Installation of Plumbing	21	Water Filter.....	38
Checklist for Plumbing	22	Required Maintenance	39-40
Massachusetts-Required Plumbing	23	Consumer Support	
Installation of Gas Supply.....	24-25	Warranty Registration Information	41
Connect Electricity	26	Limited Warranty.....	41-43
Adjust for High Altitude	26		

NOTICE: Rinnai sometimes shares customer contact information with businesses that we believe provide products or services that may be useful to you. By providing this information, you agree that we can share your contact information for this purpose. If you prefer not to have your information shared with these businesses, please contact customer service and ask not to have your information shared. We will however, continue to contact you with information relevant to the product(s) you registered and/or you account with us.

If you have any questions or feel that the manual is incomplete contact Rinnai at 1-800-621-9419.

Safety Definitions



This is the safety alert symbol. This symbol alerts you to potential hazards that can kill or hurt you and others.



Indicates an imminently hazardous situation which, if not avoided, will result in death or serious injury.



Indicates a potentially hazardous situation which, if not avoided, could result in death or serious injury.



Indicates a potentially hazardous situation which, if not avoided, could result in minor or moderate injury. It may also be used to alert against unsafe practices.

Safety Behaviors and Practices for the Consumer and Installer

WARNING

- Before operating, smell all around the appliance area for gas. Be sure to smell next to the floor because some gas is heavier than air and will settle on the floor.
- Keep the area around the appliance clear and free from combustible materials, gasoline, and other flammable vapors and liquids.
- Combustible construction refers to adjacent walls and ceiling and should not be confused with combustible or flammable products and materials. Combustible and/or flammable products and materials should never be stored in the vicinity of this or any gas appliance.
- Always check the water temperature before entering a shower or bath.
- To protect yourself from harm, before performing maintenance:
 - ◇ Turn off the electrical power supply by unplugging the power cord or by turning off the electricity at the circuit breaker. (The temperature controller does not control the electrical power.)
 - ◇ Turn off the gas at the manual gas valve, usually located adjacent to the water heater.
 - ◇ Turn off the incoming water supply. This can be done at the cold water supply valve immediately below the water heater or by turning off the water supply to the building.
- Caution: Label all wires prior to disconnection when servicing controls. Wiring errors can cause improper and dangerous operation.
(Attention: Au moment de l'entretien des commandes, étiquetez tous les fils avant de les débrancher. Des erreurs de câblage pouvant entraîner un fonctionnement inadéquate et dangereux.)
- Verify proper operation after servicing.
(S'assurer que l'appareil fonctionne adéquate une fois l'entretien terminé.)
- Use only your hand to push in or turn the gas control knob. Never use tools. If the knob will not push in or turn by hand, do not try to repair it; call a licensed professional. Force or attempted repair may result in a fire or explosion.
- Do not use this appliance if any part has been under water. Immediately call a qualified service technician to inspect the appliance and to replace any part of the control system and any gas control which has been under water.
(N'utilisez cet appareil si l'alimentation a été plongée dans l'eau, même partiellement. Faites inspecter l'appareil par un technicien qualifié et remplacez toute partie du système de contrôle et toute commande qui ont été plongés dans l'eau.)
- Do not use substitute parts that are not authorized for this appliance.
- Should overheating occur or the gas supply fail to shut off, turn off the manual gas control valve to the appliance.
(En cas de surchauffe ou si l'alimentation en gaz ne s'arrête pas, fermez manuellement le robinet d'arrêt de l'admission de gaz.)
- Do not adjust the DIP switch unless specifically instructed to do so.
- Do not use an extension cord or an adapter plug with this appliance.
- Any alteration to the appliance or its controls can be dangerous and will void the warranty.
- Make sure the water heater and its water lines are protected from freezing. Damage due to freezing is not covered by the warranty.
- Suitable for combination water (potable) heating and space heating and not suitable for space heating applications only.
(Convient au chauffage combiné de l'eau (potable) et des locaux, mais non au chauffage des locaux seulement.)
- This appliance must be installed in accordance with local codes, the National Fuel Gas Code, ANSI Z223.1 / NFPA 54 or the CSA B149.1, Natural Gas and Propane Installation Code.
(Cet appareil doit être installé selon les règlements locaux, ou en l'absence de tels règlements, selon le National Fuel Gas Code, ANSI Z223.1/NFPA 54, ou les, Code d'installation du gaz naturel et du propane, CSA-B149.1.)
- **WARNING**—Follow instructions for proper installation.
(AVERTISSEMENT—Suivre les instructions pour une installation appropriée.)

Safety Behaviors and Practices for the Consumer and Installer

CAUTION

- BURN HAZARD. Hot exhaust and vent may cause serious burns. Keep away from water heater unit. Keep small children and animals away from unit.
- Hot water outlet pipes leaving the unit can be hot to touch. In residential applications, insulation must be used for hot water pipes below 36" due to burn risk to children.

California law requires this notice to be provided:

California Proposition 65 lists chemical substances known to the state to cause cancer, birth defects, death, serious illness or other reproductive harm. This product may contain such substances, be their origin from fuel combustion (gas, oil) or components of the product itself.

CAUTION

Hotter water increases the risk of scald injury. Before changing temperature setting, see instruction manual.

ATTENTION

De l'eau plus chaude augmente le risqué de brûlure. Voir la notice d'instructions avant de modifier le réglage de la temperature.

DANGER



Hot water can be dangerous, especially for infants or children, the elderly, or infirm. There is hot water scald potential if the thermostat is set too high.

Water temperatures over 125° F (51° C) can cause severe burns or scalding resulting in death.

Hot water can cause first degree burns with exposure for as little as:

3 seconds at 140° F (60° C)

20 seconds at 130° F (54° C)

8 minutes at 120° F (48° C)

Test the temperature of the water before placing a child in the bath or shower.

WARNING

AVERTISSEMENT

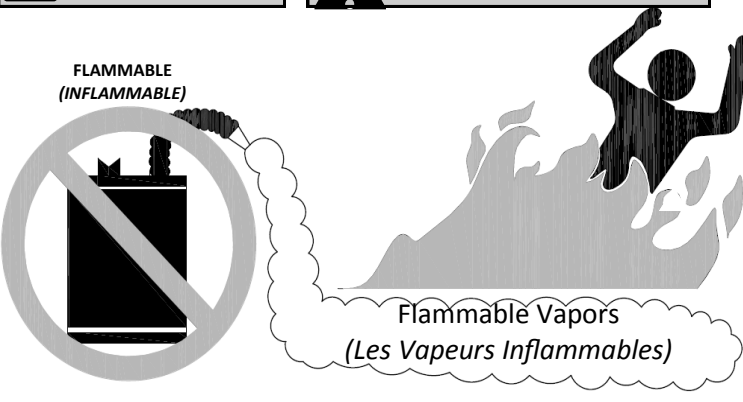

FOR YOUR SAFETY
Do not store or use gasoline or other flammable vapors and liquids in the vicinity of this or any other appliance

POUR VOTRE SECURITE
Ne pas entreposer ni utiliser d'essence ni d'autres vapeurs ou liquids inflammables à proximité de cet appareil ou de tout autre appareil.

Safety Behaviors and Practices for the Consumer and Installer

WARNING

- Do not use this appliance if any part has been under water. Immediately call a qualified service technician to inspect the appliance and to replace any part of the control system and any gas control which has been under water.
(N'utilisez cet appareil s'il alimentation a été plonge dans l'eau, meme partiellement. Faites inspecter l'appareil par un technicien qualifié et remplacez toute partie du système de contrôle et toute commande qui ont été plongés dans l'eau.)
- Any alteration to the appliance or its controls can be dangerous and will void the warranty.
- This appliance is equipped with a three-prong plug for your protection against shock hazard and should be plugged directly into a properly grounded three-prong receptacle. Do not cut or remove the ground prong from this plug.

FVIR (Flammable Vapor Ignition Resistant) Sensor

Flammable liquids such as cleaning solvents, aerosols, paint thinners, adhesives, gasoline and propane must be handled and stored with extreme care. These flammable liquids emit flammable vapors and when exposed to an ignition source can result in a fire hazard or explosion. Flammable liquids should not be used or stored in the vicinity of this or any other appliance.

This water heater is equipped with a flammable vapor sensor and meets the requirements of ANSI Z21.10.1 If flammable vapors are detected, the flammable vapor sensor will close the gas supply to the water heater, the ignition source will be disabled and an "FE" error code will flash on the controller. If the controller is flashing an "FE" or if flammable vapors are suspected:

- Leave the area immediately, leaving the exit point open to allow ventilation
- Do not touch any electric device (including phone or light switch)
- Call emergency personnel from a neighbors phone
- Do not try to reset the water heater or light the pilot to any other appliance

When safety personnel has identified the area as safe and all flammable vapors have been removed and eliminated from the area, the units can be reset by unplugging the unit then plugging back in.

WARNING

Do not spray or use chemicals containing bleach, cleaners, polish, silicone, phosphorous, or lubricants near the water heater. These chemicals will damage the flammable vapor sensor. Never clean or tamper with the flammable vapor sensor. Do not place cat litter near the appliance as it can corrode or damage the sensor. If the sensor is corroded or damaged its reaction time can be affected and it may not react as described.

WARNING

Carbon Monoxide Hazard

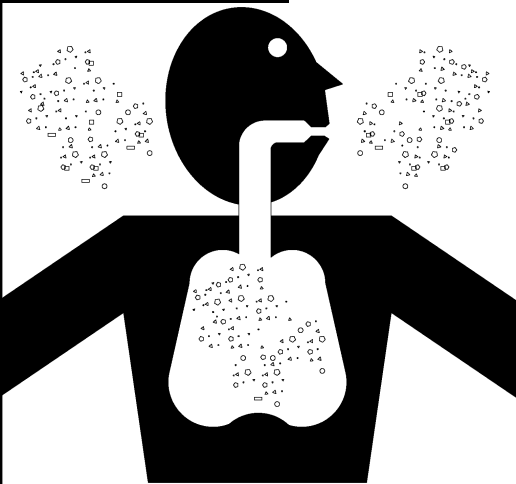

Install vent system per local and national codes.

Read and follow all instructions in this section.

Do not install this water heater above 5,400 ft (1646 m).

Do not obstruct water heater air intake.

Do not operate water heater if flood damaged.

Failure to properly vent this appliance can result in death, personal injury and/or property damage.

Every home should have a carbon monoxide (CO) alarm in the hallway near bedrooms in each sleeping area. Check batteries monthly and replace them annually.

Installation Instructions

Installer Qualifications

A licensed professional must install the appliance, inspect it, and leak test it before use. The warranty will be voided due to improper installation.

The installer should have skills such as:

- gas sizing
- connecting gas lines, water lines, valves, and electricity
- knowledge of applicable national, state, and local codes
- installing venting through a wall or roof
- Venting Category I, Fan Assist Appliances per NFPA54 and local codes

If you lack these skills contact a licensed professional.

Installation Steps

Determine Installation Location	8
Installation Location	9
Checklist to Determine Location	10
Minimum Clearances.....	11
Typical Installation Illustration	12
Combustion Air Requirements	13-15
Venting Requirements	16-19
Checklist for Combustion Air and Venting	20
Installation of Plumbing.....	21
Checklist for Plumbing	22
Massachusetts-Required Plumbing	23
Installation of Gas Supply	24-25
Connect Electricity.....	26
Adjust for High Altitude	26
Checklist for Gas and Electricity	26
Final Checklist	27

General Instructions

DO NOT

- Do not install the RH180 outdoors.
- Do not install the appliance in an area where water leakage of the unit or connections will result in damage to the area adjacent to the appliance or to lower floors of the structure. When such locations cannot be avoided, it is recommended that a suitable drain pan, adequately drained, be installed under the appliance. The pan must not restrict combustion air flow.
- Do not obstruct the flow of combustion and ventilation air.
- Do not use this appliance in an application such as a pool or spa heater that uses chemically treated water . (This appliance is suitable for filling large or whirlpool spa tubs with potable water.)
- Do not use substitute parts that are not authorized for this appliance.

MUST DO

- The installation must conform with local codes or, in the absence of local codes, with the *National Fuel Gas Code, ANSI Z223.1/NFPA 54*, or the *Natural Gas and Propane Installation Code, CSA B149.1*.
- The appliance, when installed, must be electrically grounded in accordance with local codes or, in the absence of local codes, with the *National Electrical Code, ANSI/NFPA 70*, or the *Canadian Electrical Code, CSA C22.1*.
- The appliance and its appliance main gas valve must be disconnected from the gas supply piping system during any pressure testing of that system at test pressures in excess of 1/2 psi (3.5 kPa) (13.84 in W.C.).
- The appliance must be isolated from the gas supply piping system by closing its individual manual shutoff valve during any pressure testing of the gas supply piping system at test pressures equal to or less than 1/2 psi (3.5 kPa) (13.84 in W.C.).

- Make sure the water heater and its water lines are protected from freezing. Damage due to freezing is not covered by the warranty.
- You must follow the installation instructions and those in *Care and Maintenance* for adequate combustion air intake and exhaust.
- Install the vacuum relief valve per local codes.
- Massachusetts 248 CMR Section 10.14 (I) "All potable water pressure tanks shall be provided with a vacuum relief valve at the top of the tank that will operate up to a maximum water pressure of 200 P.S.I.G. and to a maximum water temperature of 200°F."

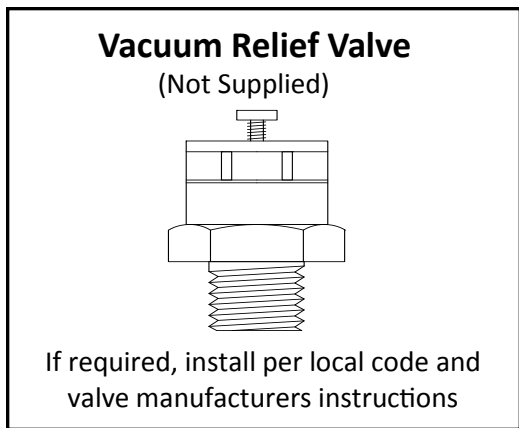

INFORMATION

- If a water heater is installed in a closed water supply system, such as one having a backflow preventer in the cold water supply line, means shall be provided to control thermal expansion. Contact the water supplier or local plumbing inspector on how to control thermal expansion.
- Should overheating occur or the gas supply fail to shut off, turn off the manual gas control valve to the appliance.
- Keep the air intake location free of chemicals such as chlorine or bleach that produce fumes. These fumes can damage components and reduce the life of your appliance.

Prepare for installation

Parts included

- Water heater
- Temperature-Pressure Relief (T&P) Valve
- Gas Valve

Tools needed

- Manometer
- Pipe wrenches (2)
- Adjustable pliers
- Screwdrivers (2)
- Wire cutters
- Gloves
- Safety glasses
- Level

Tools that might be needed

- Saw
- Threading machine with heads and oiler
- Torch set
- Copper tubing cutter
- Steel pipe cutter

Materials needed

- Soap solution
- Approved venting
- Teflon tape (recommended) or pipe compound

Materials that may be needed

- Heat tape
- Pipe insulation
- Electrical wire and conduit per local code
- Single gang electrical box
- Wire nuts
- Unions and drain valves

Determine Installation Location

You must ensure that clearances will be met and that the vent length will be within required limits. Consider the installation environment, water quality, and need for freeze protection. Requirements for the gas line, water lines, and electrical connection can be found in their respective installation sections of this manual.

Water Quality

Consideration of care for your water heater should include evaluation of water quality.

Water that contains chemicals exceeding the levels below affect and damage the heat exchanger. Replacement of the heat exchanger due to water quality damage is not covered by the warranty.

	Maximum Level
Total Hardness	Up to 200 mg / L
Aluminum *	Up to 0.2 mg / L
Chlorides *	Up to 250 mg / L
Copper *	Up to 1.0 mg / L
Iron *	Up to 0.3 mg / L
Manganese *	Up to 0.05 mg / L
pH *	6.5 to 8.5
TDS (Total Dissolved Solids) *	Up to 500 mg / L
Zinc *	Up to 5 mg / L

* Source: Part 143 National Secondary Drinking Water Regulations

If you install this water heater in an area that is known to have hard water or that causes scale build-up the water must be treated and/or the heat exchanger flushed regularly.

Environment

Air surrounding the water heater is used for combustion and must be free of any compounds that cause corrosion of internal components. These include corrosive compounds that are found in aerosol sprays, detergents, bleaches, cleaning solvents, oil based paints/ varnishes, and refrigerants. The air in beauty shops, dry cleaning stores, photo processing labs, and storage areas for pool supplies often contains these compounds. Therefore it is recommended that such locations be avoided.

If it is necessary for a water heater to be located in areas which may contain corrosive compounds, the following instructions are strongly recommended.

IMPORTANT CONSIDERATIONS FOR INSTALLATION:

- DO NOT Install in areas where air for combustion can be contaminated with chemicals.
- Before installation, consider where air has the ability to travel within the building to the water heater.
- Chemicals that are corrosive in nature should not be stored or used near the water heater.

Damage and repair due to corrosive compounds in the air is not covered by warranty.

Location

This water heater is not approved for use in manufactured (mobile) homes or outdoor installations.

Attic:

Installation of the water heater must be accomplished in such a manner that if the tank or any connection should leak, the flow of water will not cause damage to the structure. For this reason, it is not advisable to install the water heater in an attic or upper floor. When such locations cannot be avoided, a suitable drain pan should be installed under the water heater. (See drain pan below)

Garage:

Although this water heater is equipped with a flammable vapor sensor, gasoline and other flammable substances should not be stored or used in the same vicinity or area of the water heater or any other appliance that may produce a spark or open flame.

It is not required to position this water heater on a stand as this water heater complies with the FVIR requirements and the burner and igniter are positioned greater than 18 inches from the base of the unit.

This water heater must be positioned or located as to not be subject to damage by a moving vehicle.

Refer to local code for installation requirements in a garage.

Crawl Space:

When installing this water heater in a crawl space with a dirt floor, position the water heater on a solid concrete platform, or base to avoid damage to the unit. (Do not use wood)

Drain Pan: If the water heater is installed in a location that could result in damage to the home or structure precautions must be taken to protect the property from water damage. In the event of a tank or component failure, an appropriately sized pan must be installed under the water heater. The pan must drain with a minimum diameter $\frac{3}{4}$ " connection and shall be drained per local code requirements.

Stand: Depending on local code, a stand may not be required due to the ignition source being over 18" from the base of the appliance.

Alcove or closet:

See clearance requirements and combustion air requirements.

Insulation Blanket:

This water heater meets or exceeds the National Appliance Energy Conservation Act standards with respect to insulation and standby losses. If an insulation blanket is still desired, the following procedure must be followed.

- a. Maintain an adequate distance from the vent.
- b. Do not cover the front door of the tankless engine or the lower enclosure of the assembly.
- c. Do not cover the combustion air grill located on the front door of the tankless engine.
- d. Do not obstruct the operation of the pressure relief valve.
- e. Obtain new warning labels from the manufacturer to place on the blanket, directly over the existing labels.
- f. Frequently inspect the blanket to ensure the insulation blanket has not been disturbed.

Checklist to Determine Installation Location

- The water heater is not exposed to corrosive compounds in the air.
- The water heater location complies with the clearances stated in the manual and on the label, located on the side of the unit.
- The area surrounding the water heater does not contain flammable vapors that could ignite.
- The water supply does not contain chemicals or exceed total hardness that will damage the heat exchanger.
- The water heater and its water lines are protected from freezing.
- A standard 3 prong 120 VAC, 60 Hz properly grounded wall outlet or other properly grounded 120 VAC, 60 Hz source is available.
- The installation must conform with local codes or, in the absence of local codes, with the *National Fuel Gas Code, ANSI Z223.1/NFPA 54*, or the *Natural Gas and Propane Installation Code, CSA B149.1*.
- Leave the entire manual taped to the water heater or give the entire manual directly to the consumer.**

Minimum Clearances

The minimum clearances from combustibles or non-combustibles construction, 0 inches from the sides, 0 inches from the back, and 12 inches from the top.

For closet installation, 4 inches front, or for alcove installation

(Dégagements minimaux à assurer entre les parois de l'appareil et les constructions incombustibles: 0 po (côtés), 0 po (arrière) et 12 po (dessus).)

(Installation dans une garde-robe: assurer un dégagement de 4 po devant l'appareil. Pour installation dans une alcôve.)

Clearance to be in accordance with local installation codes and the requirements of the gas supplier.

(Dégagement conforme aux codes d'installation locaux et aux exigences due fournisseur de gaz.)

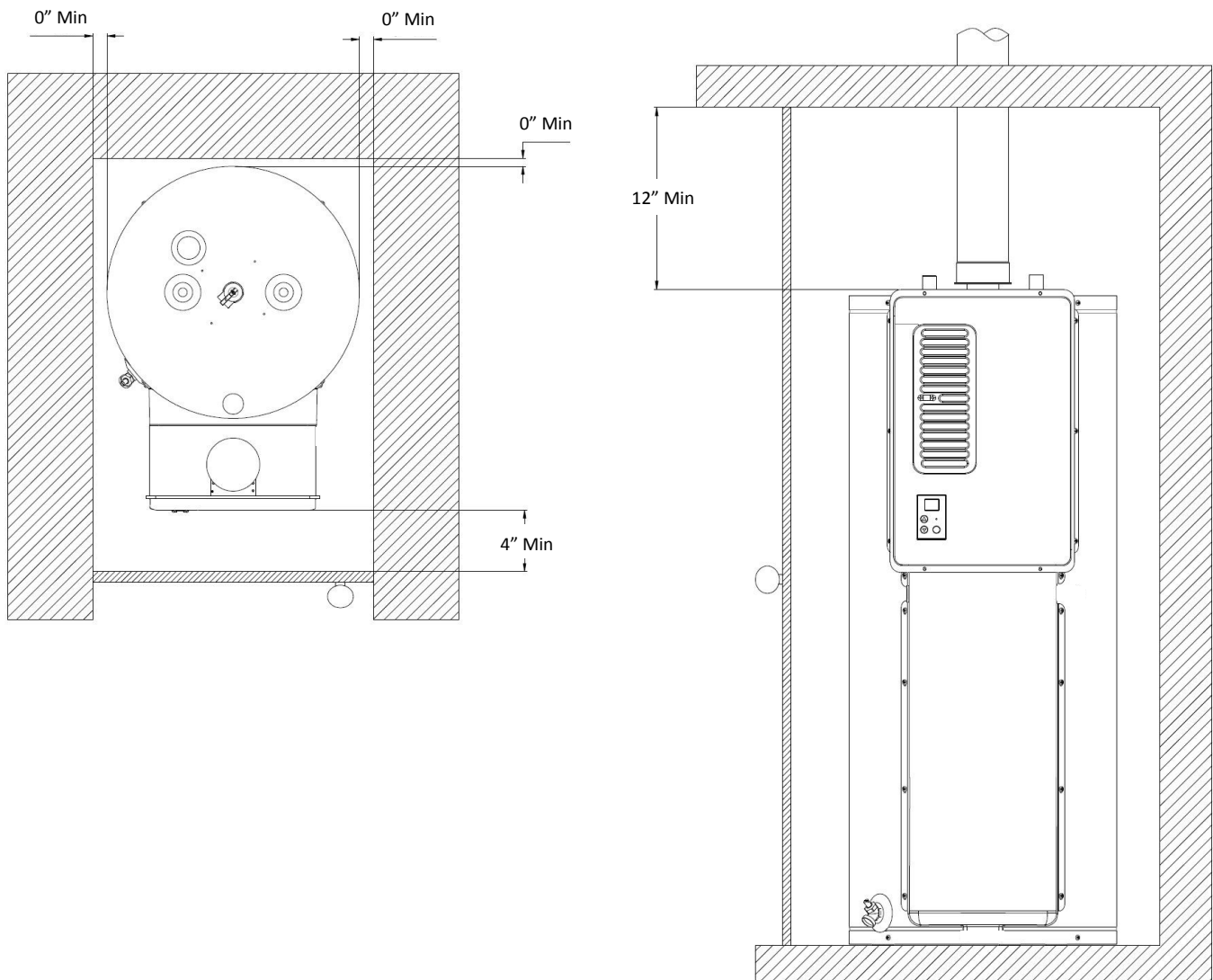

Typical Installations

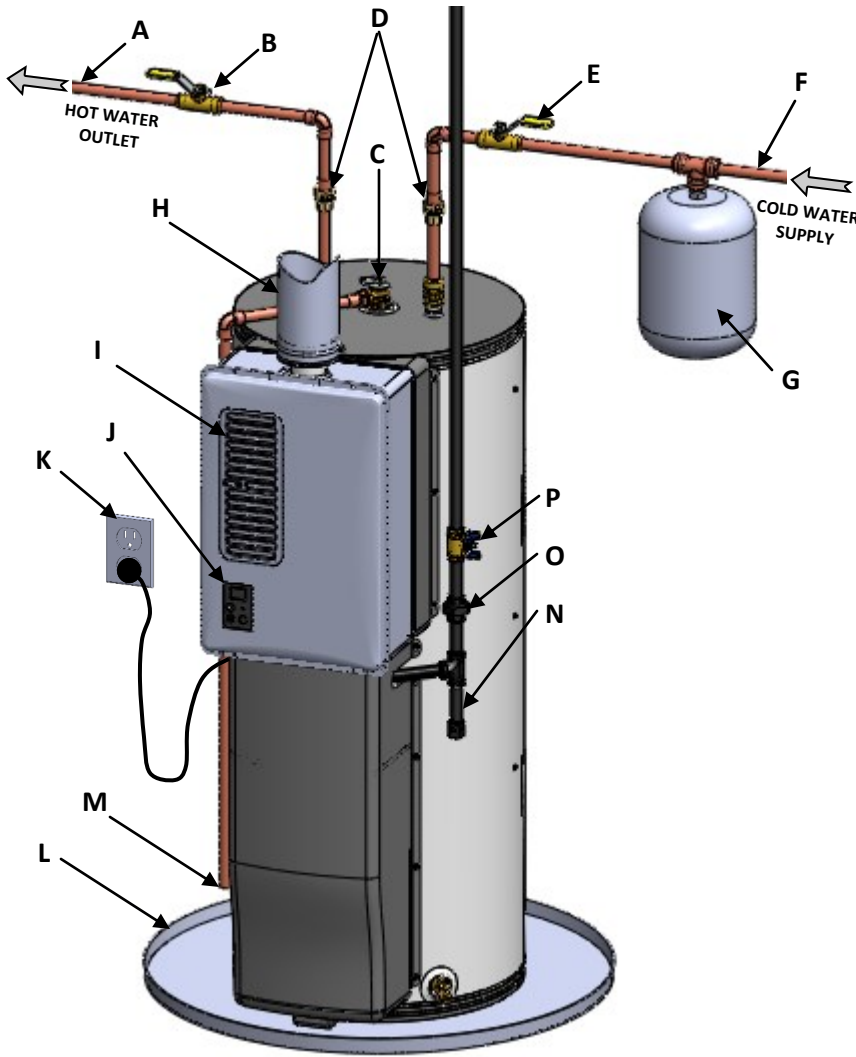

MIXING VALVE INSTALLATION

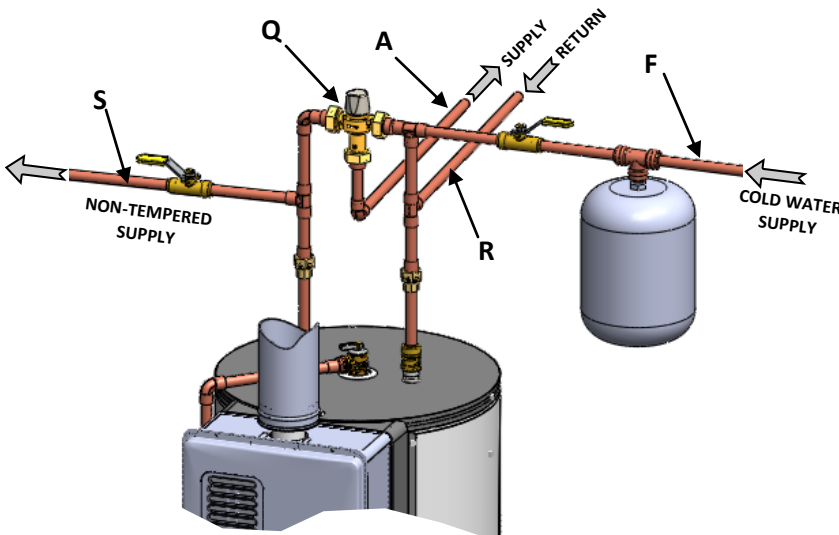

A	Hot Water Outlet	*
B	Hot Water Outlet Valve	*
C	Temperature-Pressure Relief Valve	
D	Cold and Hot Unions	*
E	Cold Water Supply Valve	*
F	Cold Water Supply	*
G	Thermal Expansion Tank	*
H	4" B-Vent	*
I	Combustion Air Screen	
J	Operation Unit / Temperature Control	
K	Outlet Receptacle	*
L	Drain Pan	*
M	Temperature-Pressure Relief Valve Discharge Pipe (do not cap, plug, or reduce)	*
N	Drip Leg (Sediment Trap)	*
O	Gas Union	*
P	Gas Control Valve	
Q	Thermostatic Mixing Valve	*
R	Non-Tempered Return Line	*
S	Non-Tempered Supply Line	*

* Field Supplied

Combustion Air Requirements

This water heater requires adequate combustion air for ventilation and dilution of flue gases. Failure to provide adequate combustion air can result in unit failure, fire, explosion, serious bodily injury or death. Use the following methods to ensure adequate combustion air is available for correct and safe operation of this water heater.

Important: Combustion air must be free of corrosive chemicals. Do not provide combustion air from corrosive environments. Appliance failure due to corrosive air is not covered by warranty.

Combustion air must be free of acid forming chemical such as sulfur, fluorine and chlorine. These chemicals have been found to cause rapid damage and decay and can become toxic when used as combustion air in gas appliances. Such chemicals can be found in, but not limited to bleach, ammonia, cat litter, aerosol sprays, cleaning solvents, varnish, paint and air fresheners. Do not store these products or similar products in the vicinity of this water heater.

Unconfined Space:

An unconfined space is defined in *National Fuel Gas Code, ANSI Z223.1/NFPA 54* as “a space whose volume is not less than 50 cubic feet per 1000 Btu/hr (4.8 m³ per kW per hour) of the aggregate input rating of all appliances installed in that space. Rooms communicating directly with the space in which the appliances are installed, through openings not furnished with doors, are considered a part of the unconfined space.” If the “unconfined space” containing the appliance(s) is in a building with tight construction, additional outside air may be required for proper operation. Outside air openings should be sized the same as for a confined space.

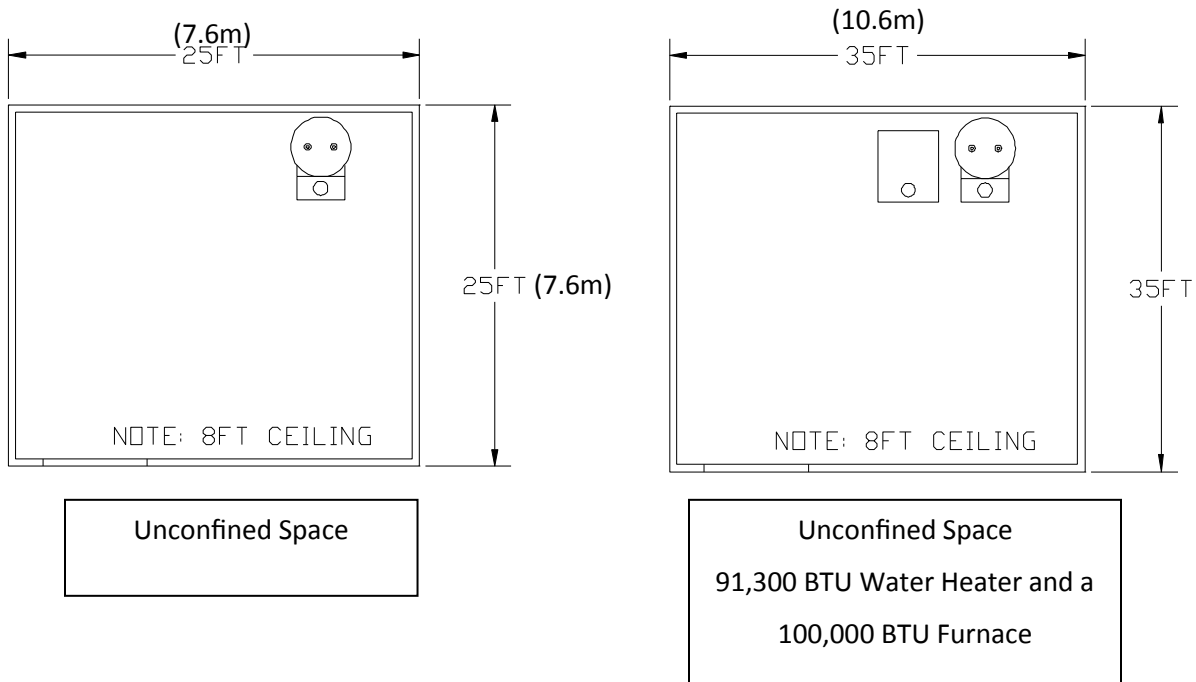

Combustion Air Requirements

Confined Space:

(Small Room, Closet, Alcove, Utility Room, Etc.)

A confined space is defined in the *National Fuel Gas Code, ANSI Z223.1/NFPA 54* as "a space whose volume is less than 50 cubic feet per 1000 Btu/hr (4.8 m³ per kW per hour) of the aggregate input rating of all appliances installed in that space." A confined space must have two combustion air openings. Size the combustion air openings based on the BTU input for all gas utilization equipment in the space and the method by which combustion air is supplied:

Louvers and Grills

When sizing the permanent opening as illustrated in Figure 1, consideration must be taken for the design of the louvers or grills to maintain the required free area required for all gas utilizing equipment in the space. If the free area of the louver or grill design is not available, assume wood louvers will have 25% free area and metal louvers or grills will have 75% free area. Under no circumstance should the louver, grill or screen have openings smaller than 1/4".

Example:

Wood: 10 in x 12 in x 0.25 = 30 in²

Metal: 10 in x 12 in x 0.75 = 90 in²

Location

To maintain proper circulation of combustion air two permanent openings (one upper, one lower) must be positioned in confined spaces. The upper shall be within 12 inches of the confined space and the lower opening shall be within 12 inches of the bottom of the confined space. Openings must be positioned as to never be obstructed.

Using Outdoor Air For Combustion

Outdoor air can be provided to a confined space

Combustion air provided to the appliance should not be taken from any area of the structure that may produce a negative pressure (i.e. exhaust fans, powered ventilation fans).

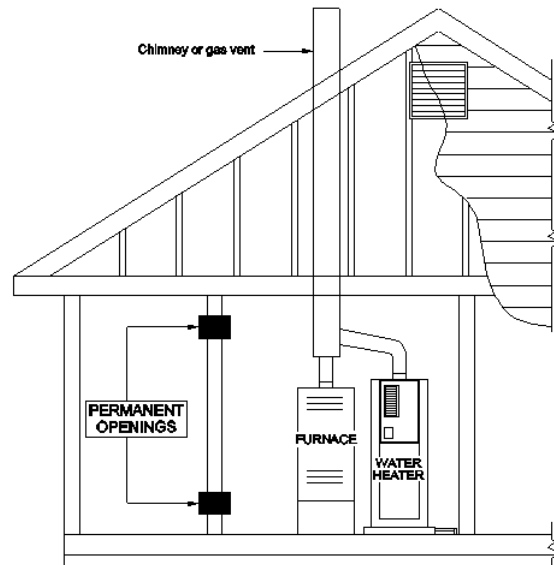
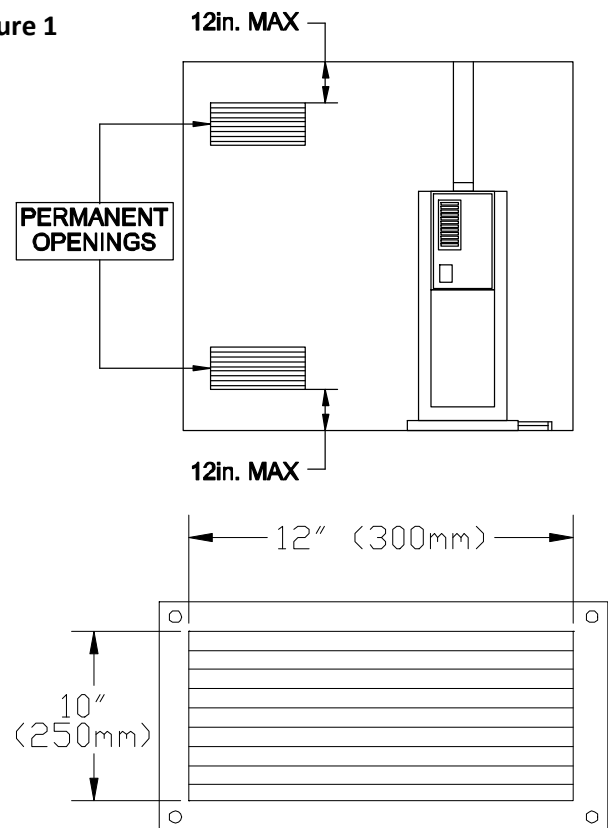

Figure 1



Combustion Air Requirements

Using Indoor Air For Combustion

When using air from other room(s) in the building, the total volume of the room(s) must be of adequate volume (Greater than 50 cubic feet per 1000 Btu/hr). Each Combustion air opening must have **at least one square inch of free area for each 1000 Btu/h**, but not less than 100 square inches each.

through two permanent openings, one commencing within 12 in. (300mm) of the top and one commencing within 12" (300mm) of the bottom, of the confined space. The openings shall communicate to the outside by one of two ways:

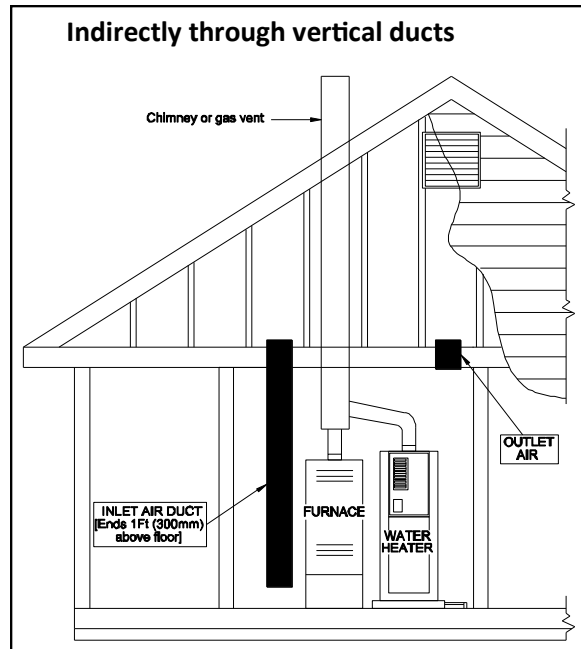
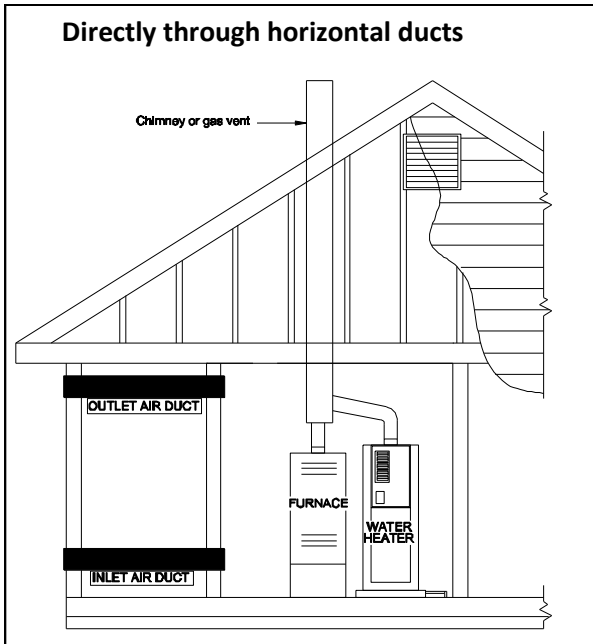

When communicating directly with the outdoors through horizontal ducts, each opening shall have a minimum free area of $1 \text{ in}^2/2000 \text{ Btu/hr}$ ($1100 \text{ mm}^2/\text{kW}$) of total input rating of all appliances in the confined space.

Note: If ducts are used, the cross sectional area of the duct must be greater than or equal to the required free area of the openings to which they are connected.

When communicating indirectly with the outdoors through vertical ducts, each opening shall have a minimum free area of $1 \text{ in}^2/4000 \text{ Btu/hr}$ ($550 \text{ mm}^2/\text{kW}$) of total input rating of all appliances in the confined space. Combustion air to the appliance can be provided from a well ventilated attic or crawl space.

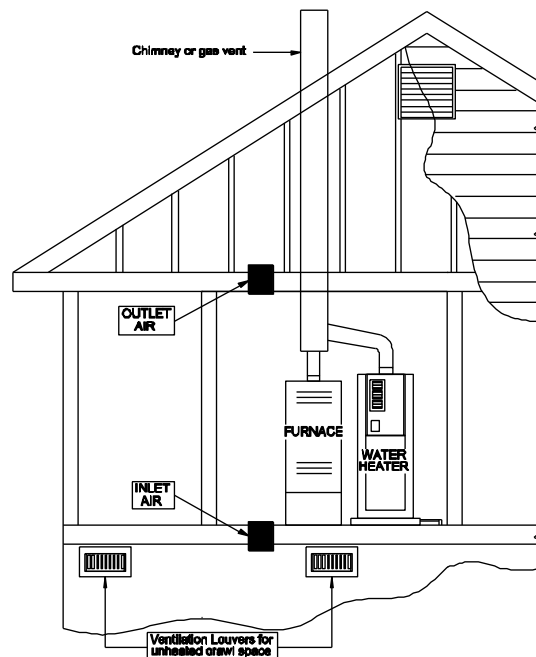

Venting Requirements

Venting

This water heater must be vented vertically to the outside of the building or structure.

This water heater is not designed or certified for side wall horizontal vent terminations.

All installations must be vented in accordance with *National Fuel Gas Code, ANSI Z223.1/NFPA 54* - latest edition and the requirements of state or local codes. In Canada, the furnaces must be vented in accordance with the National Standard of Canada, CAN/CSA B149.1 and CAN/CSA B149.2 - latest editions and amendments and the codes of the local utility or other authority having jurisdiction.

NOTE: The vertical height of the Category I venting system must be at least as great as the horizontal length of the venting system.

- All vent (Category I) passing through a concealed space, an attic or floor, MUST be Type B double wall vent and/or Type B double wall vent connectors. For vent passing through an interior wall, use Type B vent with ventilated thimble ONLY.
- The RH180 CANNOT be vented into any chimney serving an open fireplace or any other solid fuel burning appliance.
- Use the same diameter Category I connector or vent as permitted by NFPA 54/ANSI Z223.1 venting tables.
- It is not permitted to reduce vent diameter (4").
- It is emphasized that vertical Category I vent or vent connector runs be as short and direct as possible.
- Vertical outdoor runs of type B or ANY single wall vent below the roof line are NOT permitted.
- All horizontal vent runs to be sloped up away from the RH180 a minimum of 1/4" (6mm) per foot.
- All horizontal vent runs are to be supported, at a minimum, every 6' (2m) using suitable clamps and/or metal straps.
- Existing gas vent or chimney is to be checked to ensure they meet clearances and local codes.

The RH180 can ONLY be connected to a manufactured chimney or vent that complies with a recognized standard. Venting into a masonry or concrete chimney is only permitted as outlined in the NFPA 54/ANSI Z223.1 National Fuel Gas Code venting tables. It is therefore a contractual obligation on the part of the installer to follow all safe venting requirements.

!WARNING

Poison carbon monoxide gas hazard.

If this appliance is replacing a previously common vented water heater, it may be necessary to resize the existing chimney liner or vent to prevent over sizing problems for the other remaining appliance (s). See codes and/or standard having jurisdiction.

Failure to properly vent this water heating appliance or other appliance(s) can result in death, personal injury and/or property damage.

!WARNING

TO PREVENT POSSIBLE PERSONAL INJURY OR DEATH DUE TO ASPHYXIATION,

COMMON VENTING WITH OTHER MANUFACTURER'S INDUCED DRAFT APPLIANCES IS NOT ALLOWED.

!WARNING

Devices attached to the vent system intended to increase system efficiency by reducing the heat loss of the vent system MUST not be used on this water heater. Rinnai accepts no liability for damage or injury if such devices are installed on the vent system with this appliance.

!WARNING

Vent Pipe Assembly: To avoid damage to the vent and vent adapter, pre drill holes with a 1/8" drill bit. Attach the vent to the vent adapter with #8 screws.

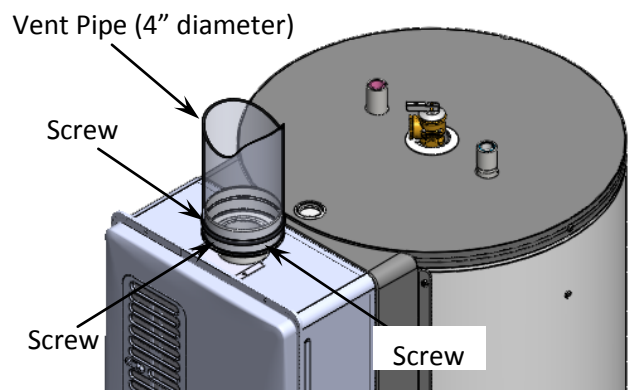

Venting Requirements

Vent Dampers

Vent dampers must be certified in accordance with ANSI Z21.68

Before installing any flue damper, consult the local gas authority and damper manufacturer for proper installation.

⚠️ WARNING

Thermal Operated Vent Dampers: Should NOT be used with this appliance. This appliance has a thermal efficiency greater than 80%. This higher efficiency will result in lower flue gas temperatures. Such temperatures may be too low to activate a thermal operated vent damper. Use of a thermal operated flue damper on this product may result in spillage of exhaust gases and ultimately carbon monoxide poisoning.

Vent Inspection

The entire vent system (Combustion air ducts, louvers etc., and exhaust vent) must be checked periodically for signs of obstruction or damage. If damaged components are observed they must be repaired or replaced immediately.

Vent Size

This water heater is equipped with a 4" vent adapter and must never be attached to a vent smaller than 4". Certain applications may require vent diameters greater than 4" Consult your local gas supplier or authority to aid in the proper vent diameter selection per the requirements of the vent tables in the current edition of the National Fuel Gas Code ANSI Z223.1/NFPA 54.

Vent Connectors

Vent Connectors are relatively short runs of vent connecting the appliance to the chimney or vertical vent run.

Following is a list of appropriate vent connector material for use between the water heater and the chimney:

- Type B (B-Vent) Double wall, U.L. listed vent pipe
- Type B (B-Vent) Single wall, U.L. listed vent pipe

Note the following when installing a vent connector from the appliance to the chimney or vertical vent:

Length: A vent connector shall be as short as practical and the appliance located as close as practical to the chimney or vent. The maximum horizontal length of the vent connector cannot exceed 75% of the height of the chimney or vent. Unnecessary bends should be avoided as to not create excessive resistance to flow of vent gases.

Prohibited locations: Vent Connectors cannot pass through any ceiling, floor, firewall, or fire partition.

Single wall vent connectors: A single wall vent connector must not pass through any interior walls, floors or ceilings. A single wall vent connector must not be installed in attics, crawl spaces or any other confined space or inaccessible location. Maintain a minimum of 6" from combustibles when using single walled vent connectors.

Double Walled, B-Vent: It is acceptable to pass through walls or partitions with double walled, B-Vent.

Slope: Vent connectors must pitch ¼ inch per foot (21mm per meter) upward.

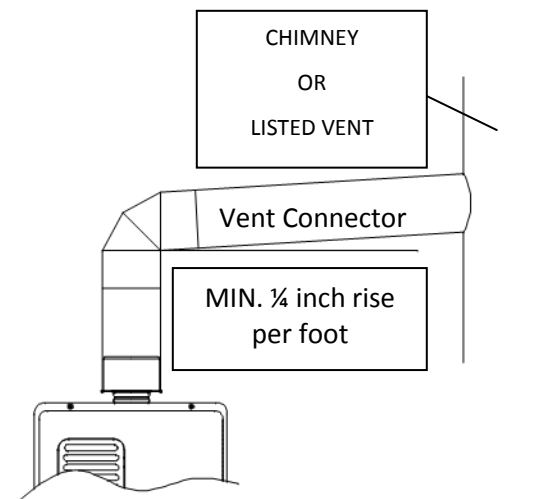

Venting Requirements

Inspection: The entire length of the vent connector shall be readily accessible for inspection, cleaning and replacement.

Joints: Must be fastened by sheet metal screws or other approved methods.

Support: Vent connectors must be supported per the vent manufacturer's installation instructions to avoid dips or sags in the vent and maintain the required clearances.

Vent Termination

All flue (Vent) gases must be directed to the outdoors of the building or structure and must not terminate horizontally.

Table 1

Roof Slope	H (minimum)	
	ft	m
Flat to 6/12	1.0	0.30
Over 6/12 to 7/12	1.25	0.38
Over 7/12 to 8/12	1.5	0.46
Over 8/12 to 9/12	2.0	0.61
Over 9/12 to 10/12	2.5	0.76
Over 10/12 to 11/12	3.25	0.99
Over 11/12 to 12/12	4.0	1.22
Over 12/12 to 14/12	5.0	1.52
Over 14/12 to 16/12	6.0	1.83
Over 16/12 to 18/12	7.0	2.13
Over 18/12 to 20/12	7.5	2.27
Over 20/12 to 21/12	8.0	2.44

Figure 2

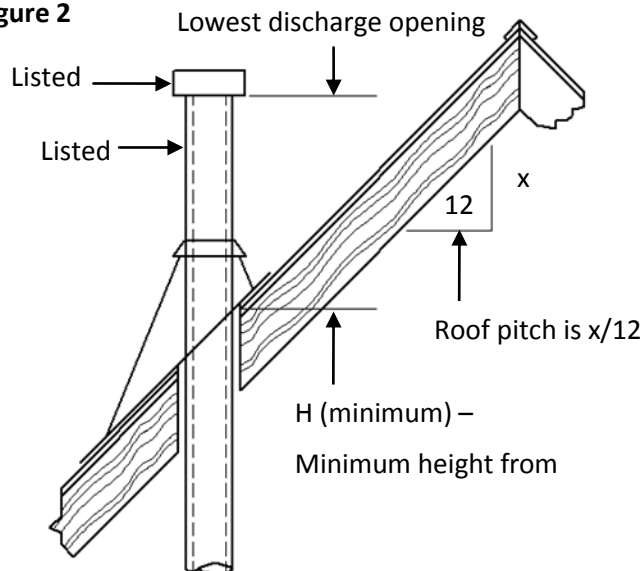

The vent termination shall comply with the following requirements:

If the gas vent is 12 inches (300mm) or less in diameter and located not less than 8 ft (2.4m) from a vertical wall or similar obstruction, the termination must comply with the requirements stated in Table 1 and Figure 2. If the gas vent is greater than 12 inches in diameter or located less than 8 ft (2.4m) from a vertical wall or similar obstruction, the termination must end not less than 2 ft (0.6m) above any portion of a building within 10ft (3.0m) horizontally.

B-Vent type gas vent shall terminate at least 5 ft (1.5m) in vertical height above the highest connected appliance draft hood or flue collar.

Decorative shrouds or coverings shall not be installed over the gas vent termination unless listed for use with the specific gas vent and are installed in accordance with the manufacturer's installation instructions.

All gas vents shall extend through the roof flashing, roof jack, or roof thimble and terminate with a listed cap or listed roof assembly.

The gas vent shall terminate at least 3 ft (0.9m) above any forced air inlet located within 10 ft (3.0m)

Venting Requirements

Masonry Vertical Venting

Masonry Chimneys shall be built and installed in accordance with NFPA 211, Standard for Chimneys, fireplaces, Vents and Solid Fuel-Burning Appliances.

Before assembling the vent connector to a chimney, the chimney must be inspected for signs of obstruction or damage. If previously used for solid or liquid fuel burning appliances or fireplaces, the chimney must be cleaned.

Do not connect the vent of this water heater to a chimney servicing a separate solid fuel burning appliance.

Do not connect the vent of this water heater to a tile lined masonry chimney. The chimney must be lined with either B-Vent or a listed chimney lining system.

Connection to a chimney must be firmly attached, sealed and must be located above the extreme bottom of the chimney.

B-Vent Vertical Venting

Vertical gas vent must be installed with U.L. listed type B-vent material in accordance with the manufacturer's installation instructions and the requirements stated in the "National Fuel Gas Code", NFPA 54, ANSI Z223.1- latest edition and the requirements of local codes.

Vent should extend in a generally vertical direction. Any vent angle less than 45 degrees is considered horizontal. The total horizontal distance of the vent system plus the horizontal length of the vent connector must not exceed 75 percent of the vertical height of the vent.

An unused chimney or masonry enclosure may be used as a chase for the installation of listed B-vent material.

Common Venting

As a Category I appliance, this water heater can be vented vertically with type B-1 vent systems and lined masonry chimneys. Follow the National Fuel Gas Code, ANSI Z223.1 and or the National Gas Installation code, CSA-B149.1 & .2 for proper installation practices. If you are unsure or need assistance in correct application of a common vent installation consult the local gas authority for assistance in the vent system design.

Checklist for Combustion Air and Venting Requirements

- Verify proper clearances around the vents .
- Ensure that the Combustion Air Requirements are followed that will provide sufficient combustion air for the appliance.
- Ensure you have used the correct venting products for Category 1 and that you have completely followed the venting manufacturer's installation instructions and these installation instructions. All installations must be vented in accordance with National Fuel Gas Code NFPA 54/ANSI Z223.1 - latest edition and the requirements of state or local codes. In Canada, the furnaces must be vented in accordance with the National Standard of Canada, CAN/CSA B149.1 and CAN/CSA B149.2 - latest editions and amendments and the codes of the local utility or other authority having jurisdiction.
- All horizontal vent runs must be sloped up away from the water heater a minimum of 1/4 " (6 mm) per foot.
- Verify that the vent termination clearances are followed.
- Verify that there is adequate combustion air.

Installation of Plumbing

Temperature-Pressure Relief Valve Requirements

Install the Temperature-Pressure Relief (T&P) Valve according to these instructions.

This water heater is provided with a combination temperature-pressure relief valve. For safe operation of the water heater, the relief valve(s) must not be removed from its designated point of installation or plugged.

(Ce chauffe-eau est équipé d'une soupape de décharge. Pour assurer le fonctionnement sécuritaire du chauffe-eau, ne pas retirer ni obturer cette soupape de décharge.)

An approved Temperature-Pressure Relief Valve is required by the *American National Standard (ANSI Z21.10.3)* for all water heating systems, and shall be accessible for servicing.

DO NOT

- Do not plug the T&P valve and do not install any reducing fittings or other restrictions in the relief line. The relief line should allow for complete drainage of the T&P valve and the line.
- Do not place any other type valve or shut off device between the relief valve and the water heater.

MUST DO

- The T&P valve must comply with the standard for *Relief Valves and Automatic Gas Shutoff Devices for Hot Water Supply Systems ANSI Z21.22* and /or the standard *Temperature, Pressure, Temperature and Pressure Relief Valves and Vacuum Relief Valves, CAN1-4.4*.
- The T&P valve must be rated up to 150 psi and to at least the maximum BTU/hr of the appliance.
- The discharge from the T&P Valve should be piped to the ground or into a drain system to prevent exposure or possible burn hazards to humans or other plant or animal life. Follow local codes. Water discharged from the relief valve could cause severe burns instantly, scalds, or death.
- The Temperature-Pressure Relief Valve must be manually operated once a year to check for correct operation.

INFORMATION

- If a T&P discharges periodically, this may be due to thermal expansion in a closed water supply system. Contact the water supplier or local plumbing inspector on how to correct this situation. Do not plug the relief valve.

Piping Requirements

A manual valve must be placed in the water inlet connection to the water heater before it is connected to the water line. Unions may be used on both the hot and cold water lines for future servicing and disconnection of the unit.

DO NOT

- Do not introduce toxic chemicals such as those used for boiler water treatment to the potable water used for space heating.

MUST DO

- The piping (including soldering materials) and components connected to this appliance must be approved for use in potable water systems.
- Purge the water line to remove all debris and air. Debris will damage the water heater.
- If the appliance will be used as a potable water source, it must not be connected to a system that was previously used with a nonpotable water heating appliance.
- Ensure that the water filter on the water heater is clean and installed.

Connect Water Heater to Water Supply

Water connections to the water heater should follow all state and local plumbing codes.

If this is a standard installation, refer to the Piping Diagram for Basic Installation.

1. Use of this layout should provide a trouble free installation for the life of the water heater. Before making the plumbing connections, locate the **COLD** water inlet and the **HOT** water outlet. These fittings are both 3/4" N.P.T. male thread. Make sure that the dip-tube is installed in the cold water inlet. Install a shut-off valve close to the water heater in the cold water line. It is recommended that unions be installed in the cold and hot water lines so that the water heater can be easily disconnected, if servicing is required.
2. When assembling the hot and cold piping, use a good food grade of pipe joint compound, and ensure all fittings are tight. It is imperative that open flame is not applied to the inlet and outlet fittings, as heat will damage or destroy the plastic lined fittings. This will **result in premature failure of the fittings, which is not covered by the warranty.**

Filling the Water Heater

DO NOT OPERATE THIS WATER HEATER UNLESS IT IS COMPLETELY FULL OF WATER. To prevent damage to the appliance all air must be relieved from the system and a hot water fixture must be flowing water before the water heater is plugged in and turned on. To ensure safe and effective operation of the water heater use the following filling procedure:

To fill the water heater:

1. Ensure the drain valve located at the bottom of the tank is closed.
2. Open nearest hot water fixture in the system.
3. Open the cold supply valve to the water heater.
4. Keep the hot water fixture open until the tank is filled and constant flow is obtained at the fixture.
5. Check water heater connections and plumbing system for damage or leaks. Repair if needed.

Checklist for Plumbing

- Purge the water line of all debris and air by closing the hot isolation valve and opening the cold isolation valve and its drain. **Debris will damage the water heater.** Use a bucket or hose if necessary.
- Ensure that hot and cold water lines are not crossed to the unit and are leak free.
- Ensure that the temperature & pressure relief valve is installed.
- Clean the inlet water filter. Refer to the "Water Filter Inspection, Detection and Cleaning" section in this manual for the water filter cleaning procedure.
- Check for proper water pressure to the water heater. Minimum water pressure is 20 psi. Rinnai recommends 30-50 psi for maximum performance.

Massachusetts - Required Plumbing

USE ONLY IN COMMONWEALTH OF MASSACHUSETTS

Combination Space Heating/Potable Water System

All water piping should be insulated in accordance with 780 CMR (Massachusetts Energy Code)

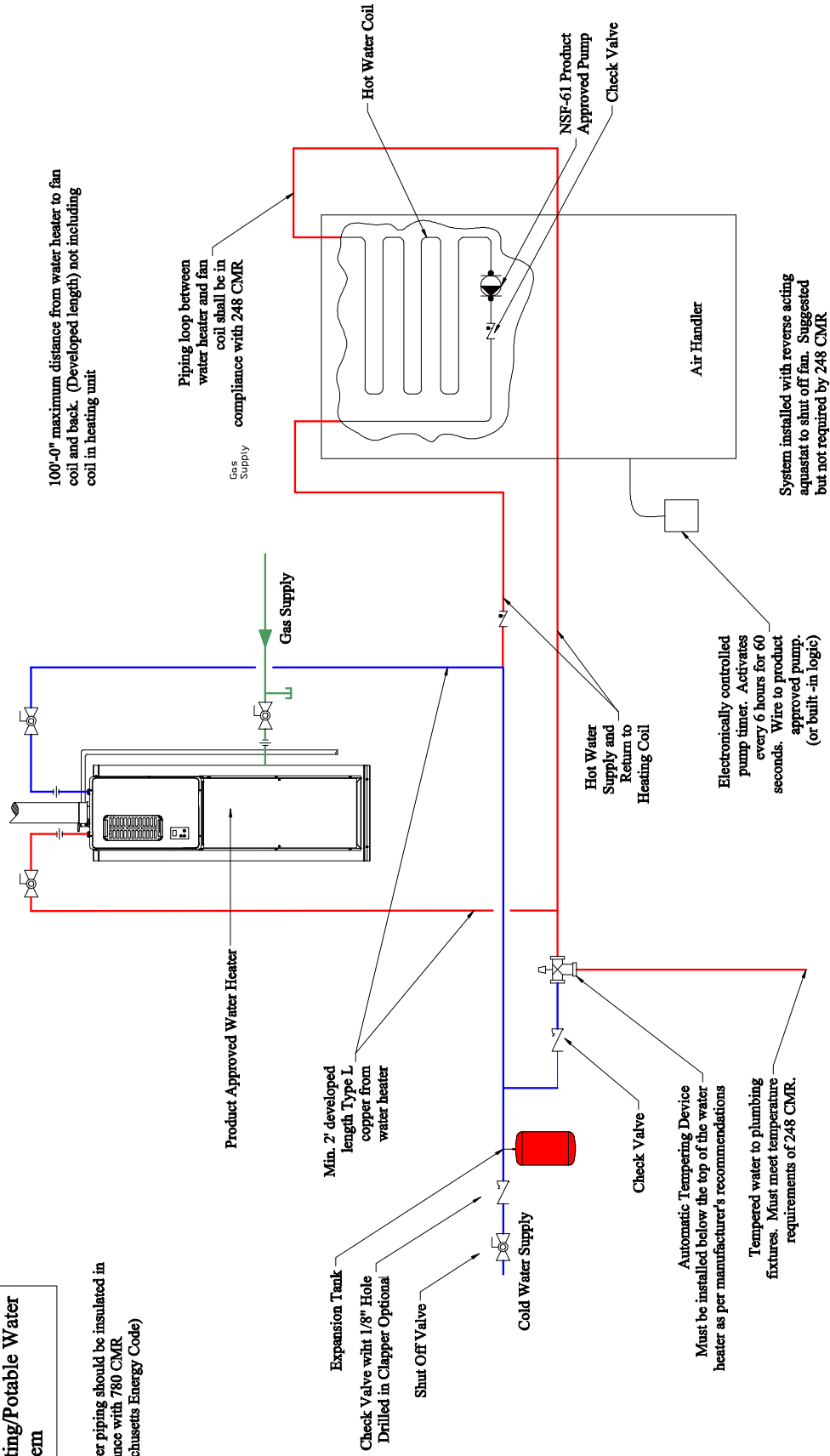

Installation of Gas Supply

! WARNING

1. If you are not knowledgeable or qualified to install gas lines or connections, then contact a licensed professional to install the gas supply.
2. Turn off 120v power supply.
3. Turn off the gas.
4. Gas is flammable. Do not smoke or provide other ignition sources while working with gas.
5. Do not turn on the water heater or gas until all fumes are gone.

General Instructions

In order to access the gas connections, remove the screws that attach the lower enclosure to the assembly

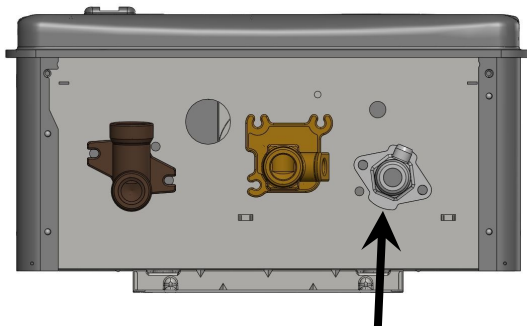
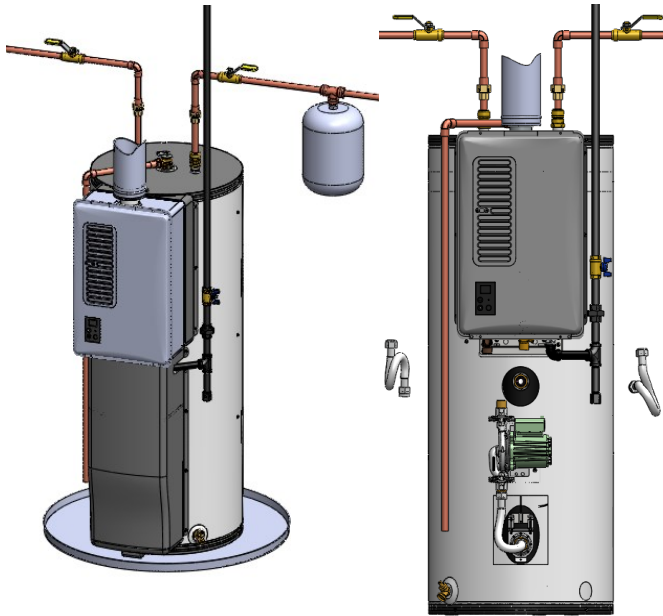

Gas Connection (1/2" MNPT)

MUST DO

- A manual gas control valve must be placed in the gas supply line to the water heater. A union can be used on the connection above the shut off valve for the future servicing or disconnection of the unit.
- Check the type of gas and the gas inlet pressure before connecting the water heater. If the water heater is not of the gas type that the building is supplied with, DO NOT connect the water heater. Contact the dealer for the proper unit to match the gas type.
- Check the gas supply pressure immediately upstream at a location provided by the gas company. Supplied gas pressure must be within the limits shown in the Specifications section with all gas appliances operating.
- Before placing the appliance in operation all joints including the heater must be checked for gas tightness by means of leak detector solution, soap and water, or an equivalent nonflammable solution, as applicable. (Since some leak test solutions, including soap and water, may cause corrosion or stress cracking, the piping shall be rinsed with water after testing, unless it has been determined that the leak test solution is non-corrosive.)
- Use approved connectors to connect the unit to the gas line. Purge the gas line of any debris before connection to the water heater.
- Any compound used on the threaded joint of the gas piping shall be a type which resists the action of liquefied petroleum gas (propane / LPG).
- The gas supply line shall be gas tight, sized, and so installed as to provide a supply of gas sufficient to meet the maximum demand of the heater and all other gas consuming appliances at the location without loss of pressure.
- Always check all gas pipe connections and fittings for leaks before operating the water heater. Use soapy water on all fitting and visually inspect for bubble formation. Rinse off soapy water and wipe dry.

INFORMATION

- Refer to an approved pipe sizing chart if in doubt about the size of the gas line.

Size the gas pipe

The gas supply must be capable of handling the entire gas load at the location. Gas line sizing is based on gas type, the pressure drop in the system, the gas pressure supplied, and gas line type. For gas pipe sizing in the United States, refer to the *National Fuel Gas Code, NFPA 54*. The below information is provided as an example. The appropriate table from the applicable code must be used.

1. For some tables, you will need to determine the cubic feet per hour of gas required by dividing the gas input by the heating value of the gas (available from the local gas company). The gas input needs to include all gas products at the location and the maximum BTU usage at full load when all gas products are in use.
2. Use the table for your gas type and pipe type to find the pipe size required. The pipe size must be able to provide the required cubic feet per hour of gas or the required BTU/hour.

$$\text{Cubic Feet per Hour} = \frac{\text{Gas Input of all gas products (BTU / HR)}}{\text{Heating Value of Gas (BTU / FT}^3\text{)}}$$

Example:

The heating value of natural gas for your location is 1000 BTU/FT³. The gas input of the RH180 is 91,500 BTU/HR. Additional appliances at the location require 65,000 BTU/hr. Therefore the cubic feet per hour = (91,500 + 65,000) / 1000 = 156.5 FT³/HR. If the pipe length is 10 feet then the 3/4 inch pipe size is capable of supplying 156.5 FT³/HR of natural gas.

Pipe Sizing Table - Natural Gas

Schedule 40 Metallic Pipe

Inlet Pressure: less than 2 psi (55 inches W.C.)

Pressure Drop: 0.3 inches W.C.

Specific Gravity: 0.60

Capacity in Thousands of BTU per Hour

Length	Pipe Size (inches)			
	1/2	3/4	1	1 1/4
10	131	273	514	1060
20	90	188	353	726
30	—	151	284	583
40	—	129	243	499
50	—	114	215	442
60	—	104	195	400
70	—	95	179	368
80	—	89	167	343
90	—	83	157	322
100	—	79	148	304

Pipe Sizing Table - Propane Gas

Schedule 40 Metallic Pipe

Inlet Pressure: 11.0 inches W.C.

Pressure Drop: 0.5 inches W.C.

Specific Gravity: 1.50

Capacity in Thousands of BTU per Hour

Length	Pipe Size (inches)			
	1/2	3/4	1	1 1/4
10	291	608	1150	2350
20	200	418	787	1620
30	160	336	632	1300
40	137	287	541	1110
50	122	255	480	985
60	110	231	434	892
80	101	212	400	821
100	94	197	372	763

Connect Electricity

! WARNING

Do not use an extension cord or an adapter plug with this appliance.

The water heater must be electrically grounded in accordance with local codes and ordinances or, in the absence of local codes, in accordance with the National Electrical Code, ANSI/NFPA No. 70.

Water heaters are equipped with a three-prong (grounding) plug for your protection against shock hazard and should be plugged directly into a properly grounded three-prong receptacle. Do not cut or remove the grounding terminal from this plug.

Do not rely on the gas or water piping to ground the water heater. A screw is provided in the junction box for the grounding connection.

The water heater requires 120 VAC, 60 Hz power from a properly grounded circuit.

If using the 5 foot long power cord, plug it into a standard 3 prong 120 VAC, 60 Hz properly grounded wall outlet.

If any of the original wire as supplied with the appliance must be replaced, it must be replaced with CP-90580 wire or its equivalent.

(Si un des conducteurs d'origine fourni avec l'appareil doit être remplacé, utiliser un conducteur CP-90580, ou l'équivalent.)

Adjust for High Altitude

Set switches 2 and 3 to the values shown in table below for your altitude. The default setting for the appliance is 0-2000 ft (0-610 m) with switches No. 2 and No. 3 in the OFF position.

Altitude	Switch No. 2	Switch No. 3
0-2000 ft (0-610 m)	OFF	OFF
2001-5400 ft (610-1646 m)	OFF	ON

Dip Switch Settings

Switch No. 2	OFF	OFF
Switch No. 3	OFF	ON

SWITCH		SWITCH	
	→ ON		→ ON
O	□	1	□
F	■	2	■
F	□	3	□
	□	4	■
	□	5	□
	□	6	□
	□	7	□
	□	8	□

Checklist for Gas and Electricity

- A manual gas control valve is placed in the gas line to the water heater.
- Check the gas lines and connections for leaks.
- Confirm that the gas inlet pressure is within limits.
- Confirm that the water heater is rated for the gas type supplied.
- Confirm that the electricity is supplied from 120 VAC, 60 Hz power source and is in a properly grounded circuit.
- An extension cord or an adapter plug has not been used with the water heater.

Final Checklist

- The water heater is not exposed to corrosive compounds in the air.
- The water heater location complies with the clearances.
- The water supply does not contain chemicals or exceed total hardness that will damage the heat exchanger.
- Ensure the water heater and its water lines are protected from freezing. Damage due to freezing is not covered by the warranty.
- Confirm that the electricity is supplied from a 120 VAC, 60 Hz power source, is in a properly grounded circuit, and turned on.
- The installation must conform with local codes or, in the absence of local codes, with the *National Fuel Gas Code, ANSI Z223.1/NFPA 54*, or the *Natural Gas and Propane Installation Code, CSA B149.1*.
- Verify proper clearances around the vents and air intakes.
- Ensure that the Combustion Air Requirements are followed that will provide sufficient combustion air for the appliance.
- Ensure you have used the correct venting products for the model installed and that you have completely followed the venting manufacturer's installation instructions and these installation instructions.
- The water heater must be vented vertically to the outside of the building or structure.
- Purge the water line of all debris. **Debris will damage the water heater.** Use a bucket or hose if necessary.
- Ensure the water heater is vented in accordance with *National Fuel Gas Code, ANSI Z223.1/NFPA 54* - latest edition and the requirements of state or local codes.
- Ensure that hot and cold water lines are not crossed to the unit and are leak free.
- Clean the inlet water filter by first powering OFF the water heater. Remove the lower enclosure. Drain and relieve the pressure from the system. Remove and clean the filter of any debris that may reduce water flow. Once clean, replace the filter. Close the drain valve and pressurize the system. Power the unit back ON and set desired temperature. For more information on cleaning the filter please reference **page 39** section **C**.
- Ensure that the temperature/pressure relief valve is installed.
- Check for proper water pressure to the water heater. Minimum water pressure is 20 psi. Rinnai recommends 30-50 psi for maximum performance.
- A manual gas control valve has been placed in the gas line to the water heater.
- Check the gas lines and connections for leaks.
- Confirm that the gas inlet pressure is within limits.
- Confirm that the water heater is rated for the gas type supplied.
- An extension cord or an adapter plug has not been used with the water heater.
- Verify the system is functioning correctly by connecting your manometer to the gas pressure test port on the water heater. Operate all gas appliances in the home or facility at high fire. The inlet gas pressure at the water heater must not drop below that listed on the rating plate.
- Ensure the lower enclosure is installed.
- Explain to the customer the importance of not blocking the vent termination or air intake.
- Explain to the customer the operation of the water heater, safety guidelines, maintenance, and warranty.
- Inform the consumer of the importance of good water quality and its effects on the warranty.
- Leave the entire manual taped to the water heater, or give the entire manual directly to the consumer.**

Technical Data

Specifications

<i>Model</i>		<i>RH180</i>
Minimum Gas Consumption Btu/h		Natural Gas: 59,500 BTU/Hr Propane: 47,600 BTU/Hr
Maximum Gas Consumption Btu/h		Natural Gas: 91,300 BTU/Hr Propane: 87,300 BTU/Hr
First Hour Rating		180 GPH
Storage Tank Volume		40 gallons
Recovery (100° Rise)		89 GPH
Temperature Selections		110, 120, 130, 135, 140
Maximum Temp Setting		140° F (60° C)
Minimum Temperature Setting		110° F (43° C)
Weight		150lb (68kg)
Thermal Efficiency		80%
Noise level		50 dB
Electrical Consumption	Standby	3 Watts
	Operation	150 Watts
	Fuse	5 Amps
Minimum Gas Supply Pressure	Natural Gas	4.0 inch W.C.
	Propane	8.0 inch W.C.
Maximum Gas Supply Pressure	Natural Gas	10.5 inch W.C.
	Propane	13.5 inch W.C.
Type of Appliance		Automatic Circulating Tank Water Heater
Approved Gas Type		Natural Gas or Propane - Ensure unit matches gas type supplied at the installation location.
Connections		Gas Supply: 1/2" MNPT, Cold Water Inlet: 3/4" MNPT, Hot Water Outlet: 3/4" MNPT
Ignition System		Direct Electronic Ignition
Electric Connections		Appliance: AC 120 Volts, 60Hz.
Water Temperature Control		Simulation Feedforward and Feedback.
Water Supply Pressure		Minimum Water Pressure: 20 PSI (Recommended 30-50 PSI for maximum performance)
Maximum Water Supply Pressure		150 PSI
Sensor and Switches		Flammable Vapor Sensor
		Combustion Air Co Sensor
		Bi-Metal Overheat Switch

Rinnai is continually updating and improving products. Therefore, specifications are subject to change without prior notice.

The maximum inlet gas pressure must not exceed the value specified by the manufacturer. The minimum value listed is for the purpose of input adjustment.

Dimensions

Inches (millimeters)

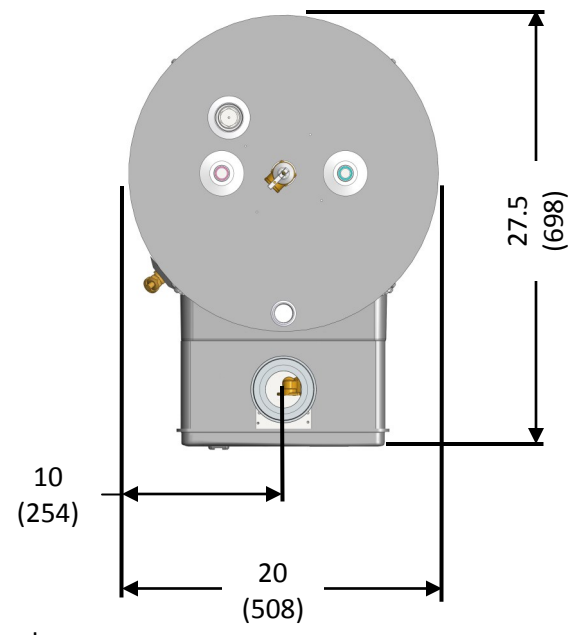
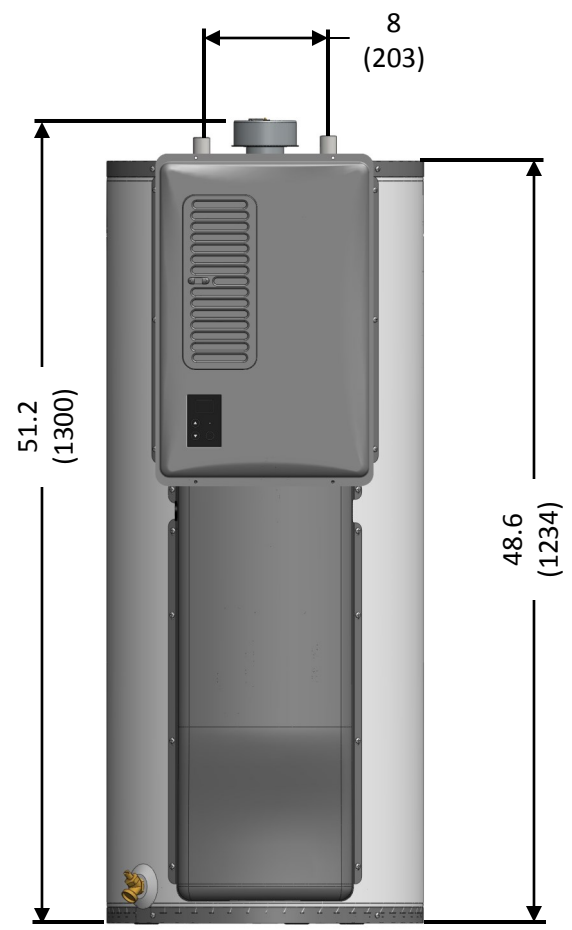
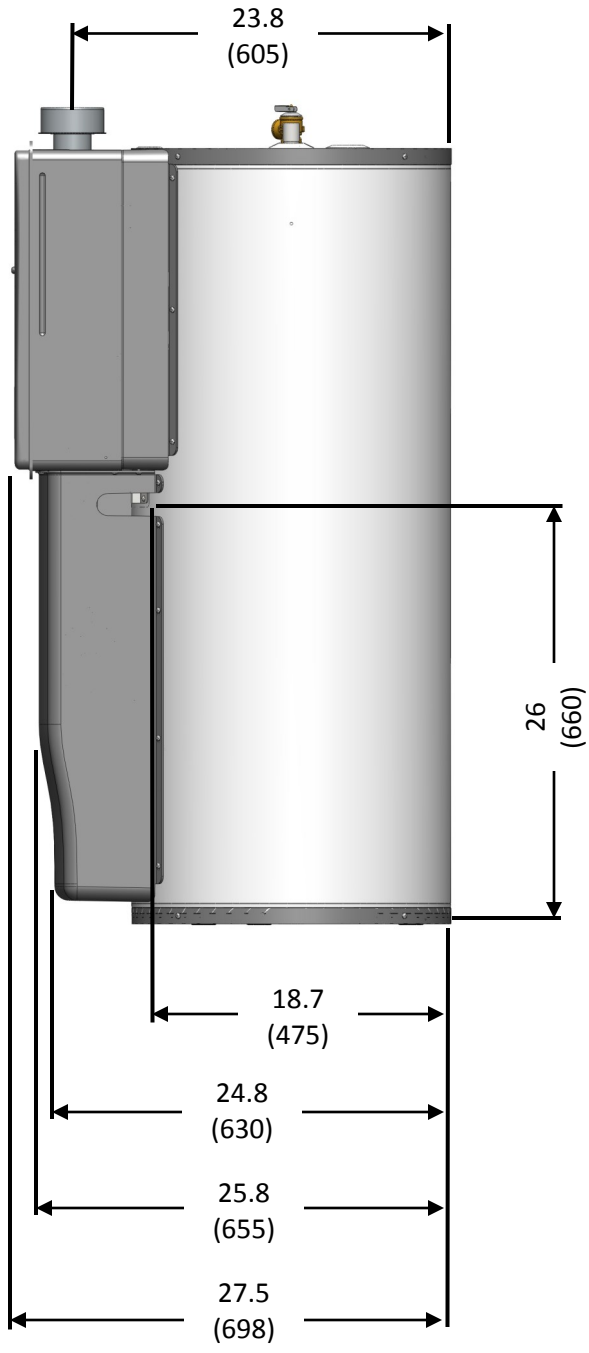

Wire Diagram

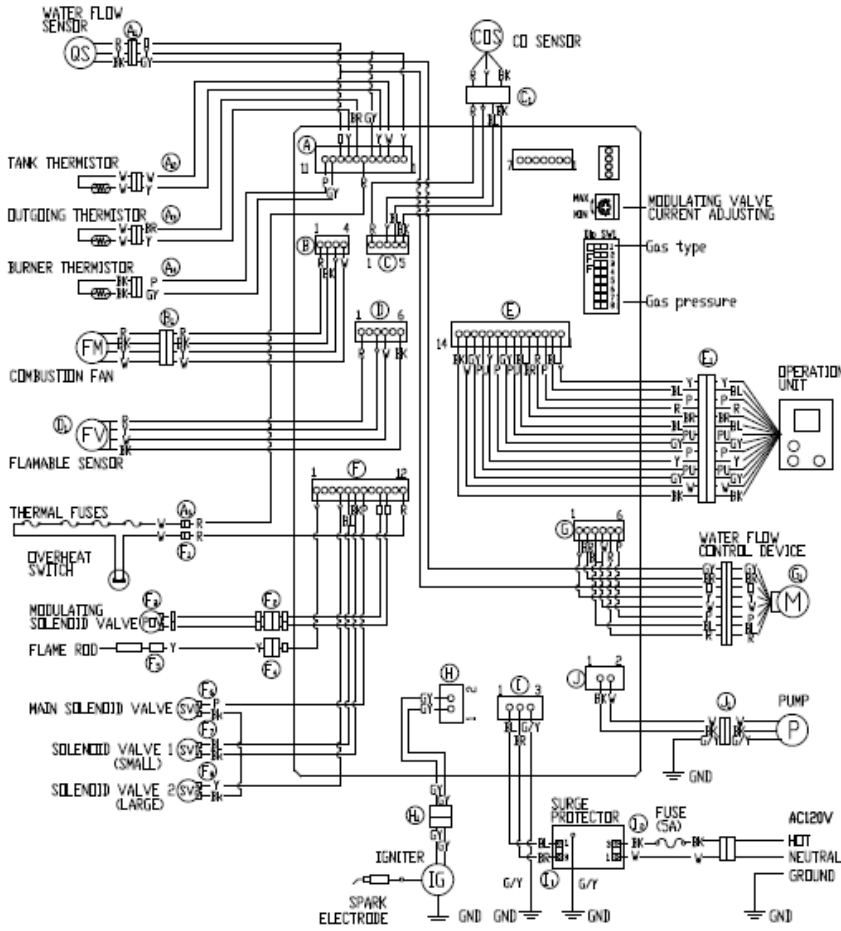

Wire Color Legend

W:.....WHITE
 BK:....BLACK
 BR:....BROWN
 R:.....RED

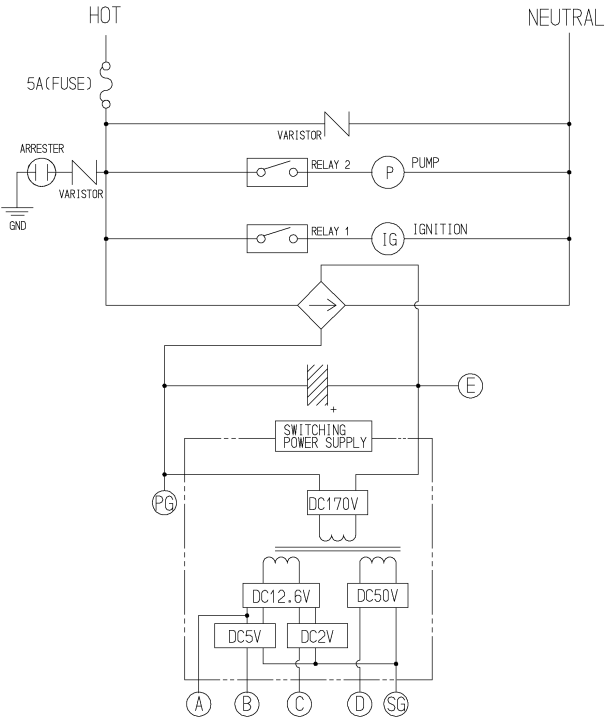
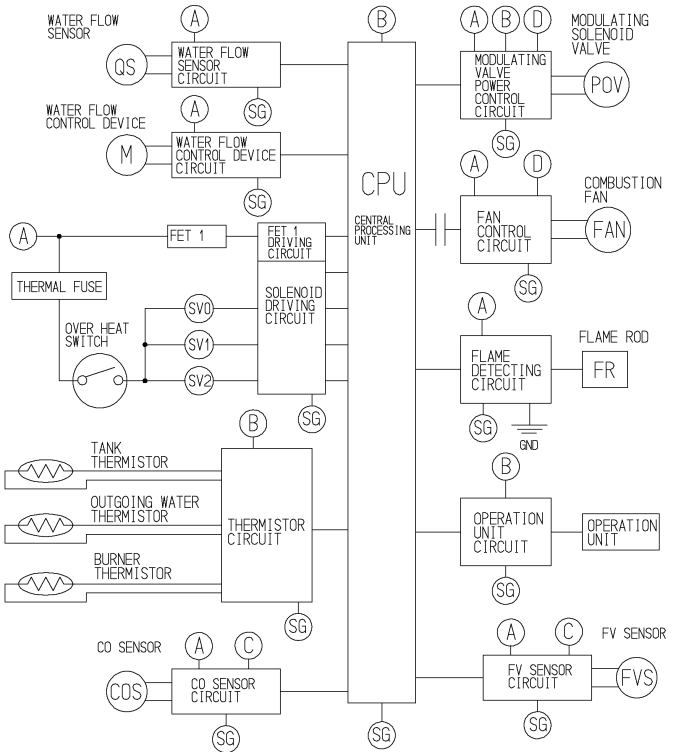
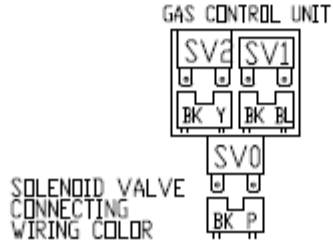

Parts Breakdown

ITEM NO.	DESCRIPTION OF ENGINE PARTS
2	EXHAUST DUCT BOX
3	OVERHEAT SWITCH
4	HEAT EXCHANGER
5	THERMAL FUSE
6	ELECTRODE
7	FLAME ROD
8	MANIFOLD ASSEMBLY
9	P.C.B.
10	IGNITER
11	SURGE PROTECTOR
12	GAS CONTROL ASSEMBLY
13	GAS CONNECTION
14	DRAIN VALVE
15	HOT WATER OUTLET
17	COMBUSTION FAN
18	WATER INLET
19	WATER FILTER ASSEMBLY
20	WATER FLOW SENSOR
21	WATER FLOW CONTROL DEVICE
23	OPERATION UNIT
24	COMBUSTION AIR ASSEMBLY
25	FLAMMABLE VAPOR ASSEMBLY
26	BURNER THERMISTOR
27	COMBUSTION CHAMBER FRONT PLATE ASSEMBLY
28	OUTGOING WATER THERMISTOR
29	WALL INSTALLATION BRACKET
30	CO SENSOR
31	EXHAUST OUTLET ASSEMBLY
32	FRONT PANNEL ASSEMBLY
33	MAIN BURNER

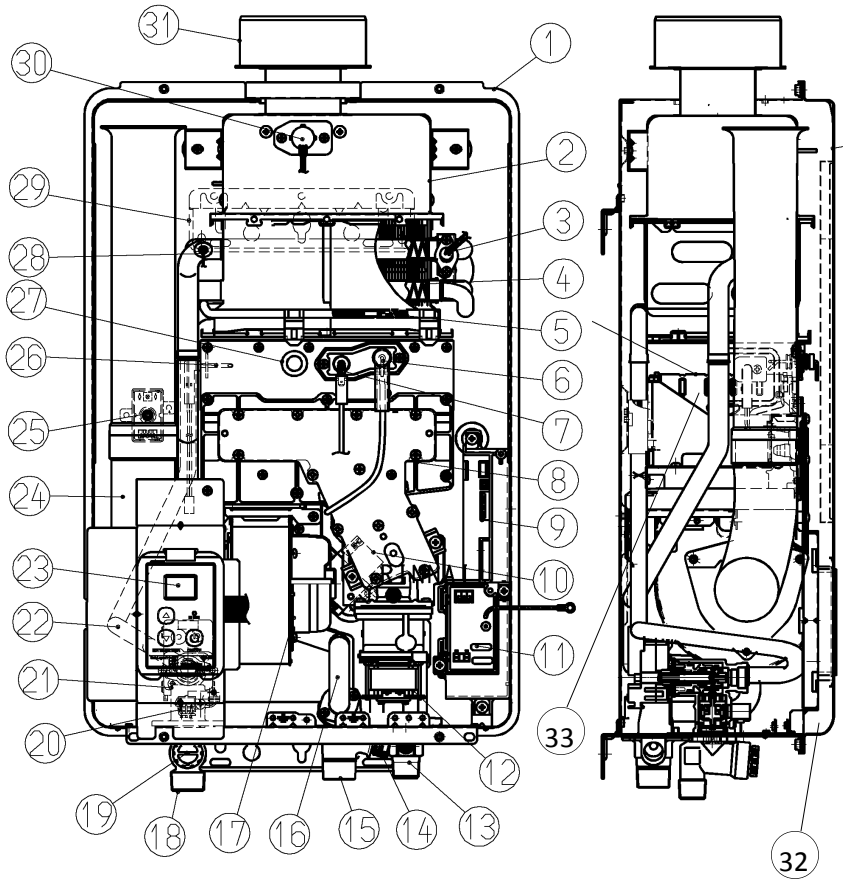

ITEM NO.	DESCRIPTION OF TANK PARTS
1	ENGINE
2	PUMP
2*	ALTERNATIVE PUMP WITHOUT FLANGE (OPTIONAL)
3	T & P VALVE
4	ANODE
5	J-TUBE
6	DIPTUBE
7	OUTLET NIPPLE
8	DRAIN VALVE
9	THERMOSTAT BRACKET
10	THERMOSTAT BRACKET
11	FLEXIBLE HOSE
12	FLEXIBLE HOSE
13	FRONT COVER
14	SIDE TRIM
15	THERMISTOR
16	SHOE-HORSE GROMMET
17	HEXAGONAL REDUCING BUSHING
18	CLOSE NIPPLE
19	FLANGE SET

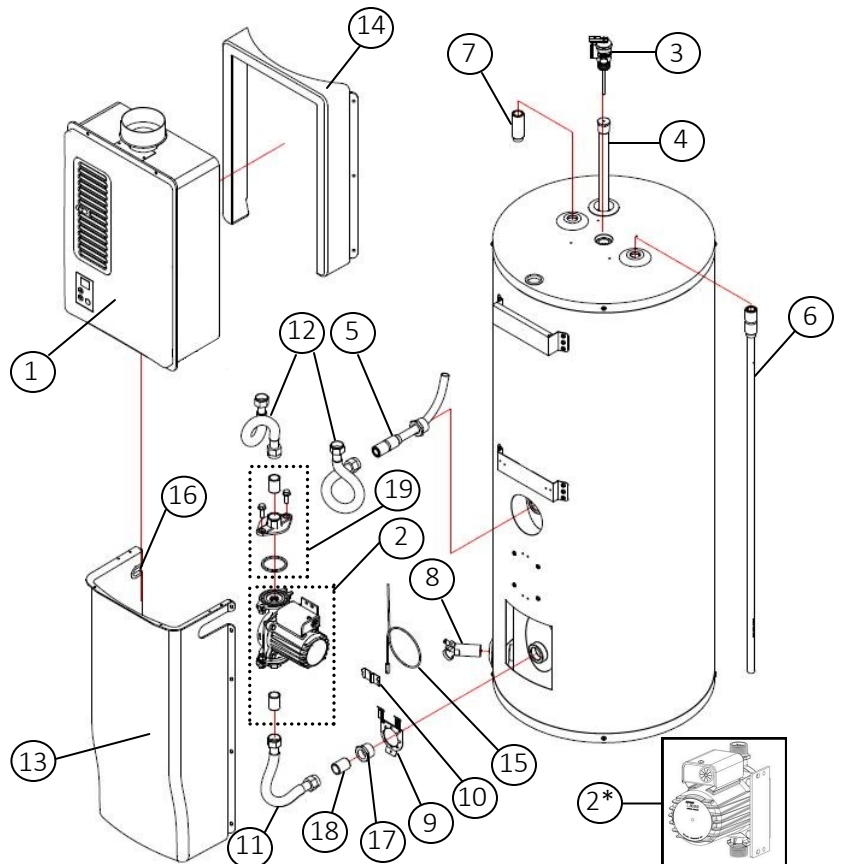

(Optional aluminum anode part # is 107000127)

Consumer Operation Guidelines for the Safe Operation of your Water Heater

FOR YOUR SAFETY READ BEFORE OPERATING



WARNING: If you do not follow these instructions exactly, a fire or explosion may result causing property damage, personal injury or loss of life.



BEFORE LIGHTING: ENTIRE SYSTEM MUST BE FILLED WITH WATER AND AIR PURGED FROM ALL LINES.

A. This appliance does not have a pilot. It is equipped with an ignition device which automatically lights the burner. Do not try to light the burner by hand.

B. BEFORE OPERATING smell all around the appliance area for gas. Be sure to smell next to the floor because some gas is heavier than air and will settle on the floor.





WHAT TO DO IF YOU SMELL GAS

- Do not try to light any appliance.
- Do not touch any electric switch; do not use any phone in your building.
- Immediately call your gas supplier from a neighbor's phone. Follow the gas supplier's instructions.
- If you cannot reach your gas supplier, call the fire department.

C. Use only your hand to push in or turn the gas control knob. Never use tools. If the knob will not push in or turn by hand, don't try to repair it, call a qualified service technician. Force or attempted repair may result in a fire or explosion.

D. Do not use this appliance if any part has been under water. Immediately call a qualified service technician to inspect the appliance and to replace any part of the control system and any gas control which has been under water.

OPERATING INSTRUCTIONS

1.  **STOP!** Read the safety information above on this label.
2. Set the thermostat to the lowest setting
3. Turn off all electric power to the appliance.
4. This appliance is equipped with an ignition device which automatically lights the burner. Do not try to light the burner by hand.
5. Turn the manual gas control valve located at the gas inlet of the appliance clockwise  to the OFF position
6. Wait five (5) minutes to clear out any gas. If you then smell gas,  **STOP!** Follow "B" in the safety information above on this label. If you don't smell gas, go to next
7. Turn the manual gas control valve located at the gas inlet of the appliance counterclockwise  to the ON position.
8. Turn on all electrical power to the appliance.
9. Set the thermostat to desired setting.
10. If the appliance will not operate, follow the instructions "To Turn Off Gas To Appliance" and call your service technician or gas supplier.

TO TURN OFF GAS TO APPLIANCE

1. Set the thermostat to lowest setting.
2. Turn off all electric power to the water heater if service is to be performed.
3. Turn the manual gas valve at the gas inlet of the appliance clockwise  to the "OFF" position.

How to Use the Temperature Controller

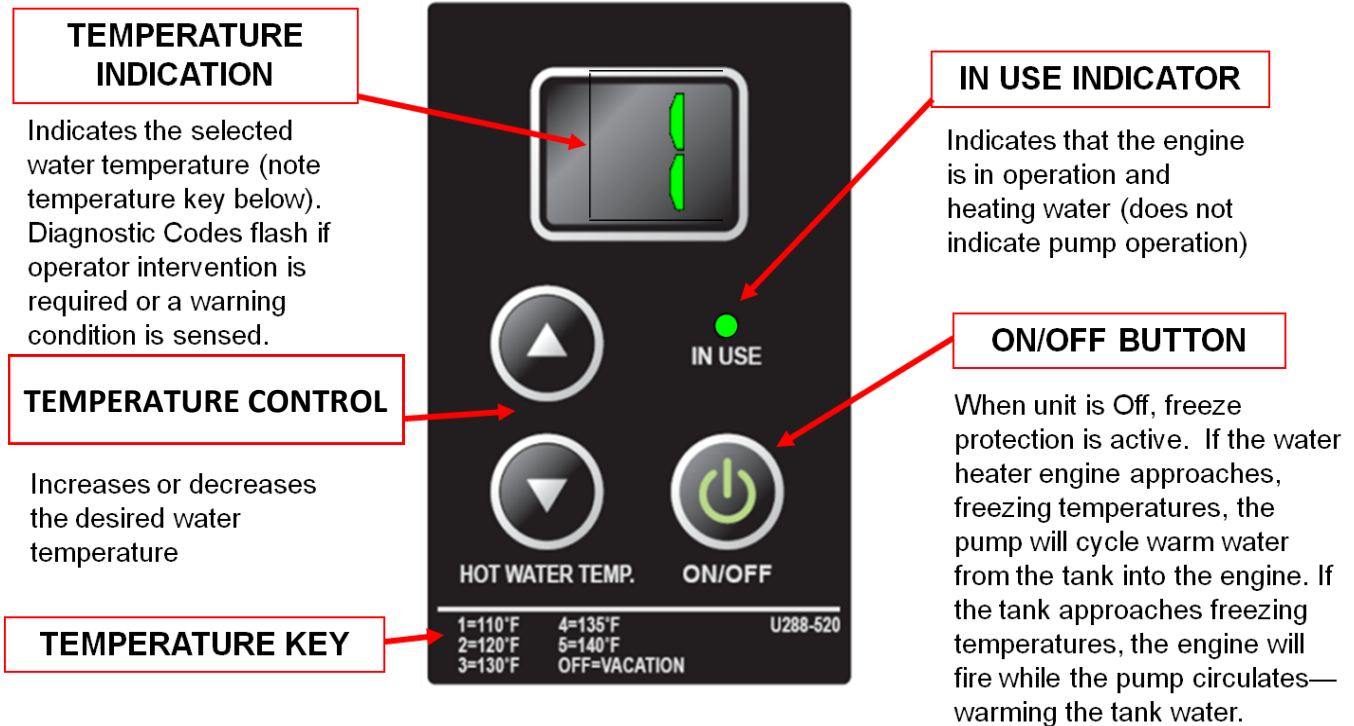

Note: Freeze protection will activate as long as gas and electricity are available.

Five temperature settings are available. Push the up and down arrows to choose your desired temperature setting. The number on the display corresponds to the temperatures below:

1=110°F

2=120°F

3=130°F

4=135°F

5=140°F

To display the recovery flow rate in gallons per minute through the unit (not to the fixture), press the UP button for 3 seconds, followed by ON/OFF.

To display the temperature supplied to the storage tank in degrees Fahrenheit, press the DOWN button for 3 seconds followed by ON/OFF.

(Note: temperature will display only one or two digits, Examples: 8 = 80 to 89 and 14 = 140 to 149)



WARNING

- Before operating, smell all around the appliance area for gas. Be sure to smell next to the floor because some gas is heavier than air and will settle on the floor.
- Keep the area around the appliance clear and free from combustible materials, gasoline, and other flammable vapors and liquids.
- Always check the water temperature before entering a shower or bath.
- Do not use this appliance if any part has been under water. Immediately call a licensed professional to inspect the appliance and to replace any part of the control system and any gas control which has been under water.

(N'utilisez cet appareil si l'alimentation a été plonge dans l'eau, même partiellement. Faites inspecter l'appareil par un technicien qualifié et remplacez toute partie du système de contrôle et toute commande qui ont été plongés dans l'eau.)

- Should overheating occur or the gas supply fail to shut off, turn off the manual gas control valve to the appliance.
(En cas de surchauffe ou si l'alimentation en gaz ne s'arrête pas, fermez manuellement le robinet d'arrêt de l'admission de gaz.)
- Do not adjust the DIP switch unless specifically instructed to do so.
- Do not use an extension cord or an adapter plug with this appliance.
- Any alteration to the appliance or its controls can be dangerous and will void the warranty.

If you install this water heater in an area that is known to have hard water or that causes scale build-up the water must be treated and/or the heat exchanger flushed regularly. Rinnai provides a "Scale Control System" that offers superior lime scale prevention and corrosion control by feeding a blend of control compounds into the water supply. Damage and repair due to scale in the heat exchanger is not covered by warranty.

Keep the air intake location free of chemicals such as chlorine or bleach that produce fumes. These fumes can damage components and reduce the life of your appliance. Damage and repair due to corrosive compounds in the air is not covered by warranty.

Diagnostic Codes and Remedies



WARNING

Some of the checks below should be done by a licensed professional. Consumers should never attempt any action that they are not qualified to perform.

Code	Definition		Remedy
05	Air Filter Error		Follow the procedure “Air Screen Inspection, Detection & Cleaning” in this manual. If the error code continues to flash after cleaning the air filter, review the items in “Code 10” or contact a qualified service technician.
07	Circulation Flow Rate Has Dropped Below 2.1gpm		Check water filter for blockage Check pump operation and wiring Clean Heat Exchanger
10	Air Supply or Exhaust Blockage		Check that nothing is blocking the vent, inlet screen or “Combustion Air Assembly” Check all vent components for proper connections.
		licensed professional only	Ensure listed 4” b-vent is used and there are no reductions in the vent system Check fan for blockage Ensure vent length, vent size and combustion air comply with the requirements stated in the <i>National Fuel Gas Code, ANSI Z223.1/NFPA 54, or the Natural Gas and Propane Installation Code, CSA B149.1.</i>
11	No Ignition		Check that the gas is turned on at the water heater, gas meter, or cylinder. Ensure appliance is properly grounded.
		licensed professional only	Ensure gas type and pressure is correct. Ensure gas line, meter, and/or regulator is sized properly. Bleed all air from gas lines. Verify dip switches are set properly. Ensure igniter is operational. Check igniter wiring harness for damage. Check gas solenoid valves for open or short circuits. Remove burner cover and ensure all burners are properly seated. Remove burner plate and inspect burner surface for condensation or debris.
12	No Flame		Check that the gas is turned on at the water heater, gas meter, or cylinder. Check for obstructions in the flue outlet. Ensure appliance is properly grounded.
		licensed professional only	Ensure gas line, meter, and/or regulator is sized properly. Ensure gas type and pressure is correct. Bleed all air from gas lines. Ensure vent length, vent size and combustion air comply with the requirements stated in the <i>National Fuel Gas Code, ANSI Z223.1/NFPA 54, or the Natural Gas and Propane Installation Code, CSA B149.1.</i> Verify dip switches are set properly. Check power supply for loose connections. Check power supply for proper voltage and voltage drops. Ensure flame rod wire is connected. Check flame rod for carbon build-up. Disconnect and reconnect all wiring harnesses on unit and PC board. Check for DC shorts at components. Check gas solenoid valves for open or short circuits. Remove burner plate and inspect burner surface for condensation or debris.
13	Combustion		Review items listed under codes “05” and “10”.
FE	Flammable Vapors Detected		<ul style="list-style-type: none"> • Leave the area immediately, leaving the exit point open to allow ventilation • Do not touch any electric device (including phone or light switch) • Call emergency personnel from a neighbors phone • Do not try to reset the water heater or light the pilot to any other appliance
	WARNING		When safety personnel have identified the area as safe and all flammable vapors have been removed and eliminated, the units can be reset by unplugging the unit then plugging back in. If “FE” continues to flash after area is determined to be free from flammable vapors, contact a qualified service technician.

Code	Definition		Remedy
14	Thermal Fuse		Check for restrictions in air flow around unit and vent terminal.
		licensed professional only	Check gas type of unit and ensure it matches gas type being used. Ensure dip switches are set to the proper position. Check for foreign materials in combustion chamber and/or exhaust piping. Check heat exchanger for cracks and/or separations. Check heat exchanger surface for hot spots which indicate blockage due to scale build-up. Refer to instructions in manual for flushing heat exchanger. Measure resistance of safety circuit. Ensure high fire and low fire manifold pressure is correct. Check for improper conversion of product.
16	Over Temperature Warning (safety shutdown because unit is too hot)		Check for restrictions in air flow around unit and vent terminal.
		licensed professional only	Check for foreign materials in combustion chamber and/or exhaust piping. Check for clogged heat exchanger. Check that the gas type being used it correct for your unit.
30	FV Sensor		Check sensor wiring for damage. Measure resistance of sensor. Replace sensor
31	Burner Sensor		
32	Heat Exchanger Outgoing Temperature Sensor		Check sensor wiring for damage. Measure resistance of sensor. Clean sensor of scale build-up. Replace sensor.
35	Tank Temperature Sensor		Check sensor wiring for damage. Measure resistance of sensor. Verify that sensor is properly positioned on the tank surface. Replace sensor.
38	CO or FV Sensor		Check sensor wiring for damage. Measure resistance of sensor. Replace sensor.
52	Modulating Solenoid Valve Signal		Check modulating gas solenoid valve wiring harness for loose or damaged terminals. Measure resistance of valve coil.
61	Combustion Fan		Ensure fan will turn freely. Check wiring harness to motor for damaged and/or loose connections. Measure resistance of motor winding.
63	Circulation flow rate has dropped below 1.3 gpm		Check water filter for blockage Check pump operation and wiring Clean Heat Exchanger
71	SV0, SV1, SV2, SV3 Solenoid Valve Circuit Fault		Check wiring harness to all solenoids for damage and/or loose connections. Measure resistance of each solenoid valve coil.
72	Flame Sensing Device		Verify flame rod is touching flame when unit fires. Check all wiring to flame rod. Remove flame rod and check for carbon build-up; clean with sand paper. Check inside burner chamber for any foreign material blocking flame at flame rod. Measure micro amp output of sensor circuit with flame present. Replace flame rod.
73	Burner Sensor Circuit		Check sensor wiring and PCB for damage. Replace sensor.
No code	No hot water, no light or error code on the display		Confirm the water heater is plugged in and 120 volts is available

System Maintenance

The appliance must be inspected annually by a licensed professional. Repairs and maintenance should be performed by a licensed professional. The licensed professional must verify proper operation after servicing.

! WARNING

To protect yourself from harm, before performing maintenance:

- Turn off the electrical power supply by unplugging the power cord or by turning off the electricity at the circuit breaker. (The temperature controller does not control the electrical power.)
- Turn off the gas at the manual gas valve, usually located immediately below the water heater.
- Turn off the incoming water supply. This can be done at the isolation valve immediately below the water heater or by turning off the water supply to the building.

! WARNING

Keep the appliance area clear and free from combustible materials, gasoline, and other flammable vapors and liquids.

Air Screen Inspection, Detection & Cleaning

A. Inspection:

- To maintain optimum performance, periodically inspect the HTT Engine Air Screen.
- If the Air Screen appears to have lint and/or dust build up, follow the cleaning procedure described in step C.
- If the air screen appears damage, contact a qualified service provider for a replacement air filter assembly (Part No. 108000030)

B. Detection: (Controller Flashing 05 or 13)

- Flashing error code 05 or 13 may be an indication that the Air Screen is dirty or restricting air flow to the water heater. Follow the cleaning procedure described in Step C.
- If the controller continues to flash 13 after cleaning the Air Screen, turn off the unit and contact a qualified service provider.

C. Cleaning:

1. Power OFF the water heater
 - Push the round power button located on the right hand side of the controller.
 - Display will go blank when the power is off.
2. Remove the Air Screen Door
 - Slide the door latch to the right
 - Swing the door open and pull the door off the water heater front panel.
3. Clean the Air Screen
 - With mild dish soap and a soft bristle brush, scrub the screen area of the Air Screen Door.

NOTE: Do not operate this water heater if the Air Screen is not in place.

4. Dry the Air Screen
 - With clean water, rinse the soap off the screen.
5. Inspect and Replace the Air Screen
 - With a lint free towel, dry the lint screen
 - Inspect the air screen for any debris that may restrict air flow to the unit.
 - If the screen still appears dirty repeat Step 3
 - Replace the Air Screen Door by aligning the tab at the right of the Air Screen Door with slots on the water heater panel. With the latch slid to the right rotate the door to the closed position and lock the door in place by sliding the latch the left.
6. Power ON the water heater.

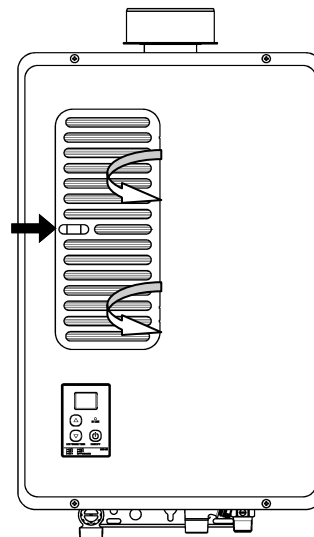

Water Filter Inspection, Detection & Cleaning

A. Inspection:

- To maintain optimum performance, periodically inspect the water filter.
- To clean the water filter follow the cleaning procedure described in Step C.
- If the water filter appears damaged, contact a qualified service provider for a replacement filter (Part No. 107000032)

B. Detection:.....(Controller Flashing 07 or 63)

- **Flashing 07** is an indication that the water filter is dirty or restricting water flow thru the water heater. Although the water heater will continue to operate the cleaning procedure described in Step C should be performed as soon as possible.
- **Flashing 63** is an indication that the water filter is blocked and the appliance can no longer continue to heat water. Follow the cleaning procedure described in Step C.
- If the controller continues to flash the error code after cleaning the water filter, turn off the unit and contact a qualified service provider as this may indicate a pump error.

C. Cleaning:

1. Power OFF the water heater
 - Push the round power button located on the right hand side of the controller.
 - Display will go blank when the power is off.
2. Remove the lower enclosure.
 - Remove the screws around the perimeter of the pump enclosure
 - Remove the enclosure by first pulling away the bottom portion.
3. Drain and Relieve pressure from the system
 - Close the cold water supply valve on the water heater
 - Open any hot water fixture and leave open to allow draining
 - Attach one end of a hose to the drain valve and position the other end of the hose at a near by drain.
4. Remove the filter by turning the thumb screw in a counterclockwise motion.
6. Clean the filter and remove any debris that may reduce water flow.
7. Replace the filter. Turn the thumb screw in clockwise direction until finger tight.
8. Close the drain valve and open the cold water supply valve leaving the hot water fixture open until all air is out of the system
9. Power ON the water heater and set to desired temperature.
10. Close the hot water fixture when finished.

Required Maintenance

Water Heater Tank

Drain a pail of water through the drain valve at least once a year. This will remove excess sediment from the bottom of the tank. This sediment, if allowed to accumulate, will reduce the efficiency and the life of the tank.

Temperature and Pressure-Relief Valve

Manually operate the temperature and pressure-relief valve at least once a year, standing clear of the outlet to avoid being burned. Lift and release the operating lever on the valve to make it operate freely. If, after manually operating the valve, it fails to completely reset itself and continues to discharge water, replace it with a new one.

Venting System Inspection

The venting system must be thoroughly inspected once a year. Check the area where the water heater is located to make sure that there is enough clean combustion and ventilation air. Remove any possible obstructions that would prevent proper air circulation and venting. Check the venting system to make sure that all of the connections are securely fastened, and that all of the joints are properly sealed. If any part of the venting system is damaged, it must be replaced by a qualified service technician. Test the ventilation system to make sure that it is venting properly.

Anode

This water heater is equipped with an anode that is designed to prolong the life of the glass-lined tank. The anode is slowly consumed, protecting the glass-lined tank from corrosion. The anode should be checked every two (2) years. If more than half of the anode has been consumed it should be replaced. Instructions on how to change the anode can be obtained from the manufacturer.

The life expectancy of the anode is reduced where a water softener is introduced to fight hard make this water extremely conductive. In these conditions, the anode is consumed more rapidly and should be verified every year.

In certain water conditions, the anode will react with the water, producing discolored or smelly water. The most common complaint is hot water that smells like rotten eggs. This phenomenon is the result of the reaction between the anode and hydrogen sulfide gas dissolved in the water which occurs frequently in well systems. This problem can usually be eliminated or reduced by changing the anode to a type more suitable for these conditions (aluminum anode) and by chlorinating the water heater and plumbing system (**Maximum chloride level not to exceed 250 mg/L**). If the problem persists, special filtration equipment may be required. Under no circumstances is the anode to be removed from the water heater on a permanent basis. **Removal of the anode will lead to premature failure of the water heater and void the warranty.**

WARNING

Hydrogen gas can be produced in a hot water system that has not been used for a long period of time (generally two (2) weeks or more). **HYDROGEN GAS IS EXTREMELY FLAMMABLE.** It is highly recommended to open the hot water faucet in the kitchen for several minutes before you use any electrical appliances connected to the hot water system, such as a dishwasher or washing machine. If hydrogen gas is present, there will be an unusual sound, such as air escaping through the pipe, as the hot water faucet is opened. **DO NOT** smoke or introduce an open flame near the faucet when it is opened.

Hybrid Tank-Tankless Flush Procedure

Use the following procedure to flush the heat exchanger of lime or scale build up. Damage caused by lime build-up is not covered by the unit's warranty. After flushing, reset any error codes by turning off the power to the unit and turning the power back on.

1. Disconnect electrical power to the water heater.
2. CLOSE the cold water supply valve. Leave the hot water valve and a hot water fixture OPEN to remove pressure from the system.
3. Connect one end of a hose to the drain valve on the tank and direct the other end to a drain. OPEN the drain valve.

NOTICE Do not continue until all water has drained from the tank.

4. Remove the (3/4" NPT) flex fittings ¹★ and ²★ from the assembly. (Note: The tankless engine will still contain approximately 1/2 gallon of water. Prepare a bucket to catch this water.)
5. Connect pump outlet hose (H1) to the (3/4" NPT) in-line filter fitting at the base of the engine.
6. Connect drain hose (H3) to the (3/4" NPT) supply fitting at the base of the engine.
7. Pour approximately 4 gallons of virgin, food grade, white vinegar or citric acid into a pail.
8. Place the drain hose (H3) and the hose (H2) to the pump inlet into the cleaning solution.
9. Operate the pump and allow the cleaning solution to circulate through the water heater for at least 45 minutes.
10. Turn off pump.
11. Rinse the cleaning solution from the water heater as follows:

- a. Disconnect hose (H1) from the engine.
- b. Connect a cold water supply fitting and hose to the IN-LINE FILTER fitting at the base of the engine (3/4" NPT).
- c. Move drain hose (H3) from the pail to a drain.
- d. Open cold water supply and allow water to flow through the engine for 5 minutes.
- e. Remove, clean and replace the in-line filter.
- f. Remove Hose (H3) and the cold water supply hose from the base of the engine.
- g. Re-Install the (3/4" NPT) flex fittings ¹★ and ²★ to the assembly.
- h. CLOSE THE DRAIN VALVE
- i. Open the cold water supply valve until water flows from the hot water fixture
- j. Close the cold water supply valve.
- k. Connect power to the water heater and turn the temperature down to set point 1.

12. Open the cold water supply valve until water flows from the hot water fixture (See Step 2).

13. Close the hot water fixture and inspect the appliance and plumbing for leaks.

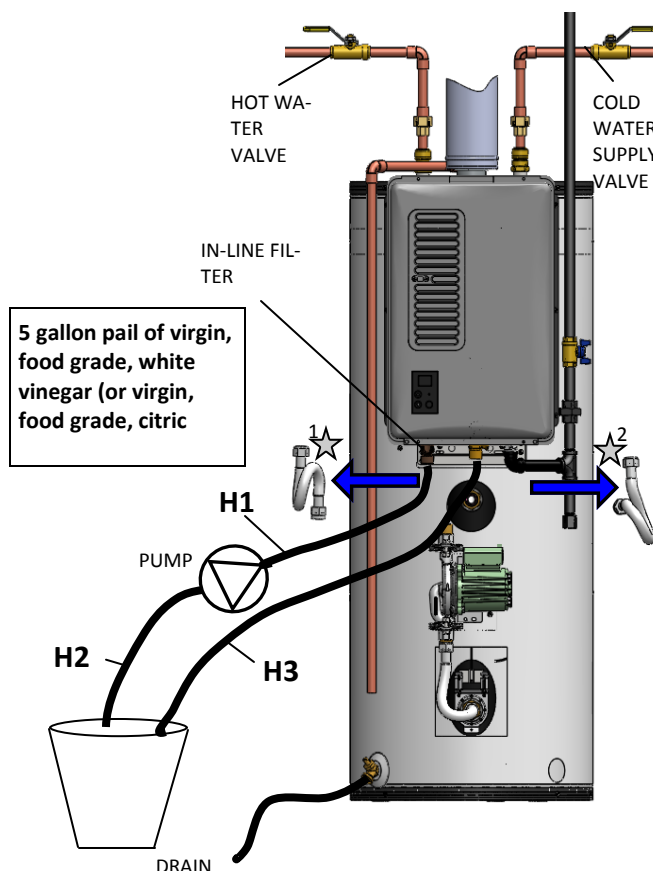

Consumer Support

Warranty Information

The installer is responsible for your water heater's correct installation.

Please complete the information below to keep for your records:

Purchased from: _____

Address: _____ **Phone:** _____

Date of Purchase: _____ **Date of Installation:** _____

Model No.: _____

Serial No.: _____

Installed by: _____ **Installer's License No.:** _____

Limited Warranty for Hybrid Tank - Tankless

What is covered?

The Rinnai Standard Limited Warranty covers any defects in materials or workmanship when the product is installed and operated according to Rinnai written installation instructions, subject to the terms within this Limited Warranty document. This Limited Warranty applies only to products that are installed correctly. Improper installation may void this Limited Warranty. Rinnai strongly suggests that you use a licensed professional who has attended a Rinnai installation training class before installing this water heater. This Limited Warranty coverage as set out in the table below extends to the original purchaser and subsequent owners, but only while the product remains at the site of the original installation. This Limited Warranty only extends to the first / original installation of the product and terminates if the product is moved or reinstalled at a new location.

How long does warranty coverage last?

Item	Period of Coverage (from date of purchase)		
	Single Family Residential Applications Domestic Hot Water Only	Commercial Applications Domestic Hot Water Only	Combination Domestic Hot Water / Space Heating and All Other Applications [3]
Heat Exchanger	10 years [1]	5 years [2]	3 years
Tank	6 years [1]	1 year	1 year
All Other Parts and Components	3 years	3 years	3 years
Reasonable Labor		1 year	

[1] For residential applications the period of coverage is reduced to 3 years on the heat exchanger and 1 year on the tank from date of purchase when used as a recirculating water heater within a hot water recirculation loop, where the water heater is in series with a recirculation system and all recirculating water flows through the water heater, and where an aquastat / thermostat, timer, or an on-demand recirculation system is not incorporated. A system that incorporates a continuous recirculation due to timer settings, excessive heat loss of the loop or aquastat / thermostat setting will be treated as a continuous recirculation system and have a reduced warranty of 3 years on the heat exchanger and 1 year on the tank.

On-demand recirculation is defined as a hot water recirculating loop or system that utilizes existing hot and cold lines or a dedicated return line, and only activates when domestic hot water is used.

[2] Commercial applications incorporating any type of recirculation has a reduced warranty period of 3 years on the heat exchanger.

[3] Domestic hot water must be heated directly within the water heater. When combined with domestic hot water production the water heater may be connected to provide space heating either directly or indirectly for distributing heated fluid to either a fan coil or similar appliance for space heating purposes.

What will Rinnai do?

Rinnai will repair or replace the covered product or any part or component that is defective in materials or workmanship as set forth in the above table. Rinnai will pay reasonable labor charges associated with the repair or replacement of any such part or component during the term of the labor warranty period. All repair parts must be genuine Rinnai parts. All repairs or replacements must be performed by a licensed professional that is properly trained, state qualified or licensed to do the type of repair.

Replacement of the product may be authorized by Rinnai only at its sole discretion. Rinnai does not authorize any person or company to assume for it any obligation or liability in connection with the replacement of the product. If Rinnai determines that repair of a product is not possible, Rinnai may replace the product with a comparable product at Rinnai's sole discretion. If a component or product returned to Rinnai is found to be free of defects in material or workmanship, or damaged by improper installation or damaged during return shipping, the warranty claim for product, parts and labor may be denied.

How do I get service?

You must contact a licensed professional for the repair of a product under this Limited Warranty. For the name of a licensed professional please contact your place of purchase, visit the Rinnai website (www.rinnai.us), call Rinnai at 1-800-621-9419 or write to Rinnai at 103 International Drive, Peachtree City, Georgia 30269.

Proof of purchase is required to obtain warranty service. You may show proof of purchase with a dated sales receipt, or by registering within 30 days of purchasing the product. To register your water heater, please visit (www.rinnai.us/product-registration). For those without internet access, please call 1-866-RINNAI1 (746-6241). Receipt of Registration by Rinnai will constitute proof-of-purchase for this product. Registration of product installed in new home construction may be verified with a copy of the closing papers provided by the initial home buyer. However, Registration is not necessary in order to validate this Limited Warranty.

What is not covered?

This Warranty does not cover any failures or operating difficulties due to the following:

- accident, abuse, or misuse
- alteration of the product or any component part
- misapplication of this product
- improper installation
 - ◇ product being installed in a corrosive environment
 - ◇ condensate damage
 - ◇ improper venting
 - ◇ incorrect gas type
 - ◇ incorrect gas or water pressure
 - ◇ absence of a drain pan under the appliance
- water quality
- Improper maintenance (such as but not limited to scale build-up, freeze damage, or vent blockage)
- incorrect sizing
- any other cause not due to defects in materials or workmanship
- problems or damage due to fires, flooding, electrical surges, freezing or any acts of God.
- force majeure

There is no warranty coverage on product installed in a closed loop application, commonly associated with space heating only applications.

This Limited Warranty does not apply to any product whose serial number or manufacture date has been defaced.

This Limited Warranty does not cover any product used in an application that uses chemically treated water such as a pool or spa heater.

Limitation on warranties

No one is authorized to make any other warranties on behalf of Rinnai America Corporation. Except as expressly provided herein, there are no other warranties, expressed or implied, including, but not limited to warranties of merchantability or fitness for a particular purpose, which extend beyond the description of the warranty herein. Any implied warranties of merchantability and fitness arising under state law are limited in duration to the period of coverage provided by this Limited Warranty, unless the period provided by state law is less. Some states do not allow limitations on how long an implied Limited Warranty lasts, so the above limitation may not apply to you.

Rinnai shall not be liable for indirect, incidental, special, consequential or other similar damages that may arise, including lost profits, damage to person or property, loss of use, inconvenience, or liability arising from improper installation, service or use. Some states do not allow the exclusion or limitation of incidental or consequential damages, so the above limitation may not apply to you.

This Limited Warranty gives you specific legal rights, and you may also have other rights which vary from state to state.

For more information regarding product warranty please visit: www.rinnai.us/warranty

A tradition of TRUE RELIABILITY.

For nearly 100 years, we at Rinnai have been fiercely committed to delivering nothing less than our absolute best at every touch point.

To us, that means more than manufacturing products—it's about inspiring confidence in our customers. Confidence in the comfort our solutions give. And in the support we provide.



Learn more about our high-performance Tankless Water Heaters, Boilers and Direct Vent Wall Furnaces at www.rinnai.us.

Rinnai.

Rinnai America Corporation • 103 International Drive, Peachtree City, GA 30269
Toll-Free: 1-800-621-9419 • Phone: 678-829-1700 • www.rinnai.us

©2013 Rinnai America Corporation. Rinnai is continually updating and improving products; therefore, specifications are subject to change without prior notice. Local, state, provincial and federal and national fuel gas codes must be adhered to prior to and upon installation.