



INSTALLATION AND OPERATION MANUAL

Demand Duo™ 2

Commercial Hybrid Water Heating System



MODEL

CHS398100CU

WARNING

If the information in these instructions is not followed exactly, a fire or explosion may result causing property damage, personal injury, or death.

- Do not store or use gasoline or other flammable vapors and liquids in the vicinity of this or any other appliance.
- WHAT TO DO IF YOU SMELL GAS
 - Do not try to light any appliance.
 - Do not touch any electrical switch; do not use any phone in your building.
 - Immediately call your gas supplier from a neighbor's phone. Follow the gas supplier's instructions.
 - If you cannot reach your gas supplier, call the fire department.
- Installation and service must be performed by a trained and qualified professional, service agency or the gas supplier.

Contents

| | | | |
|---|-----------|--|-----------|
| 1. Welcome | 3 | 6. Maintenance | 29 |
| 2. Safety | 4 | Storage Tank Anodes | 29 |
| Safety Symbols..... | 4 | Storage Tank | 29 |
| Safety Precautions | 5 | 7. Appendices | 30 |
| 3. About | 6 | Piping Diagram for Basic Installations | 30 |
| Components..... | 6 | Controller Diagnostics..... | 31 |
| Specifications | 7 | Replacement Parts..... | 33 |
| Recovery Capabilities..... | 7 | Limited Warranty for SE+ Series Models | 35 |
| Dimensions..... | 8 | Notes..... | 37 |
| 4. Installation Preparation | 9 | | |
| Installation Guidelines | 9 | | |
| Installation Illustrations | 10 | | |
| Confirm Shipping Contents | 11 | | |
| Gather Tools and Materials | 12 | | |
| Determine Location and Clearances..... | 12 | | |
| 5. Installation Instructions | 14 | | |
| Step 1: Transport | 14 | | |
| Step 2: Secure for Earthquake | 14 | | |
| Step 3: Position Tank and Connect Water | 15 | | |
| Step 4: Install Rack Frame Legs..... | 16 | | |
| Step 5: Position Rack..... | 17 | | |
| Step 6: Install Water Flex Lines..... | 18 | | |
| Step 7: Secure Rack..... | 19 | | |
| Step 8: Install Vent System | 20 | | |
| Step 9: Install Relief Valve Lines | 20 | | |
| Step 10: Fill System with Water | 22 | | |
| Step 11: Connect Condensate Drain Line | 23 | | |
| Step 12: Connect Gas Supply | 24 | | |
| Step 13: Connect Communication Cable | 25 | | |
| Step 14: Connect Power Supply..... | 26 | | |
| Post-Installation Checklist..... | 28 | | |

1 Welcome

Thank you for purchasing Rinnai's Demand Duo™ 2 Commercial Hybrid Water Heating System.

This manual provides information on the installation, operation, and maintenance of the system. Read this manual completely before installing or operating the system.

This manual is a supplement to the Installation and Operation Manual for Commercial CU199 Condensing Tankless Water Heaters; refer to the CU199 manual for complete water heater information.

To The Installer

- A trained and qualified professional must install the system, inspect it, and leak test it before use. The warranty will be voided due to any improper installation.
- The trained and qualified professional should have skills such as:
 - Gas line sizing
 - Connecting gas lines, water lines, valves, and electricity
 - Knowledge of applicable national, state, and local codes
 - Installing venting through a wall or roof
 - Training in installation of tankless water heaters. Training on Rinnai Tankless Water Heaters is accessible at www.trainingevents.rinnai.us.
- Read all instructions in this manual before installing the system. The system must be installed according to the exact instructions in this manual.
- Proper installation is the responsibility of the installer.
- When installation is complete, leave this manual with the system or give the manual directly to the consumer.

If You Need Service

Contact your local dealer/distributor or call Rinnai Customer Care at:

1-800-621-9419

Please have your full serial number or model number available for product- or service-related issues.

To The Consumer

- You must read the entire manual to properly operate the system and to have regular maintenance performed.
- Keep this manual for future reference.
- As when using any appliance generating heat, there are certain safety precautions you should follow. See the **Safety Precautions** section for detailed safety precautions.
- Be sure your water heater is installed by a trained and qualified professional.
- If installing in the state of Massachusetts, you must read the **Massachusetts State Gas Regulations** section in the Installation and Operation Manual for Commercial CU199 Condensing Tankless Water Heaters (supplied with the Demand Duo™ 2 system).

For Your Records

Dealer Name: _____

Dealer Phone #: _____

Purchase Date: _____

Demand Duo™ 2 Serial #: _____

Rack Serial #: _____



← Demand Duo™ 2 Serial # and Rack Serial # located on side of rack frame leg.

2 Safety

WARNING

- If the information in these instructions is not followed exactly, a fire or explosion may result causing property damage, personal injury, or death.
- Do not store or use gasoline or other flammable vapors and liquids in the vicinity of this or any other appliance.
- WHAT TO DO IF YOU SMELL GAS:
 - Do not try to light any appliance.
 - Do not touch any electrical switch; do not use any phone in your building.
 - Immediately call your gas supplier from a neighbor's phone. Follow the gas supplier's instructions.
 - If you cannot reach your gas supplier, call the fire department.
- Installation and service must be performed by a trained and qualified professional, service agency or the gas supplier.
- The warning signs in this manual are here to prevent injury to you and others. Please follow them explicitly.

Safety Symbols

This manual contains the following important safety symbols. Always read and obey all safety messages.



Safety alert symbol. Alerts you to potential hazards that can kill or hurt you and others.



Indicates a potentially hazardous situation which, if not avoided, could result in personal injury or death.



Indicates an imminently hazardous situation which, if not avoided, will result in personal injury or death.



Indicates a potentially hazardous situation which, if not avoided, could result in minor or moderate injury. It may also be used to alert against unsafe practices.

Safety Precautions

For proper installation, operation and safety, it is important to follow the instructions and adhere to the safety precautions shown throughout this manual. The following precautions apply to the installer and consumer.



WARNING DO NOT adjust the internal gas valve. The design is such that adjustment is not required. Warranty will be voided if the internal gas valve is adjusted.

- Before operating, smell all around the appliance area for gas. Be sure to smell next to the floor because some gas is heavier than air and will settle on the floor.
- Keep the area around the appliance clear and free from combustible materials, gasoline, and other flammable vapors and liquids.
- Combustible construction refers to adjacent walls and ceiling and should not be confused with combustible or flammable products and materials. Combustible and/or flammable products and materials should never be stored in the vicinity of this or any gas appliance.
- Always check the water temperature before entering a shower or bath.
- To protect yourself from harm, before performing maintenance:
 - Turn off the electrical power supply by unplugging the power cord or by turning off the electricity at the circuit breaker. (The temperature controller does not control the electrical power.)
 - Turn off the gas at the manual gas control valve.
 - Turn off the incoming water supply.
 - Use only your hand to turn the manual gas control valve. Never use tools. If the manual gas control valve will not turn by hand, do not try to repair it; call a trained and qualified professional. Force or attempted repair may result in a fire or explosion.
- Do not use this appliance if any part has been under water. Immediately call a trained and qualified professional to inspect the appliance and to replace any part of the control system and any manual gas control valve which has been under water.
- Do not use substitute materials. Use only parts certified for the appliance.
- Should overheating occur or the gas supply fail to shut off, turn off the manual gas control valve to the appliance.
- Only trained and qualified professionals are permitted to adjust parameter settings.
- Do not use an extension cord or adapter plug with this appliance.
- Any alteration to the appliance or its controls can be dangerous and will void the warranty.
- Proper venting is required for the safe operation of this appliance.
- Flammable liquids such as cleaning solvents, aerosols, paint thinners, adhesives, gasoline and propane must be handled and stored with extreme care. These flammable liquids emit flammable vapors and when exposed to an ignition source can result in a fire hazard or explosion. Flammable liquids should not be used or stored in the vicinity of this or any other gas appliance.
- DO NOT operate the water heater without the front panel installed. The front panel should only be removed for service/maintenance or replacing internal components.
- BURN HAZARD. Hot exhaust and vent may cause serious burns. Keep away from the water heater. Keep small children and animals away from the water heater.
- Hot water outlet pipes leaving the water heater can be hot to touch.
- Do not store or use gasoline or other flammable vapors and liquids in the vicinity of this or any other appliance.
- Install the vent system per local and national codes.
- Do not install this water heater above 10,200 ft (3,109 m).
- Do not obstruct combustion air to the water heater.
- Failure to properly vent this appliance can result in death, personal injury and/or property damage.
- Rinnai recommends that every home have a carbon monoxide (CO) alarm inside or directly outside each bedroom or sleeping area. Check batteries monthly and replace them annually.
- California law requires the following Proposition 65 warning to be provided:



WARNING

This product can expose you to chemicals including lead, lead compounds and carbon disulfide which are known to the State of California to cause cancer, birth defects or other reproductive harm. For more information, visit www.P65Warnings.ca.gov.

3 About

The Demand Duo™ 2 Commercial Hybrid Water Heating System pairs a 119-gallon storage tank with two pre-installed Rinnai SENSEI™ Condensing Tankless Water Heaters.

Components

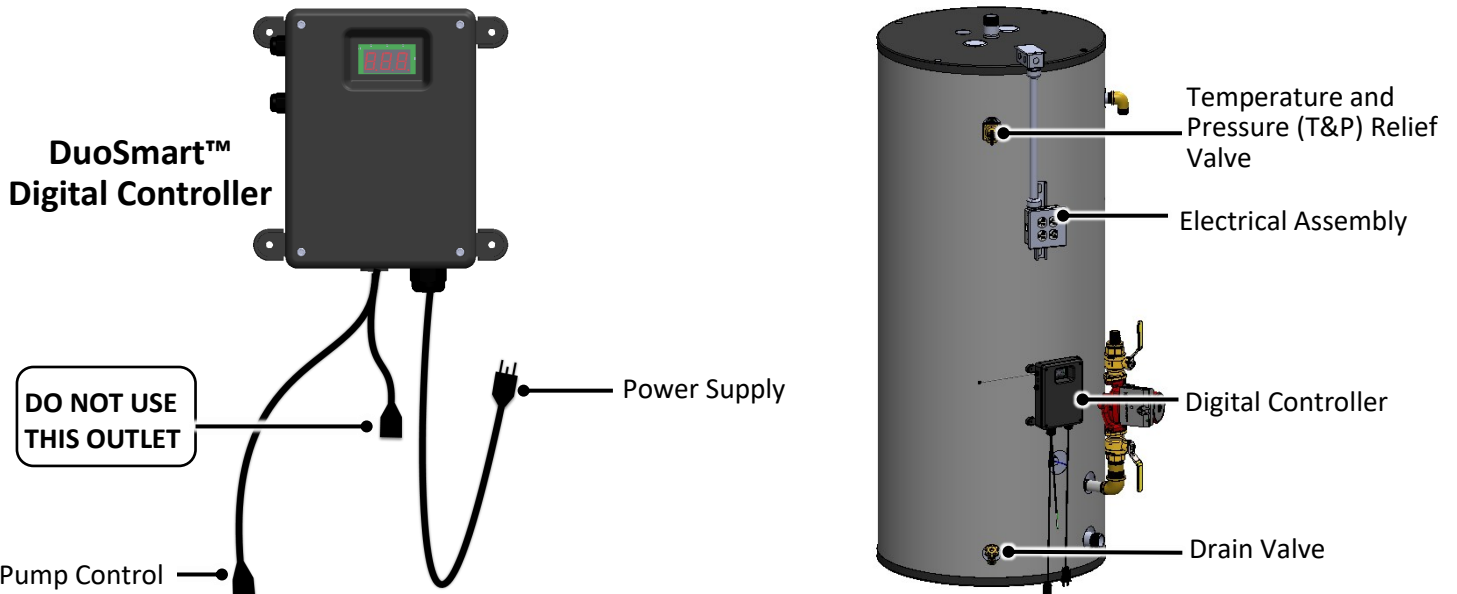
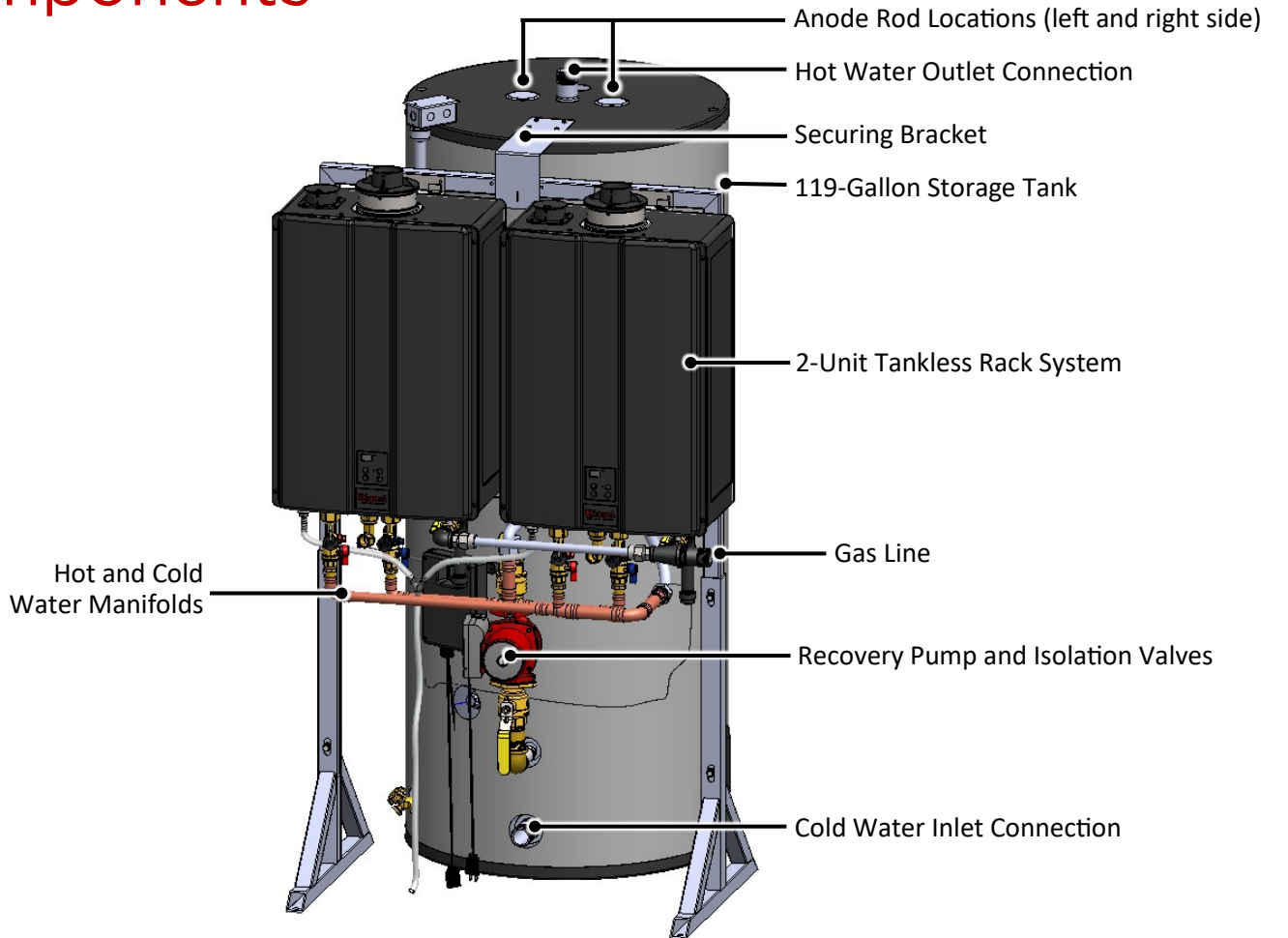

Specifications

| | |
|--|---|
| Model Number | CHS398100CU |
| Dimensions (Assembled) in. (mm) | w x h x d: 38.81 x 69.60 x 40.96 (985.8 x 1,767.8 x 1,040.4) |
| Weight | Rack (with 2 Tankless Water Heaters): 220 lbs (100 kg); Tank: 310 lbs (141 kg) Complete System: 530 lbs (240 kg) |
| Installation Type | Internal (Indoor) Commercial Applications |
| Category and Ignition System | Category IV, Direct Electronic Ignition |
| Gas Consumption Btu/h (kW/h) | Minimum: 30,400 (9) Maximum: 398,000 (116.6) |
| Water Supply Pressure | 150 PSI (Maximum) |
| Thermal Efficiency (CU199) | 97% |
| Temperature Setting | 98°F (37°C) to 185°F (85°C) |
| Tank Volume | 119 Gallons (450 Liters) |
| First Hour Delivery Rating* | 543 Gallons (2,055 Liters) |
| Sound Level (Single unit) | 49 dB |
| Electrical Data (CU199 Tankless Water Heater) | Normal: 265 W, Standby: 44 W, Freeze Protection: 148 W, Max Current: 5.5 A |
| | Fuse: Tankless Water Heater Engine: 10 Amps, Controller: 10 Amps |
| Gas Supply Pressure** | Natural: 3.5 - 10.5 in. w.c. Propane: 8.0 - 13.5 in. w.c. |
| By-Pass Flow Control | Electronic |
| Connections | Gas Supply Inlet: 1-1/2 in. MNPT Hot Water Outlet: 1-1/2 in. MNPT Cold Water Inlet: 1-1/2 in. MNPT |
| Electric Connections | Appliance: AC 120 Volts, 60Hz. Integrated Temperature Controller: DC 12 Volts (Digital) |
| Water Flow Control | Water Flow Sensor, Electronic Water Control and Bypass Control |
| Water Temperature Control | Simulation Feed Forward and Feedback |
| Recovery | 459 GPH @ 100° ΔT |
| High Altitude Approved | Up to 10,200 Ft (3,109 M) |
| Complies with South Coast Air Quality Management District 14 ng/J or 20 ppm NOx Emission Levels (CU199i) | Yes |
| Ultra Low NOx | Yes |
| Certifications | AHRI, ANSI Z21.10.3, CSA 4.3 and ENERGY STAR® Certified (CU199i) |
| Controller | MCC-91-2US |
| Recirculation Pump | Grundfos UPS 26-150 (SJF); 3 Speed |
| Venting Material | Polypropylene, PVC |
| Venting Options | Concentric Polypropylene, Twin Pipe, or Common Vent Polypropylene/PVC/CPVC. Vent lengths up to 150 ft. |
| Wi-Fi Ready | Yes |

* First Hour Delivery Rating is a theoretical calculation based on 70% usable tank capacity.

Tank Capacity x .70 + (recovery) = First Hour Delivery Rating

** Maximum gas supply pressure must not exceed the value specified by the manufacturer.

Recovery Capabilities

| U.S. Gallons / HR Liters / HR at Temperature Rise Indicated | | | | | | | | | | | | | |
|---|------------|-------|-------|-------|-------|-------|-------|-------|-------|-------|-------|-------|-------|
| Tank Capacity | °F | 30 | 40 | 50 | 60 | 70 | 80 | 90 | 100 | 110 | 120 | 130 | 140 |
| | °C | 17 | 22 | 28 | 33 | 39 | 44 | 50 | 56 | 61 | 67 | 72 | 78 |
| 119 U.S. Gal. | GPH | 1,528 | 1,147 | 917 | 764 | 655 | 573 | 510 | 459 | 417 | 382 | 353 | 328 |
| 450 Liters | LPH | 5,784 | 4,342 | 3,471 | 2,892 | 2,479 | 2,169 | 1,931 | 1,738 | 1,579 | 1,446 | 1,336 | 1,242 |

Dimensions

LEFT

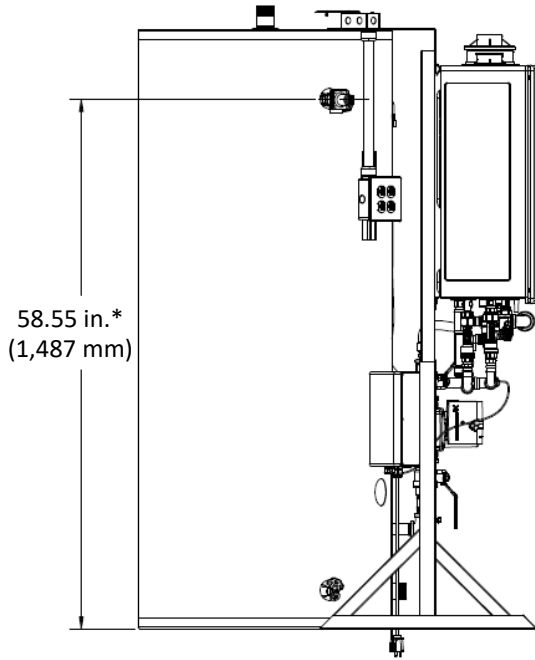

*Temperature and Pressure Relief Valve

RIGHT

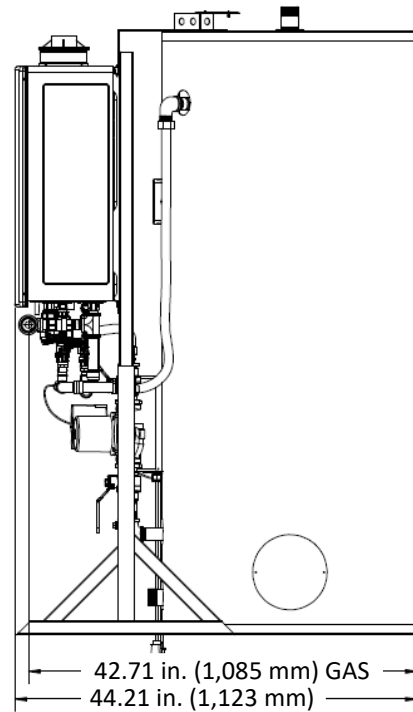

TOP

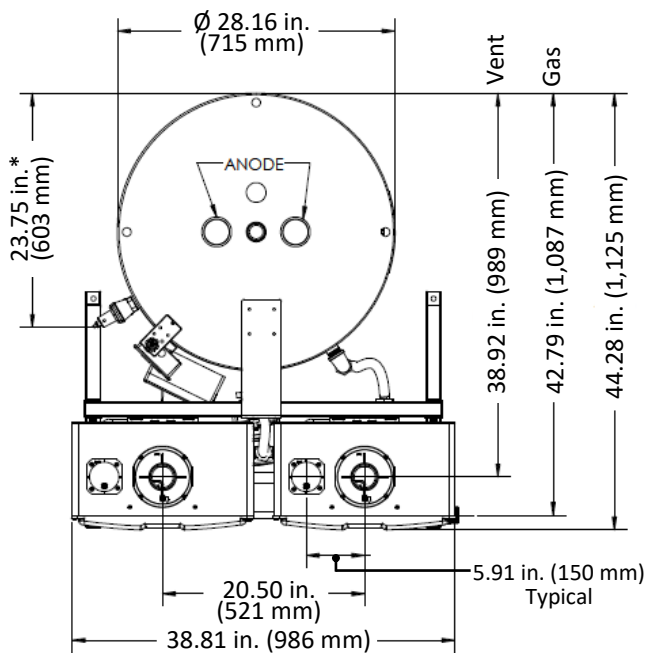

* Temperature and Pressure Relief Valve

FRONT

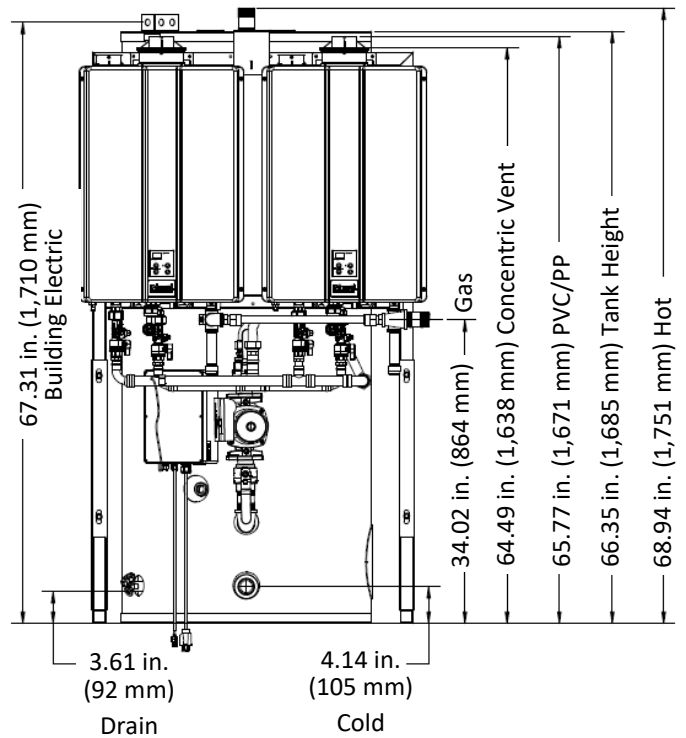

4 Installation Preparation

THIS SECTION IS INTENDED FOR THE INSTALLER

Installer qualifications: A trained and qualified professional must install the appliance, inspect it, and leak test the Demand Duo™ 2 before use. The warranty will be voided due to any improper installation. The trained and qualified professional should have skills such as: Gas sizing; Connecting gas lines, water lines, valves, and electricity; Knowledge of applicable national, state, and local codes; Installing venting through a wall or roof; and training in installation of tankless water heaters. Training for Rinnai Tankless Water Heaters is accessible online at www.trainingevents.rinnai.us.

Installation Guidelines

When installing the Demand Duo™ 2, follow these guidelines:

- This water heater is suitable for combination water heating and space heating and not suitable for space heating applications only.
- The installation must conform with local codes or, in the absence of local codes, with the *National Fuel Gas Code, ANSI Z223.1/NFPA 54*, or the *Natural Gas and Propane Installation Code, CSA B149.1*.
- The appliance, when installed, must be electrically grounded in accordance with local codes or, in the absence of local codes, with the *National Electrical Code, ANSI/NFPA 70*, or the *Canadian Electrical Code, CSA C22.1*.
- The appliance and its main gas valve must be disconnected from the gas supply piping system during any pressure testing of that system at test pressures in excess of 1/2 psi (3.5 kPa) (13.84 in W.C.). For system testing at pressures less than or equal to 1/2 psi (3.5 kPa) (13.84 in W.C.) the appliance must be isolated from the gas supply piping by closing its individual manual shutoff valve.
- You must follow the installation instructions and those in the venting section for adequate combustion air and exhaust.
- If a water heater is installed in a closed water supply system, such as one having a backflow preventer in the cold water supply line, means shall be provided to control thermal expansion. Contact the water supplier or local plumbing inspector on how to control thermal expansion.
- Should overheating occur or the gas supply fail to shut off, turn off the manual gas control valve to the appliance.
- Combustion air must be free of chemicals, such as chlorine or bleach, that produce fumes. These fumes can damage components and reduce the life of your appliance.

DO NOT

- DO NOT install the Demand Duo™ 2 outdoors.
- DO NOT install the Demand Duo™ 2 in an area where water leakage of the unit or connections will result in damage to the area adjacent to the system or to lower floors of the structure. When such locations cannot be avoided, it is recommended that a suitable drain pan, adequately drained, be installed under the water heaters. The pan must not restrict combustion air flow.
- DO NOT install the Demand Duo™ 2 in an area with negative air pressure, where the pressure inside your home is lower than the pressure outside.
- DO NOT obstruct the flow of combustion and ventilation air.
- DO NOT use the Demand Duo™ 2 in an application such as a pool or spa heater that uses chemically treated water. The Demand Duo™ 2 is suitable for filling large or whirlpool spa tubs with potable water.
- DO NOT use substitute parts that are not authorized for this system.
- DO NOT connect power to the Demand Duo™ 2 prior to completing installation and the system has been filled with water.

Installation Illustrations

Typical Installation

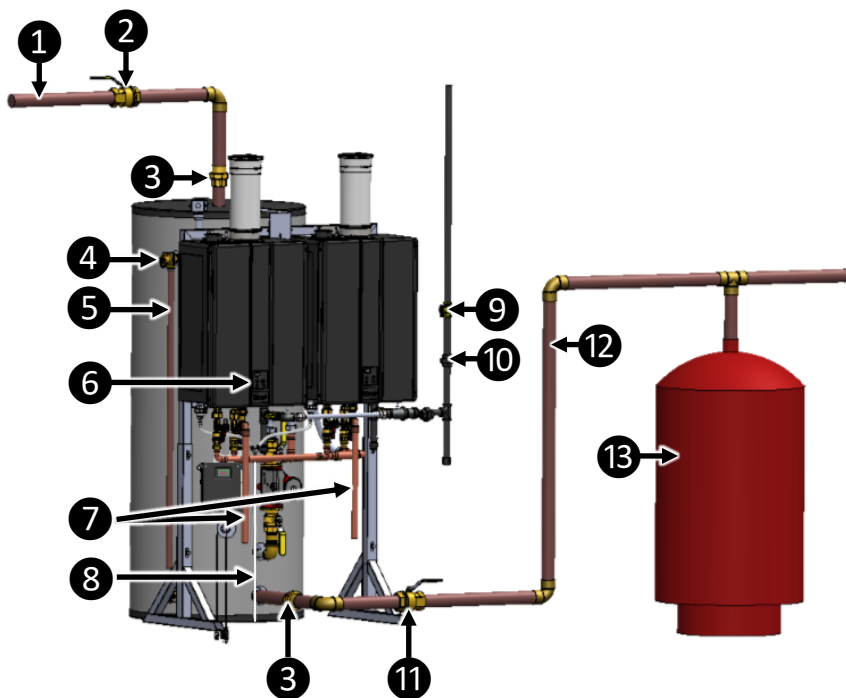

| # | Item | Field Supplied |
|----|---|----------------|
| 1 | Hot Water Outlet | ✓ |
| 2 | Hot Water Outlet Shut-Off Valve | ✓ |
| 3 | Cold and Hot Unions | ✓ |
| 4 | Temperature-Pressure Relief Valve | |
| 5 | Temperature-Pressure Relief Valve Discharge Pipe <i>(do not cap, plug or reduce)</i> | ✓ |
| 6 | Controller | |
| 7 | Pressure Relief Valve Discharge Pipes <i>(do not cap, plug, or reduce)</i> | ✓ |
| 8 | Condensate Discharge Pipe <i>(must include an air gap)</i> | |
| 9 | Gas Control Valve | ✓ |
| 10 | Gas Union | ✓ |
| 11 | Cold Water Supply Shut-Off Valve | ✓ |
| 12 | Cold Water Supply | ✓ |
| 13 | Thermal Expansion Tank | ✓ |
| 14 | Non-Tempered Supply Line | ✓ |
| 15 | Thermostatic Mixing Valve | ✓ |
| 16 | Non-Tempered Return Line | ✓ |

Installation with Mixing Valve

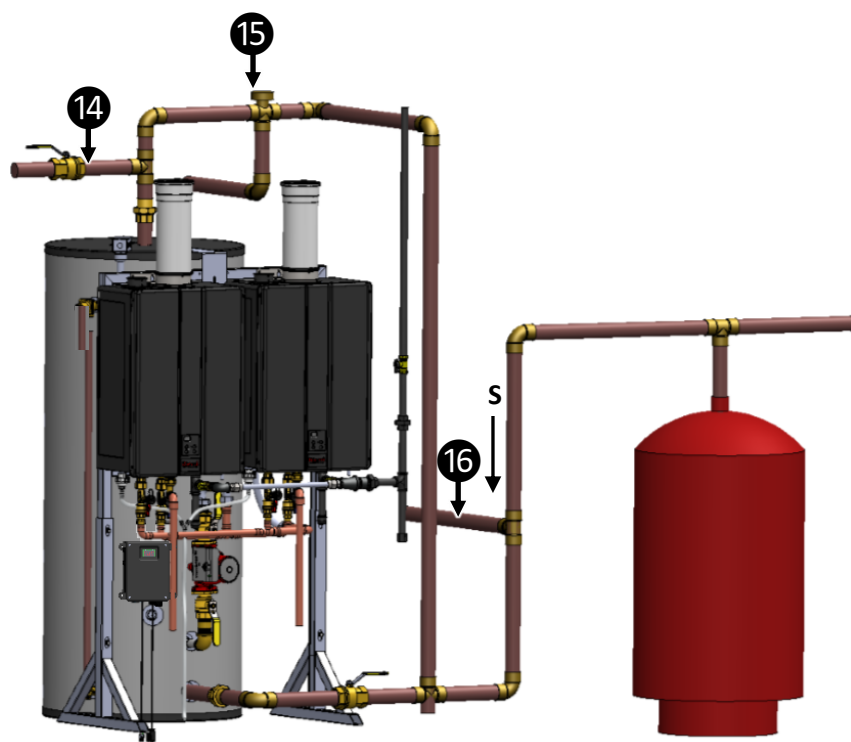

➔ IMPORTANT

Cold water line and expansion tank locations are altered for illustrative purposes.

Confirm Shipping Contents

The Demand Duo™ 2 Commercial Hybrid Water Heating System is packaged and shipped in two separate shipping boxes. Carefully unpack the shipping boxes and verify the following contents are included.

If any items are damaged or missing, contact your local dealer/distributor or call Rinnai Customer Care at 1-800-621-9419. Do not attempt to use any item that appears damaged.

Shipping Box 1

- 119-Gallon Storage Tank
- Recovery Pump
- Pump Isolation Valves
- Electric Assembly
- DuoSmart™ Digital Controller

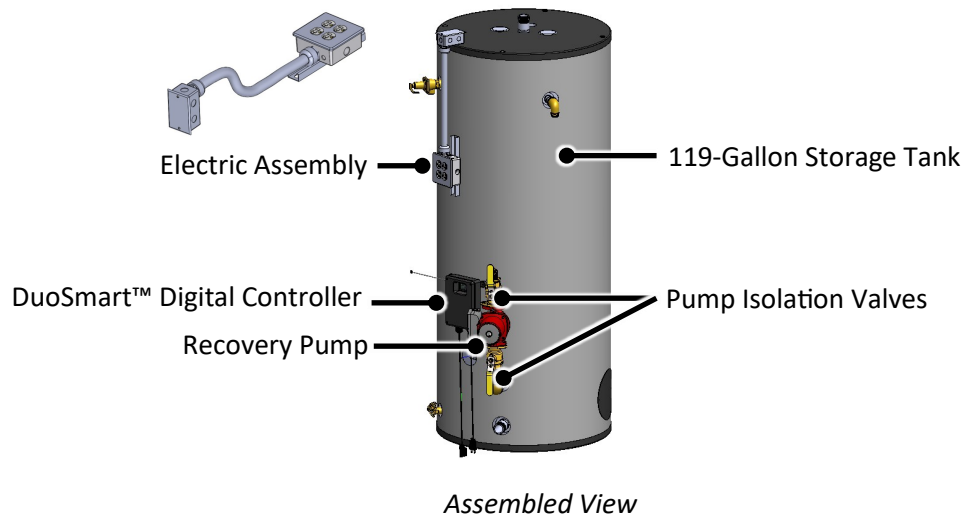

Shipping Box 2

- Rack System with two (2) pre-installed Rinnai Tankless Water Heaters
- Frame Legs (Qty 2)
- Water Flex Lines (Qty 2)
 - 12 in. (305 mm)
 - 36 in. (914 mm)
- 5/16 in.-18 Bolts (Qty 4) (*not shown in image*)
- Securing Bracket
- Documentation:
 - Demand Duo™ 2 Commercial Hybrid Water Heating System Installation and Operation Manual (this manual)
 - Tankless Water Heater Installation and Operation Manual

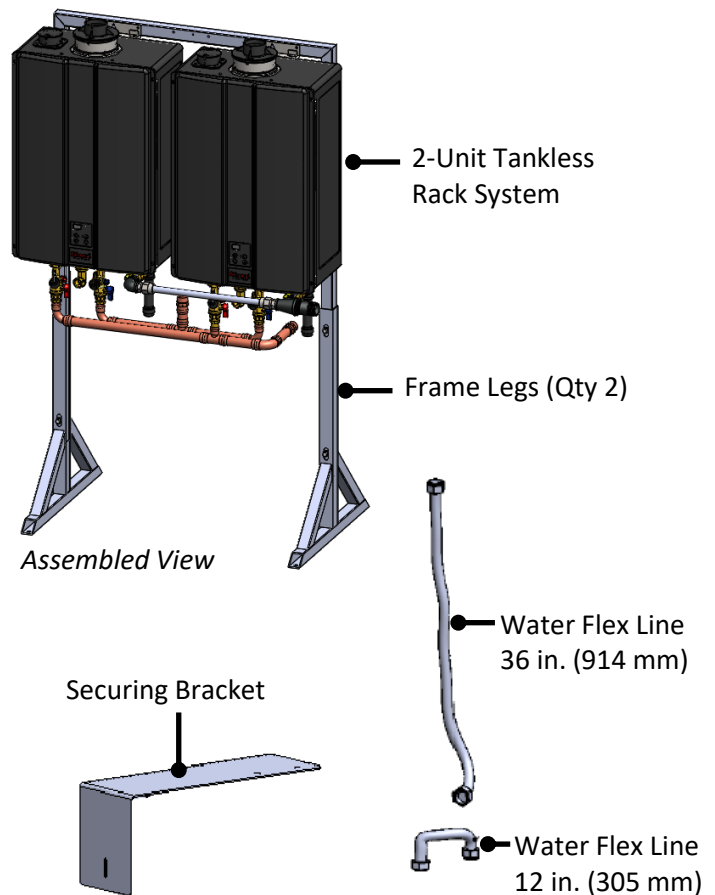

WARNING To avoid danger of suffocation, keep plastic bags away from babies, small children and pets. Do not use these bags in cribs, beds, carriages, or playpens. The bags are not a toy.

Gather Tools and Materials (Field-Supplied)

Gather the recommended tools and materials before starting installation.

Items Needed

- Pipe wrenches (x2)
- Phillips Head screwdriver
- Adjustable pliers
- Wire cutters
- Hoisting straps (able to support approximately 220 lb/100 kg)
- Gloves
- Safety glasses
- Level
- Soap or gas leak detector solution
- Approved venting
- Teflon tape (recommended) or pipe compound
- Pipe insulation

Items You May Need

- Hammer drill with concrete bits
- Saw
- Threading machine with heads and oiler
- Core drill with diamond head
- Torch set
- Copper tubing cutter
- Steel pipe cutter
- Heat tape
- 5/8 in. ID PVC flexible tubing
- Electrical wire
- Concrete wall anchors
- Optional pipe cover
- PVC glue/cement and primer
- 2 conductor 22 AWG wire for controller
- Single gang electrical box
- Wire nuts
- Unions and drain valves
- Drain pan
- Earthquake strap

Determine Location and Clearances

When selecting an installation location, you must ensure that clearances will be met and that the vent length will be within required limits. Consider the installation environment, water quality, and need for freeze protection. Requirements for the gas line, water lines, electrical connection, and condensate disposal can be found in their respective sections in this manual.

For vent termination clearances, refer to the Tankless Water Heater Installation and Operation Manual supplied with the Demand Duo™ 2 system.

Water Quality Guidelines

This section provides information on the importance of water quality to the Rinnai Tankless Water Heater. The information is intended to serve as general guidelines only and is not a complete list of water quality guidelines.

Consideration of care for your water heater should include evaluation of water quality. The water must be potable, free of corrosive chemicals, sand, dirt, or other contaminants. It is up to the installer to ensure the water does not contain corrosive chemicals or elements that can affect or damage the Rinnai Tankless Water Heater. Water that contains chemicals exceeding the levels below can damage the Rinnai Tankless Water Heater. Replacement of components due to water quality damage is not covered by the warranty.

| Contaminant | Maximum Level |
|---|-----------------|
| Total Hardness | Up to 200 mg/L |
| Aluminum * | Up to 0.2 mg/L |
| Chlorides * | Up to 250 mg/L |
| Copper * | Up to 1.0 mg/L |
| Dissolved Carbon Dioxide (CO ₂) | Up to 15.0 mg/L |
| Iron * | Up to 0.3 mg/L |
| Manganese * | Up to 0.05 mg/L |
| pH * | 6.5 to 8.5 |
| TDS (Total Dissolved Solids) * | Up to 500 mg/L |
| Zinc * | Up to 5 mg/L |

* Source: Part 143 National Secondary Drinking Water Regulations

If you install the Demand Duo™ 2 in an area that is known to have hard water or that causes scale build-up, the water must be treated and may require a more frequent flushing schedule.

This water heater includes a service indicator (Service Soon, 55). When selected in the parameter settings, an 55 code will display on the controller indicating that it is time to flush and service the water heater. Scale build-up is caused by hard water and can be accelerated if the water heater is set at a temperature above 120°F.

Rinnai offers Southeastern Filtration’s “ScaleCutter Water Conditioning System” that offers superior lime scale prevention and corrosion control by feeding a blend of control compounds into the cold water supply.

Environment

Air surrounding the water heater, venting, and vent termination(s) is used for combustion and must be free of any compounds that cause corrosion of internal components. These include corrosive compounds that are found in aerosol sprays, detergents, bleaches, cleaning solvents, oil based paints/varnishes, and refrigerants. The air in beauty shops, dry cleaning stores, photo processing labs, and storage areas for pool supplies often contains these compounds. Therefore, it is recommended to install as a direct vent (use outside air for combustion). In applications utilizing room air where there are high levels of particulates, Rinnai offers a room air screen. The water heater, venting, and vent termination(s) should not be installed in any areas where the air may contain these corrosive compounds.

Clearances

| Location | Clearance |
|---|--|
| Top of tank | <ul style="list-style-type: none"> • 12 in. (305 mm) • 0 in. from vent components • Clearance for servicing the anode rods is 54 in. (1.4 m) from top of water heater |
| Bottom (Ground) | 0 in. |
| Back of tank | 0 in. |
| Front of tankless water heaters | 0 in. Clearance for servicing is 24 in. (610 mm) |
| Sides (Left and Right) of tankless water heaters | 2 in. (51 mm) |

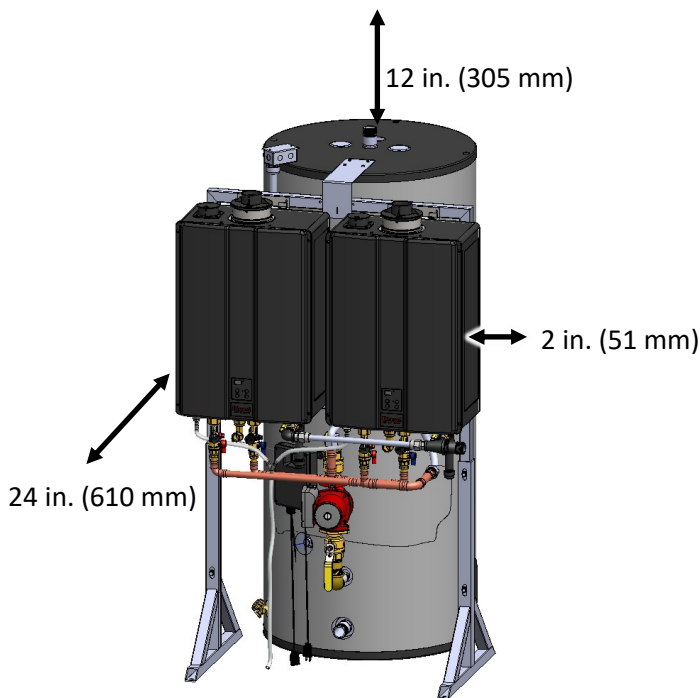

5 Installation Instructions

Step 1: Transport

1. Choose the right hand truck to support the weight and size of the water heater. Refer to the **Specifications** section in this manual for specific weights and dimensions.
2. Use proper lifting techniques to load the tank onto the hand truck:
 - Position the tank onto the hand truck so the weight is evenly balanced and the tank is touching the rails of the hand truck.
 - Secure the water heater to the hand truck:
 - Position **STRAP A** around the top of the tank as illustrated below.
 - Position **STRAP B** around the base of the tank below the pump assembly.

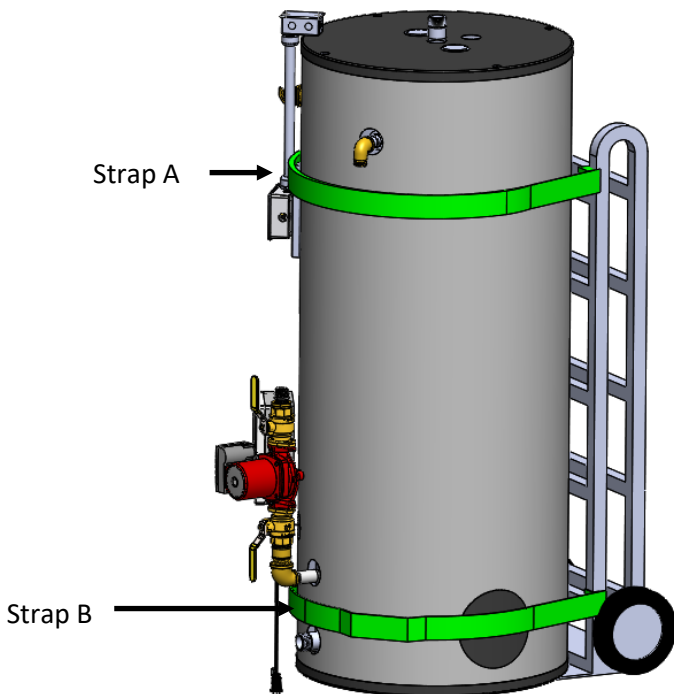

Step 2: Secure for Earthquake

NOTICE

Products installed in the state of California must be braced, anchored, or otherwise secured to avoid motion or falling during an earthquake. Contact the California Office of the State Architect located at 1102 Q Street, Suite 5100, Sacramento, CA 95811 for instructions.

IMPORTANT

Position straps around the tank per the requirements of California Office of the State Architect. **DO NOT POSITION THE STRAPS OVER PUMP, PIPE, FITTINGS OR WIRE.**

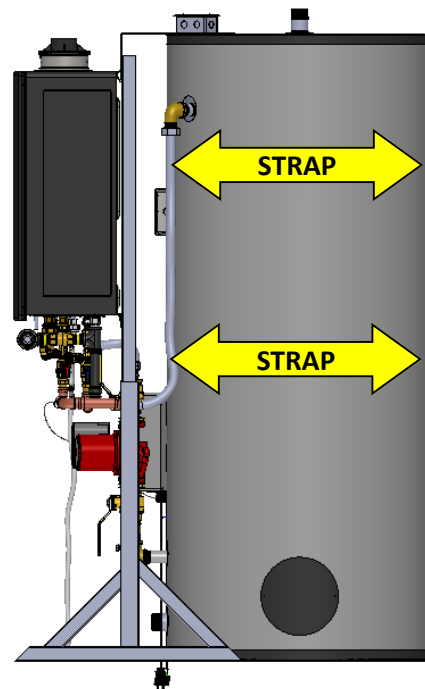

Step 3: Position Tank and Connect Water

When positioning the tank and connecting water, follow these guidelines:

- Water connections to the Demand Duo™ 2 must follow all state and local plumbing codes.
- When assembling the hot and cold water piping, use a high quality food grade pipe joint compound and ensure all fittings are tight.
- DO NOT apply an open flame to the inlet and outlet fittings, as heat will damage or destroy the plastic lined fittings. This will result in premature failure of the fittings, which is not covered by the warranty.
- For standard installations, refer to the **Piping Diagram for Basic Installations** in the **Appendix**.

To position the tank and connect water:

1. Position the tank in the desired location.
2. Connect piping to the cold water inlet connection (1.5 in./38 mm MNPT). See **A** in image below.
 - Keep the pipe as close as possible to one side of the tank; this allows the rack frame to position closer to the tank and allow for easier flex line connection (see **B**).
 - Maximum pipe length from the cold water inlet connection to the rack frame leg is 17.77 in. (451 mm) (see **C**).
3. Connect piping to the hot water outlet connection (1.5 in./38 mm MNPT) (see **D**).
4. Install a shut-off valve on the cold and hot water lines (see **E**).
5. Rinnai recommends to install unions on the cold and hot water lines so that the water heater can easily disconnect if servicing is required (see **F**).

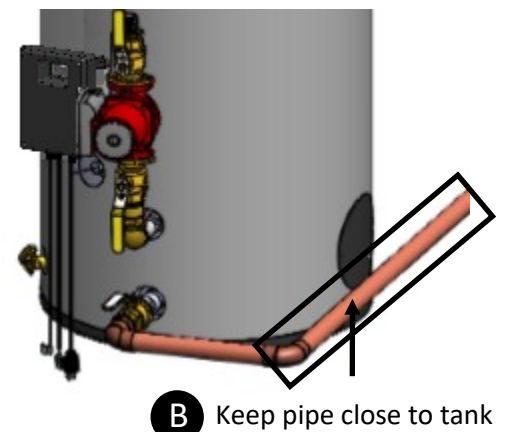
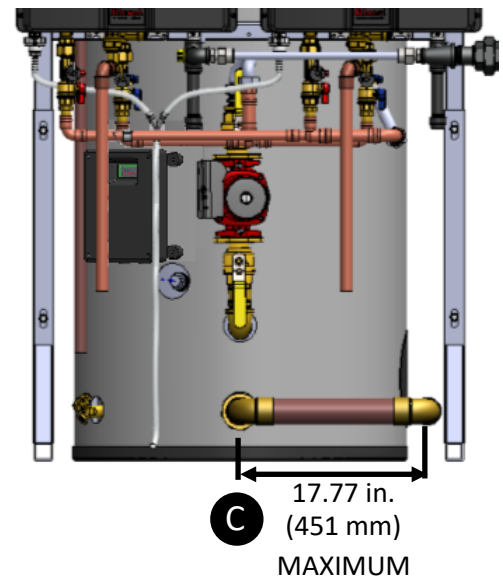
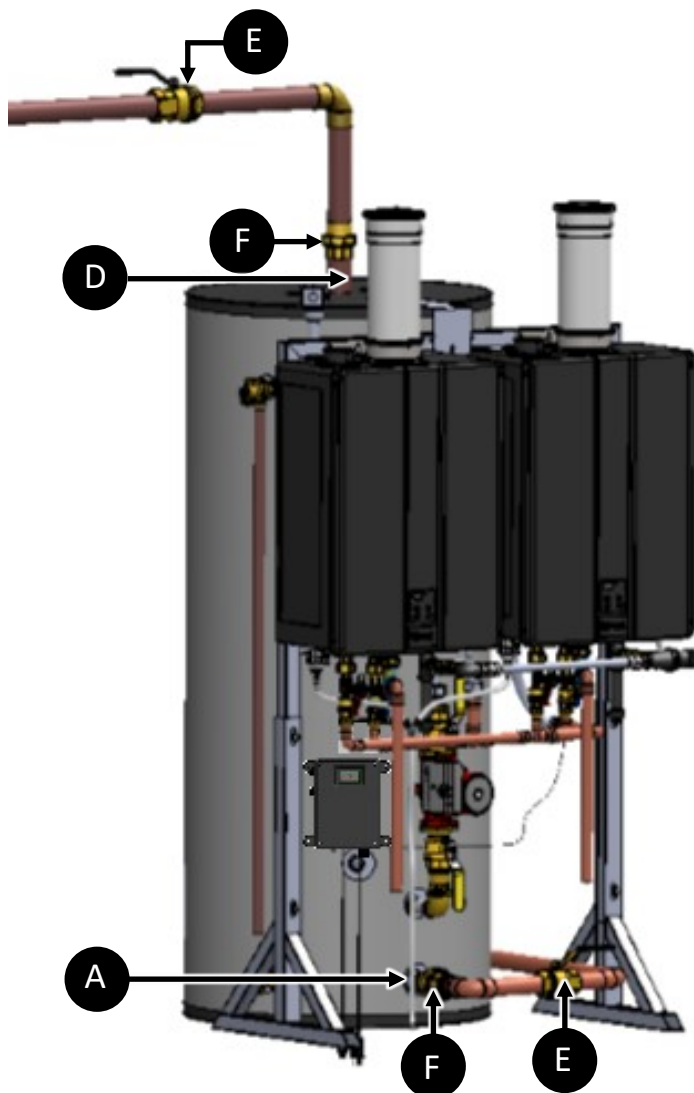

Step 4: Install Rack Frame Legs

To install the rack frame legs:

1. Lay the rack assembly down on the shipping pallet.

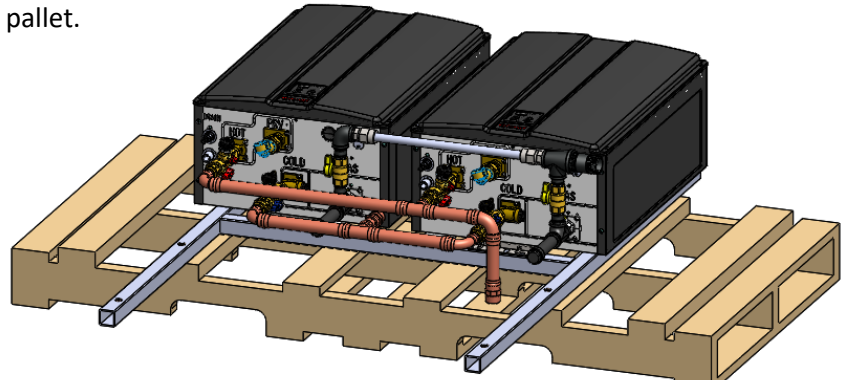

2. Position the frame legs (supplied) on each rack leg so that the threaded inserts are centered over the open slots.

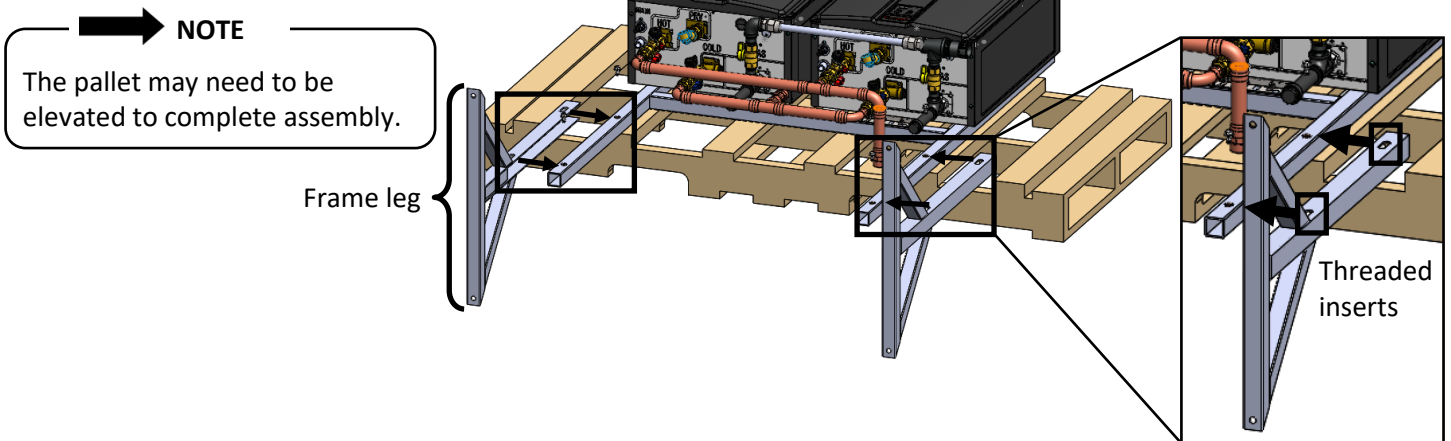

3. Use the supplied 4 bolts (5/16 in. - 18) to fasten the frame legs to the rack legs.

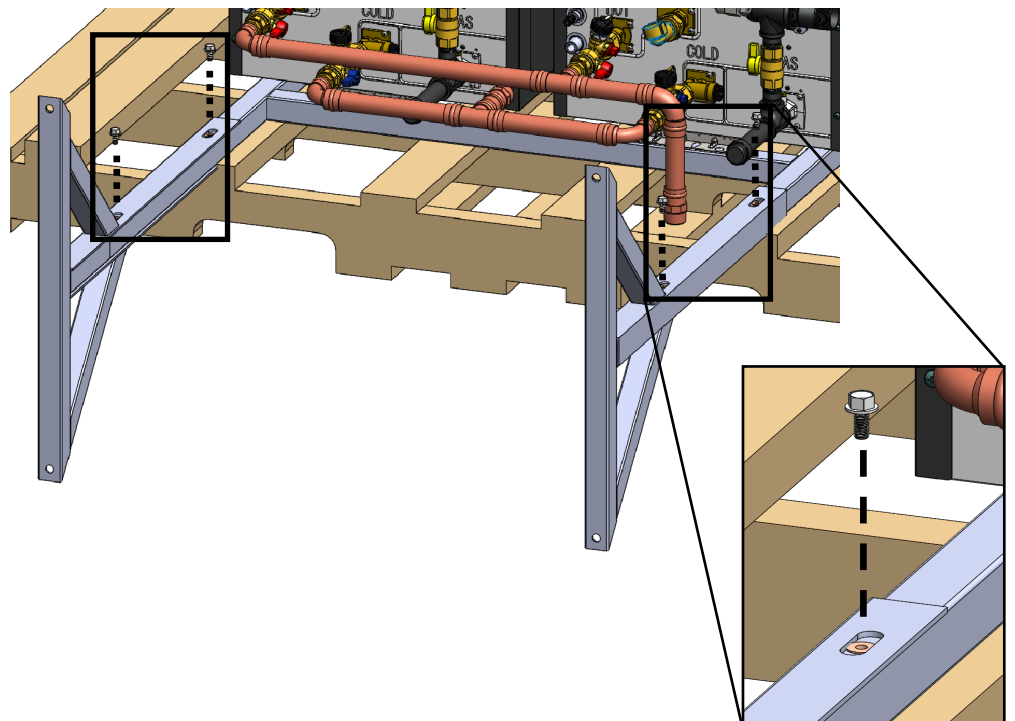

Step 5: Position Rack

To position the rack:

1. Loop hoisting straps (field-supplied) around the rack top frame. Straps should support approximately 220 lb (100 kg).

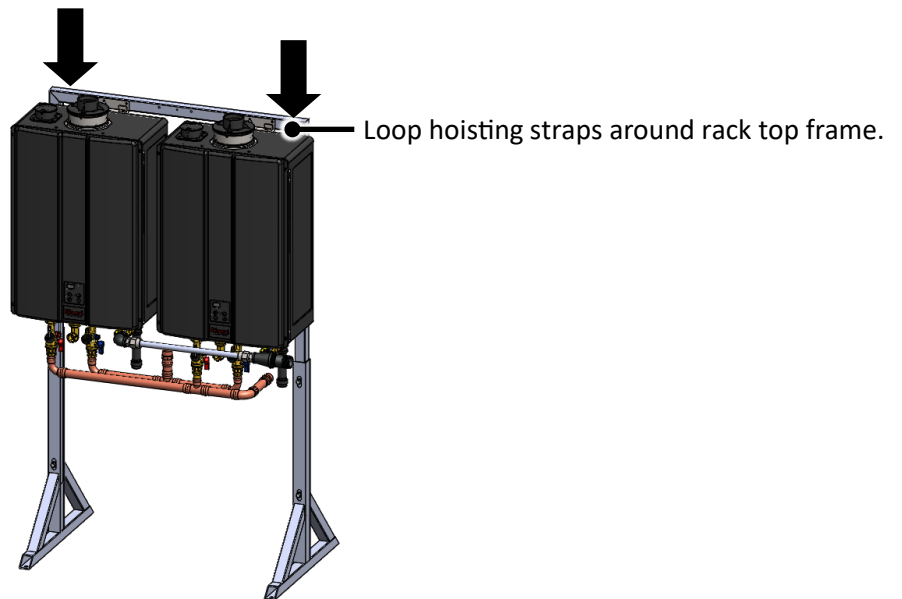

2. Position the rack in front of the tank, and then gently push the rack back as close to the tank as possible so that the flex lines can connect the two assemblies.

Place rack in front of tank

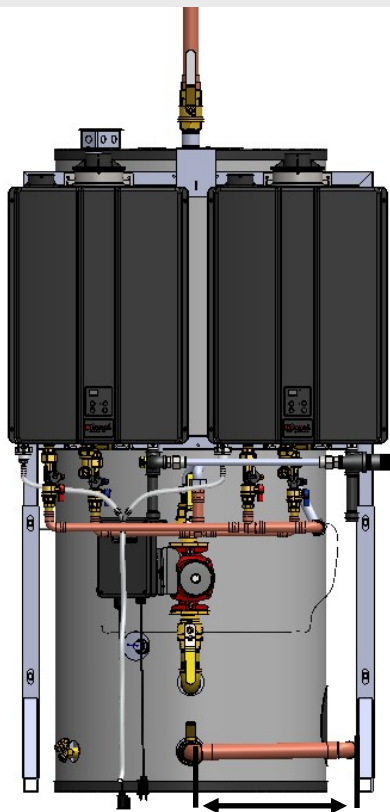

17.77 in. (451 mm)

Push rack back close to tank

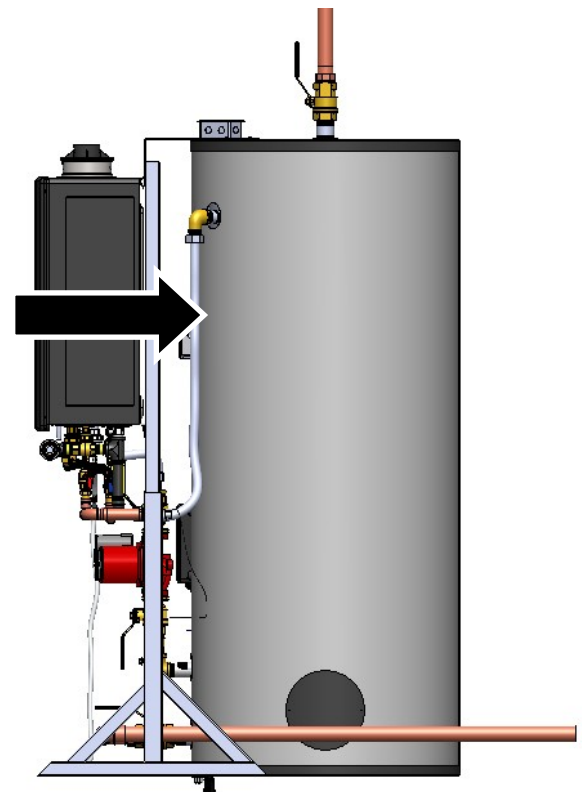

Step 6: Install Water Flex Lines

To install flex lines:

1. Connect the 12 in. (305 mm) flex line from the cold water manifold to the threaded connection on top of the pump. Tighten to 25 ft-lb torque.
Ensure the gasket is in the flex line.

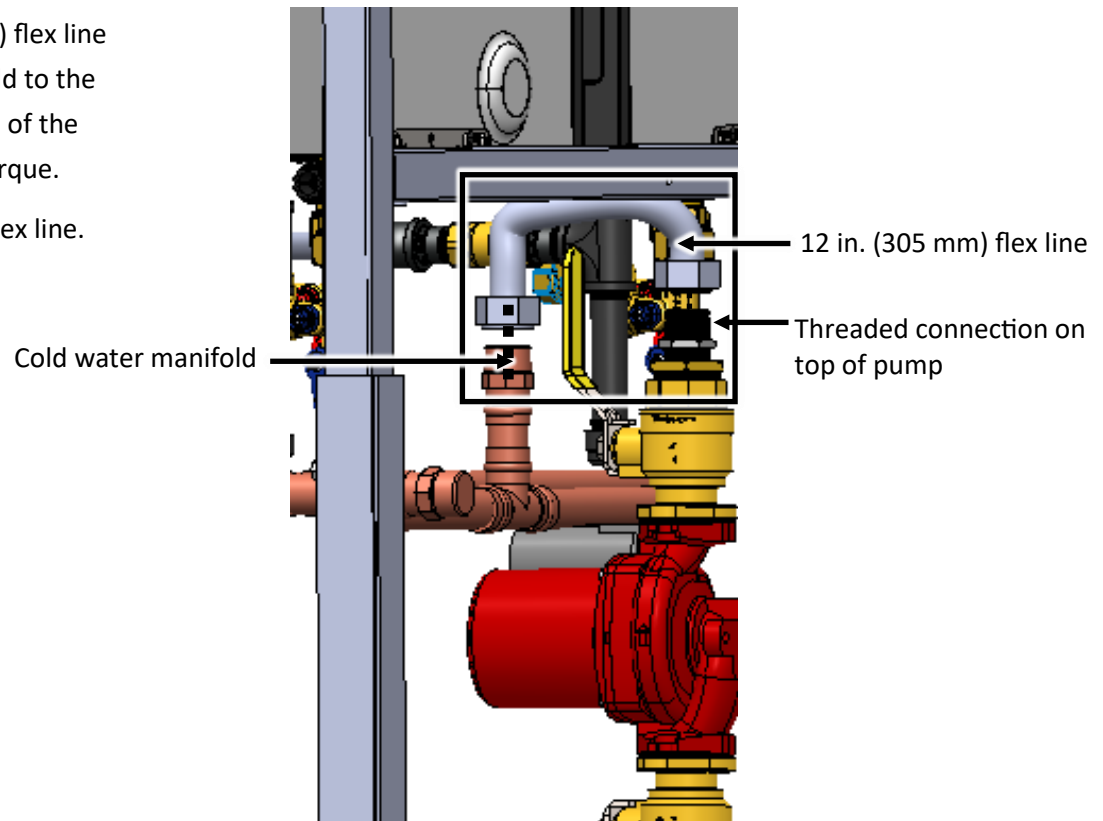

2. Connect the 36 in. (914 mm) flex line from the hot water manifold to the threaded connection at the top of the tank. Tighten to 25 ft-lb torque.

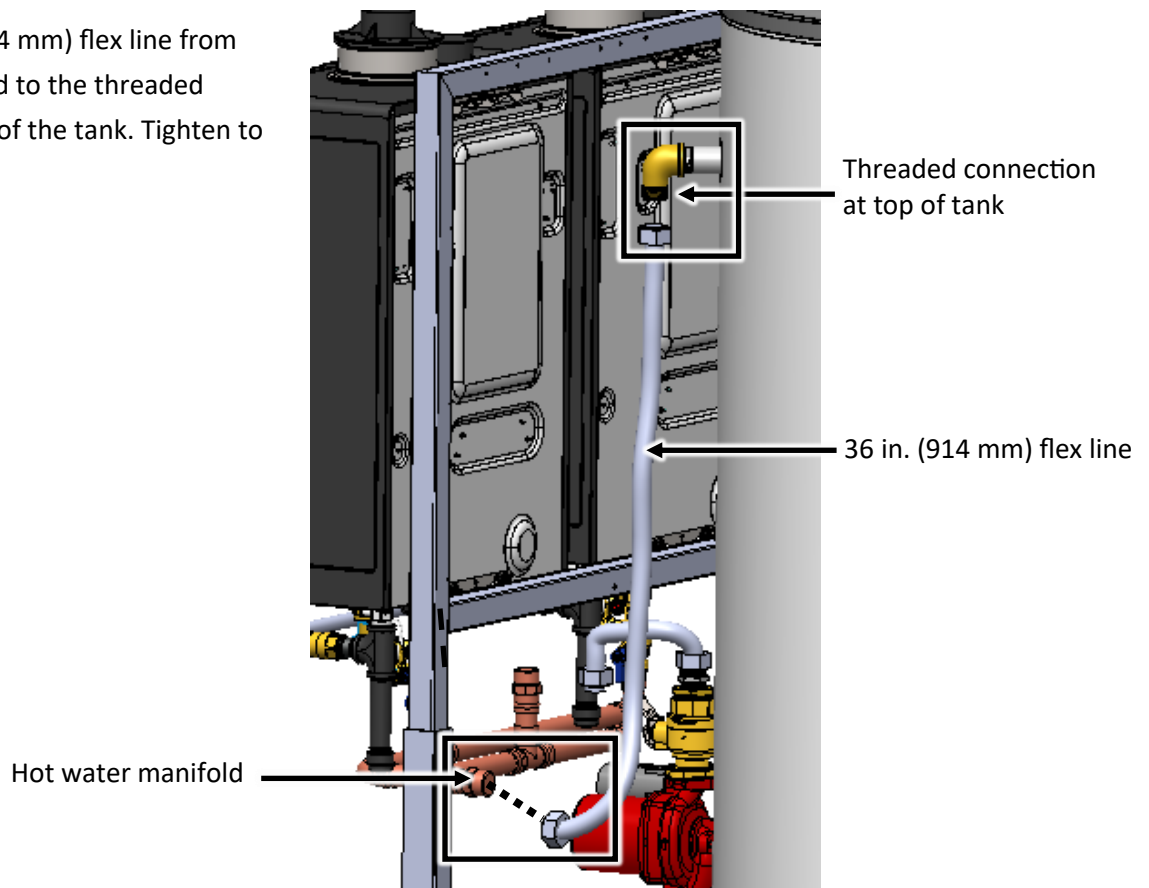

Step 7: Secure Rack

To secure the rack:

1. The rack system must be anchored and secured in accordance with national and/or local codes having jurisdiction.

Base holes to secure the rack are 0.5 in. (13 mm) in diameter. Reference local codes regarding minimum concrete thickness and use appropriate expansion anchors that are capable of supporting the rack system weight of approximately 220 lb (100 kg). Reference and follow the anchor manufacturer's use and installation requirements.

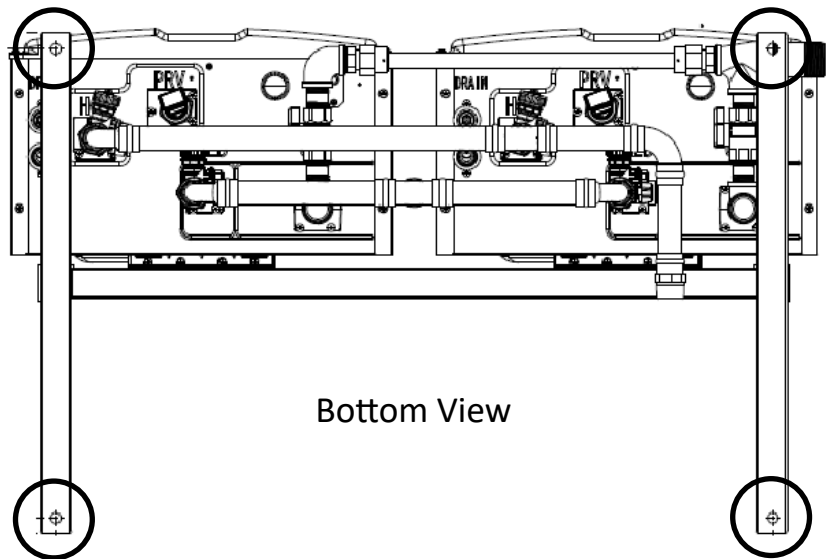

2. Place the securing bracket on top of the tank and over the frame of the rack.

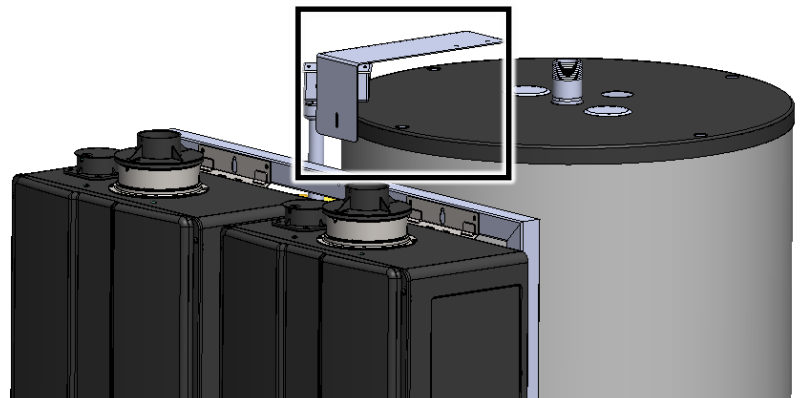

3. Using (4) self-drilling screws, attach the securing bracket to the top of the tank.

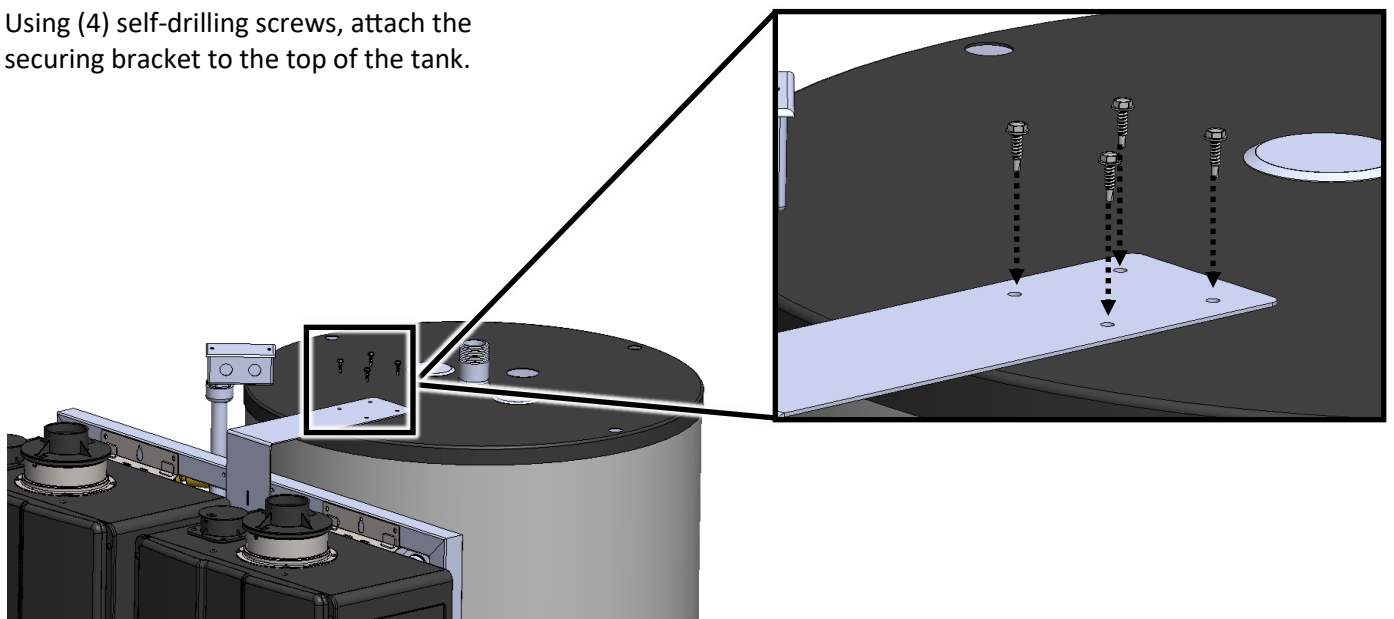

Step 8: Install Vent System

Refer to the Tankless Water Heater Installation and Operation Manual (supplied with each Tankless Water Heater in the Demand Duo™ 2 system) for complete venting information and instructions. Topics in this manual include: Venting Guidelines; Venting Installation Sequence and Instructions; Venting Options; Maximum Vent Lengths; and Termination Considerations.

Step 9: Install Relief Valve Lines

A Pressure Relief Valve (PRV) is pre-installed on each tankless water heater in the Demand Duo™ 2 system. A combination Temperature and Pressure (T&P) Relief Valve is pre-installed on the tank. Install a drain pipe from each PRV and T&P Valve into a floor drain as shown in the diagram below. Refer to the guidelines on the next page.

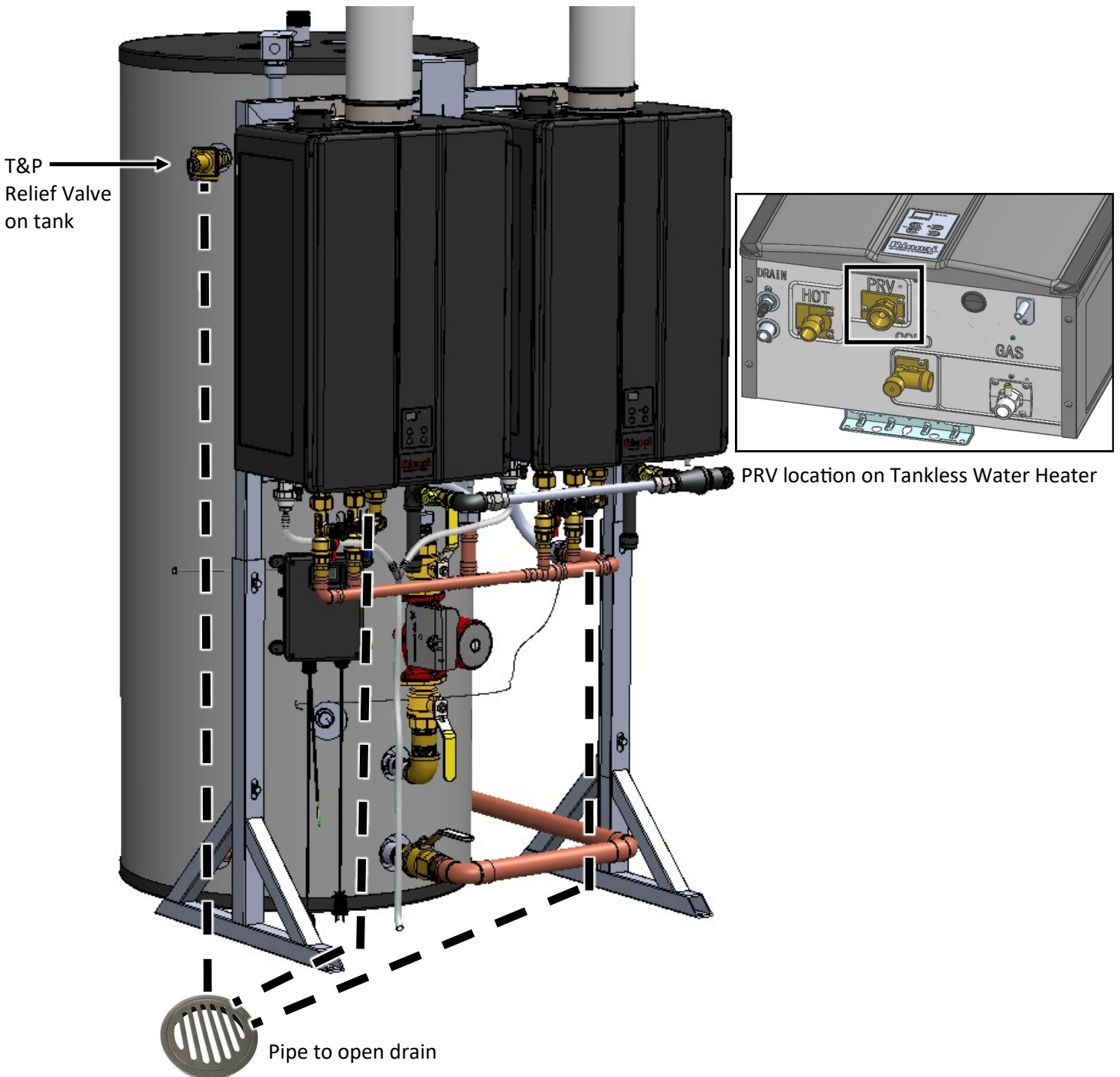

PRV Requirements

- An approved PRV (pre-installed on each tankless water heater in the Demand Duo™ 2 system) is required by the *American National Standard (ANSI Z21.10.3)* for all water heating systems and shall be accessible for servicing.
- The PRV must comply with the standard for *Relief Valves and Automatic Gas Shutoff Devices for Hot Water Supply Systems ANSI Z21.22* and /or the standard *Temperature, Pressure, Temperature and Pressure Relief Valves and Vacuum Relief Valves, CAN1-4.4*.
- The PRV must be rated up to 150 psi and to at least the maximum BTU/hr of the appliance.
- The discharge from the PRV should be piped to the ground or into a drain system per local codes.
- The PRV must be manually operated once a year to check for correct operation.
- The PRV should be added to the hot water outlet line and near the hot water outlet according to the manufacturer's instructions. DO NOT place any other type valve or shut-off device between the PRV and the water heater.
- If a PRV discharges periodically, this may be due to thermal expansion in a closed water supply system. Contact the water supplier or local plumbing inspector on how to correct this situation. Do not plug the PRV.

WARNING

- Water discharged from the PRV could cause severe burns instantly or death from scalds.
- DO NOT plug the PRV and do not install any reducing fittings or other restrictions in the relief line. The relief line should allow for complete drainage of the valve and the line.
- DO NOT place any other type valve or shut-off device between the PRV and the water heater.
- DO NOT pipe the T&P Relief Valve, PRV, and/or condensate drain together into a common pipe.

T&P Relief Valve Requirements

- For safe operation, the relief valve(s) must not be removed from its designated point of installation or plugged.
- An approved T&P Relief Valve is required by the *American National Standard (ANSI Z21.10.3)* for all water heating systems and shall be accessible for servicing.
- The T&P Relief Valve must comply with the standard for *Relief Valves and Automatic Gas Shutoff Devices for Hot Water Supply Systems ANSI Z21.22* and /or the standard *Temperature, Pressure, Temperature and Pressure Relief Valves and Vacuum Relief Valves, CAN1-4.4*.
- The T&P Relief Valve must be rated up to 150 psi and to at least the maximum BTU/hr of the appliance.
- The discharge from the T&P Relief Valve should be piped to the ground or into a drain system to prevent exposure or possible burn hazards to humans or other plant or animal life. Follow local codes. Water discharged from the relief valve could cause severe burns instantly, scalds, or death.
- The T&P Relief Valve must be manually operated once a year to check for correct operation.

WARNING

- DO NOT plug the T&P Relief Valve and do not install any reducing fittings or other restrictions in the relief line. The relief line should allow for complete drainage of the T&P Relief Valve and the line.
- DO NOT place any other type valve or shut off device between the T&P Relief Valve and the water heater.
- DO NOT pipe the T&P Relief Valve, PRV, and/or condensate drain together into a common pipe.

Step 10: Fill System with Water

When filling the system with water, follow these guidelines:

- To prevent damage to the water heater, all air must be relieved from the system and a hot water fixture must be flowing water before the water heater is plugged in and turned on.

NOTICE

DO NOT OPERATE THE WATER HEATER UNLESS IT IS COMPLETELY FULL OF WATER.

To fill the system with water:

1. Ensure the drain valve located at the bottom of the tank is closed (see **A** below).
2. Open the nearest hot water fixture.
3. Open the cold water supply valve to the water heater (see **B**).
4. Keep the hot water fixture open until the tank is filled and constant flow is obtained at the fixture.
5. Close the hot water fixture.
6. Check water heater connections and plumbing system for damage or leaks. Repair if needed.
7. Connect a hose (such as a standard garden hose) to the cold drain valve on one of the tankless water heaters and open the valve to allow water out; this ensures no air is trapped inside the pump (see **C**).

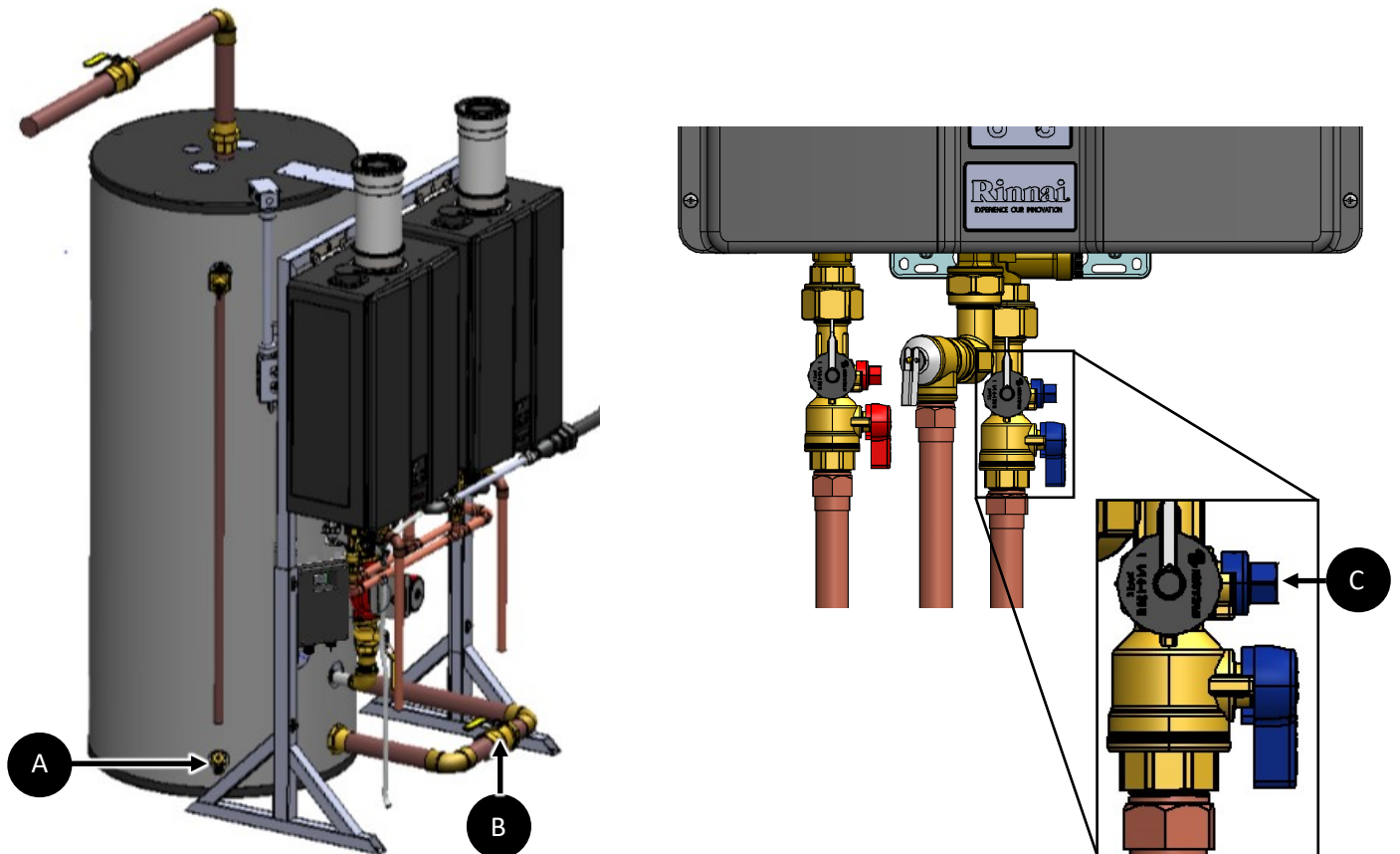

Step 11: Connect Condensate Drain Line

Condensate can form in the vent of high efficiency, direct vent tankless water heaters. Without proper drainage, condensate will damage the heat exchanger located inside the tankless water heater.

When connecting the condensate drain line, follow these guidelines:

- Use only corrosion-resistant materials for the condensate drain lines, such as PVC pipe or plastic hose.
- The condensate drain line should be as short as possible and have a downward pitch.
- The end of the condensate drain line should be open to the atmosphere. The end should not be under water or other substances.



CORRECT

Drain line open to atmosphere

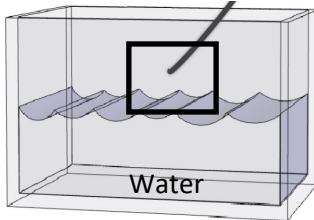

NOT CORRECT

Drain line submerged in water

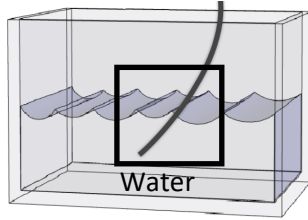

- Ensure that the condensate drain, PRV, and T&P Relief Valve are piped separately to their own dedicated drain lines.
- If the condensate drain gets blocked, a diagnostic code will display on the controller. If this occurs, the condensate drain must be cleaned.
- The condensate trap will automatically prime (self-prime) during operation of the unit as condensate forms. Condensate draining from the unit indicates that the trap is full and that there is no blockage in the condensate drain. It is not necessary to add water to the condensate trap.
- A condensate neutralizer kit is available from Rinnai. The kit allows condensate to flow through neutralizing media that raises the pH of the condensate to a level that will help prevent corrosion of the drain and public sewer system.
- All condensate must drain and be disposed of according to local codes.

WARNING

- DO NOT connect the condensate drain line directly to the rain sewer.
- DO NOT connect the condensate drain line with an air conditioning evaporator coil drain.
- DO NOT pipe condensate drain, temperature-pressure relief valve, and/or pressure relief valve together into a common pipe.
- Water heaters have an integrated condensate trap. DO NOT install an external condensate trap.



EXTERNAL TRAP NOT REQUIRED

To connect the condensate line:

Place the condensate drain line (1/2 in. clear vinyl tubing) towards the drain.

Keep the drain line open to the atmosphere and NOT under water or other substances.

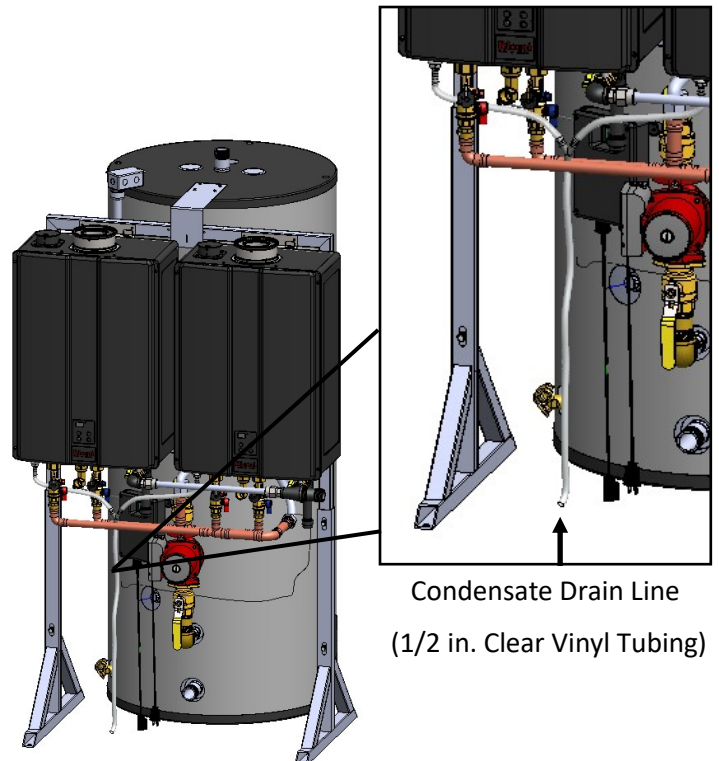

Step 12: Connect Gas Supply

WARNING

- A licensed professional must install the gas supply.
- Turn off 120V power supply.
- Turn off the gas.
- Gas is flammable. Do not smoke or provide other ignition sources while working with gas.
- Do not turn on the water heater or gas until all fumes are gone.

To connect the gas supply:

1. Install a manual gas control valve in the gas supply line to the water heater. A union can be used on the connection above the shut off valve for the future servicing or disconnection of the water heater (see image to right).
2. Check the type of gas and gas supply pressure before connecting the water heater. If the water heater is not of the gas type that the building is supplied with, **DO NOT** connect the water heater. Contact the dealer for the proper water heater to match the gas type.
3. Check the gas supply pressure immediately upstream at a location provided by the gas company. Supplied gas pressure must be within the limits shown in the **Specifications** section of this manual with all gas appliances operating.
4. Before placing the appliance in operation, all joints, including the water heater, must be checked for gas tightness by means of soap, gas leak detector solution, or an equivalent nonflammable solution, as applicable. Since some leak test solutions, including soap and water, may cause corrosion or stress cracking, rinse the piping with water after testing, unless it has been determined that the leak test solution is non-corrosive.
5. Use approved connectors to connect the water heater to the gas line. Purge the gas line of any debris before connection to the water heater.
6. Any compound used on the threaded joint of the gas piping must be chemically compatible and mechanically suitable to be used in liquefied petroleum gas (LPG/Propane) applications.

7. The gas supply line shall be gas tight, sized, and installed to provide a supply of gas sufficient to meet the maximum demand of the water heater and all other gas-consuming appliances at the location without loss of pressure. If in doubt about the size of the gas line, refer to the Installation and Operation Manual for Commercial CU199 Condensing Tankless Water Heaters.
8. Perform a leak and pressure test prior to operating the water heater. If a leak is detected, do not operate the water heater until the leak is repaired.

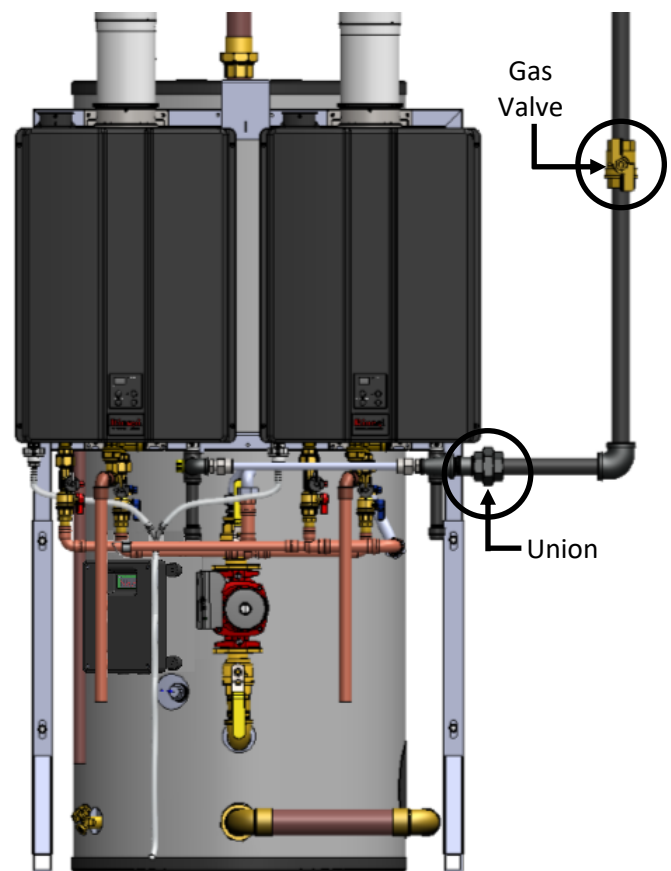

Gas Valve and Union Connections

Step 13: Connect Communication Cable

To connect the communication cable:

1. Route the communication cable from the digital controller through the bottom side of the tankless water heater.
2. Plug the communication cable into the serial port located at the front top side of the tankless PC Board.

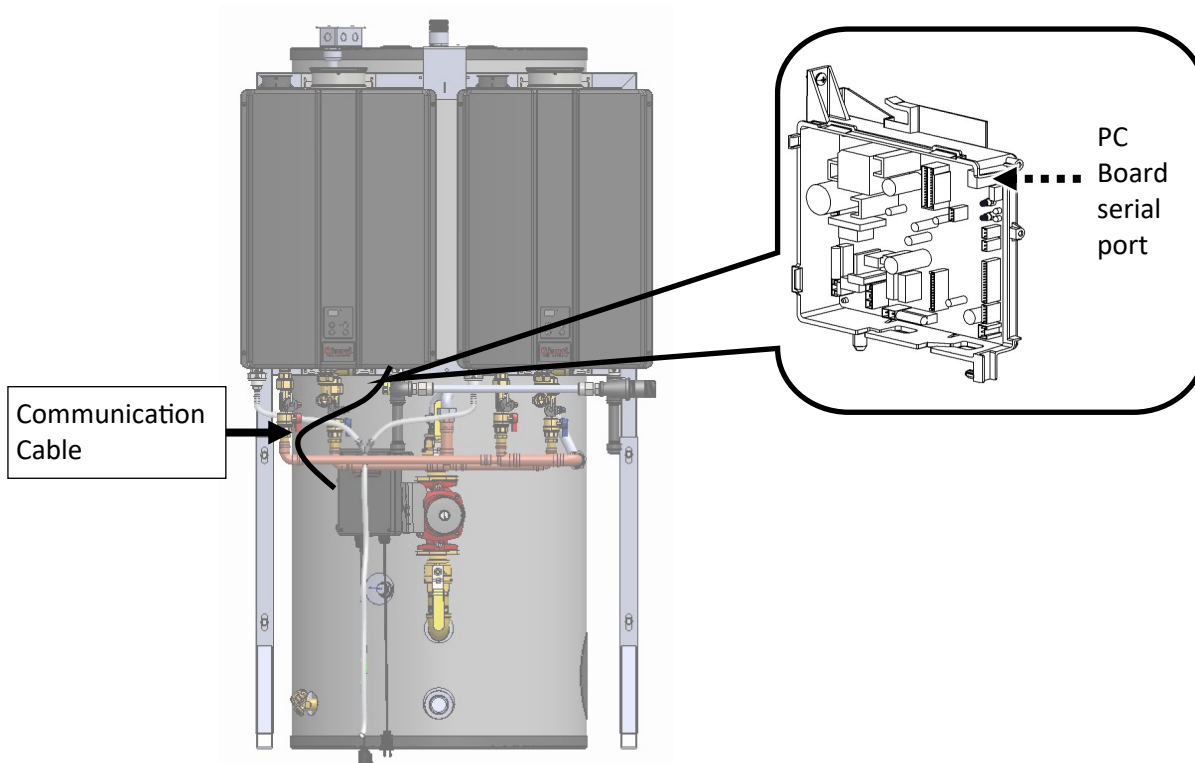

Step 14: Connect Power Supply

When connecting the power supply, follow these guidelines:

- Do not rely on the gas or water piping to ground the water heater. Ground locations are provided inside the water heater.
- The water heater requires 120 VAC, 60 Hz power from a properly grounded circuit.
- Do not connect power to the Demand Duo™ 2 system prior to completing installation and the system has been filled with water.
- The Tankless Water Heater wiring diagram is located on the inside of the water heater front cover. The controller wiring diagram is located on the inside front cover of the controller.
- When power is supplied, the digital controller maintains pump operation. If the Demand Duo™ 2 system is not in use for an extended period of time, disconnect power from the system.

⚠ WARNING ⚡

- Do not use an extension cord or adapter plug with this appliance.
- The water heater must be electrically grounded in accordance with local codes and ordinances or, in the absence of local codes, in accordance with the National Electrical Code, ANSI/NFPA No. 70.
- Indoor water heaters are equipped with a three-prong (grounding) plug for your protection against shock hazard and should be plugged directly into a properly grounded three-prong receptacle. Do not cut or remove the grounding terminal from this plug.

To connect the power supply:

1. A 4-unit electrical assembly is pre-installed on the storage tank for single point electrical connection (Refer to the **Specifications** sections in this manual for electrical requirements).

Connect power to the electrical assembly by following the steps below.

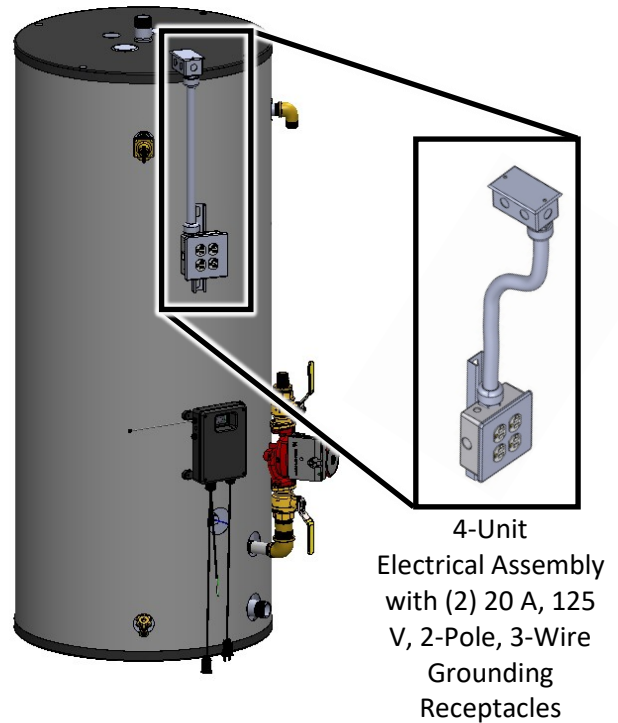

⚠ WARNING ⚡

Shut off building supply power prior to connecting to the electrical assembly. Failure to do so may result in property damage, bodily harm, or death.

- a. Locate the gang box on top of the storage tank.

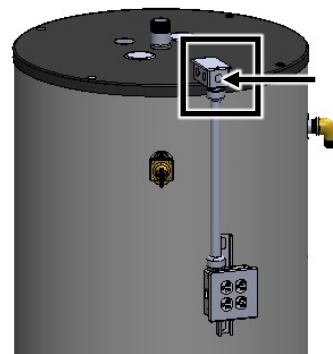

- b. Remove the 2 screws securing the front panel to the gang box. Then, remove the front panel.

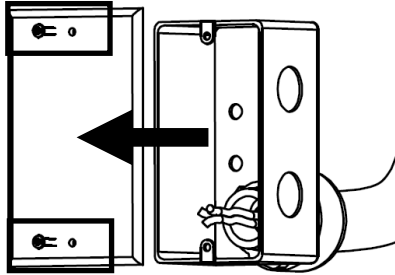

- c. Run building-supplied electrical wiring and conduit to the gang box.

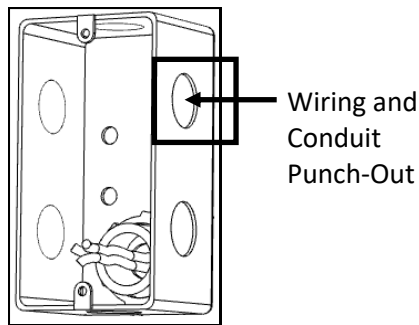

- d. Connect the building wiring to the (3) 12 AWG, THHN wires: Hot (Black), Neutral (White), and Ground (Green). Use wire nuts or other approved wire connectors.

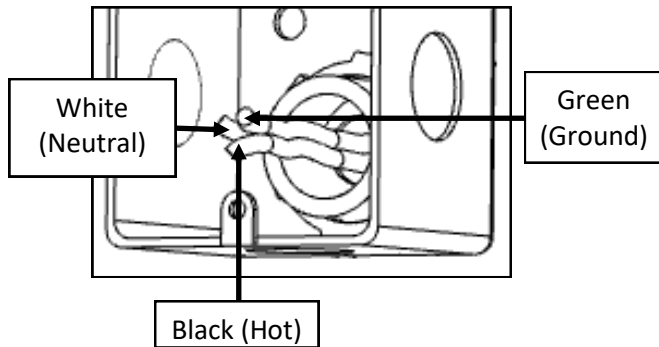

- e. Use the 2 screws to reinstall the front panel to the gang box.
- f. When the building electrical power supply has been wired to the rack system, plug the two tankless units into the electrical assembly.

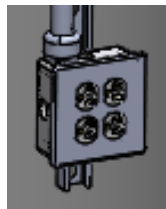

2. Plug the controller power cord into the electrical assembly on the storage tank.

WARNING

DO NOT plug the controller power cord into the electrical assembly until the storage tank is filled as the pump will overheat.

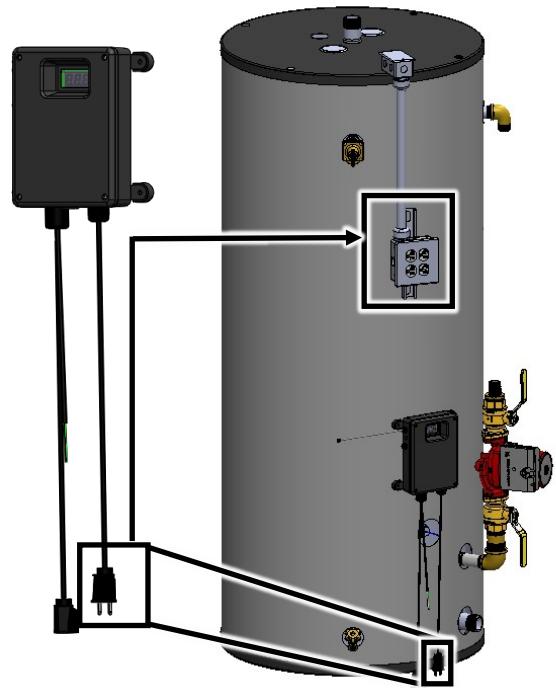

- The digital controller maintains communication between the tank and tankless water heater to effectively control the tank temperature based on the selected temperature on the tankless water heater.
- By reading the tank temperature and tankless outlet temperature, the digital controller turns on the pump when the tank temperature drops. When the tank temperature returns to the selected set temperature, the digital controller turns off the pump and remains in standby until the tank temperature drops again.
- Refer to the **Controller Diagnostics** section in the **Appendix** for controller diagnostic information.

Post-Installation Checklist

Complete the following checklist when installation is complete. You should be able to answer YES to each question. If you answer NO, installation is not complete. Refer to the applicable section in this manual and the tankless water heater installation and manual for additional information.

| INSTALLATION DETAILS | YES | NO |
|--|--------------------------|--------------------------|
| Have you verified the unit, vent and air intakes meet the clearance requirements? | <input type="checkbox"/> | <input type="checkbox"/> |
| Are parameter settings configured appropriately for the altitude? | <input type="checkbox"/> | <input type="checkbox"/> |
| Are the tankless water heater front panels installed? | <input type="checkbox"/> | <input type="checkbox"/> |
| Does the installation conform with local codes or, in the absence of local codes, with the <i>National Fuel Gas Code, ANSI Z223.1/NFPA 54</i> , or the <i>Natural Gas and Propane Installation Code, CSA B149.1</i> ? | <input type="checkbox"/> | <input type="checkbox"/> |
| VENTING | YES | NO |
| Are the correct venting products for the installed system being utilized? | <input type="checkbox"/> | <input type="checkbox"/> |
| Have you followed the venting manufacturer's installation instructions and the installation instructions in this document? | <input type="checkbox"/> | <input type="checkbox"/> |
| Have you verified the water heater is not subject to corrosive compounds in the air? | <input type="checkbox"/> | <input type="checkbox"/> |
| Have you verified the vent system does not exceed the maximum length for the number of elbows used? | <input type="checkbox"/> | <input type="checkbox"/> |
| Did you explain to the customer the importance of not blocking the vent termination or air intake? | <input type="checkbox"/> | <input type="checkbox"/> |
| SYSTEM PIPING | YES | NO |
| Have you verified the water supply does not contain chemicals or exceed total hardness that will damage the heat exchanger? | <input type="checkbox"/> | <input type="checkbox"/> |
| Did you ensure the hot and cold water lines are not crossed to the unit and are leak free? | <input type="checkbox"/> | <input type="checkbox"/> |
| Did you place a manual gas control valve in the gas line to the water heater? | <input type="checkbox"/> | <input type="checkbox"/> |
| Did you ensure that a pressure relief valve is installed with a rating at least the maximum BTU/hr of the appliance? Refer to the rating plate on the side of the tankless water heater for BTU input. | <input type="checkbox"/> | <input type="checkbox"/> |
| Did you clean the inlet water filter by closing the cold and hot water inlet isolation (shut-off) valves? (Put a bucket under the filter at the bottom of the water heater to catch any water that is contained inside the unit. Unscrew the water filter. Rinse the filter to remove any debris. Install the filter and open the isolation valves.) | <input type="checkbox"/> | <input type="checkbox"/> |
| Have you verified that no toxic chemicals were introduced to the potable water? | <input type="checkbox"/> | <input type="checkbox"/> |
| Did you drain the water from the heat exchanger if the water heater is not needed for immediate use? | <input type="checkbox"/> | <input type="checkbox"/> |
| GAS SUPPLY | YES | NO |
| Have you performed a gas line and connection leak test? | <input type="checkbox"/> | <input type="checkbox"/> |
| Is the inlet gas pressure within limits? | <input type="checkbox"/> | <input type="checkbox"/> |
| Did you verify the water heater is rated for the gas type supplied? | <input type="checkbox"/> | <input type="checkbox"/> |
| Have you verified the system is functioning correctly by connecting your manometer to the gas pressure test port on the water heater? Operate all gas appliances in the home or facility at high fire. The inlet gas pressure at the water heater must not drop below that listed on the rating plate. | <input type="checkbox"/> | <input type="checkbox"/> |
| POWER SUPPLY | YES | NO |
| Have you confirmed that the electricity is supplied from a 120 VAC, 60 Hz power source; is in a properly grounded circuit; and turned on? | <input type="checkbox"/> | <input type="checkbox"/> |
| Have you verified the temperature controller is functioning properly? | <input type="checkbox"/> | <input type="checkbox"/> |
| OTHER | YES | NO |
| Have you explained to the customer the operation of the water heater, safety guidelines, maintenance, and warranty? | <input type="checkbox"/> | <input type="checkbox"/> |
| Did you leave this manual and the Water Heater Installation and Operation Manual(s) taped to the water heater? Or you may give both manuals directly to the consumer. | <input type="checkbox"/> | <input type="checkbox"/> |

6 Maintenance

Storage Tank Anodes

The storage tank is equipped with two magnesium anodes designed to extend the life of the storage tank. Slowly consumed over time, the anode protects the glass-lined tank from corrosion. Rinnai strongly recommends to inspect the anodes every two (2) years. If more than half of the anodes have been consumed, they should be replaced. Instructions on how to change the anodes can be obtained from the manufacturer.

The longevity of the storage tank can be reduced when a water softener is introduced to fight hard water. Sodium salts added by a softener can make the water extremely conductive; therefore, the anodes are consumed at a faster rate. In such conditions, the anodes should be inspected on a yearly basis.

In certain conditions, the anodes may react with the water, producing discolored or smelly water. The most common complaint is hot water that smells like rotten eggs. This is the result of the reaction between the anode and hydrogen sulphide gas dissolved in the water, which is common in well systems. This issue can usually be eliminated or reduced by changing the magnesium anodes to aluminum anodes and by chlorinating the storage tank and plumbing system. If the problem continues, special filtration equipment may be required. Under no circumstances are the anodes to be removed from the water heater on a permanent basis.

Removal of the anodes will lead to premature failure of the water heater and will void the warranty.

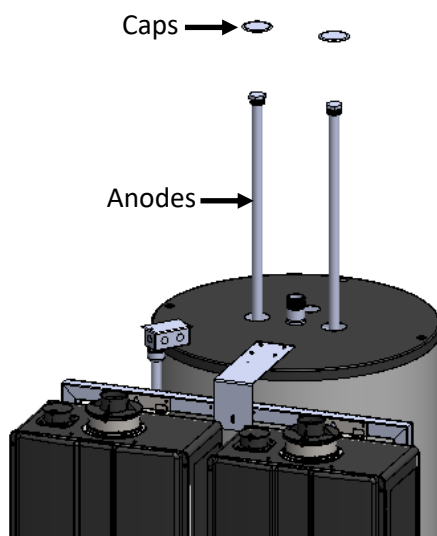

Storage Tank

Drain a pail of water through the drain valve at least once a year. This will remove excess sediment from the bottom of the tank. This sediment, if allowed to accumulate, will reduce the efficiency and the life of the tank.

To drain the storage tank:

1. Turn off power to the system by unplugging power to tankless water heaters and digital controller. (The system will not be fully shut down by pressing the **Power** button on the controller.)
2. Close the cold water supply manual shut-off valve.
3. Connect one end of a garden hose to the storage tank drain valve and put the other end next to a free-flowing drain.
4. Open the drain valve by turning the knob counter-clockwise. ↺
5. Open a hot water faucet to allow air into the system.

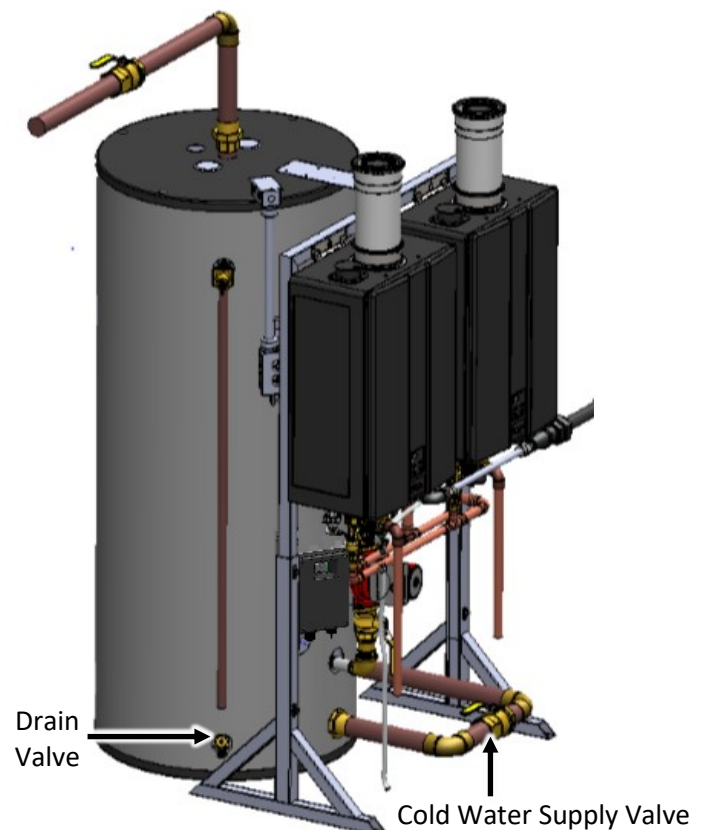

7 Appendices

Piping Diagram for Basic Installations

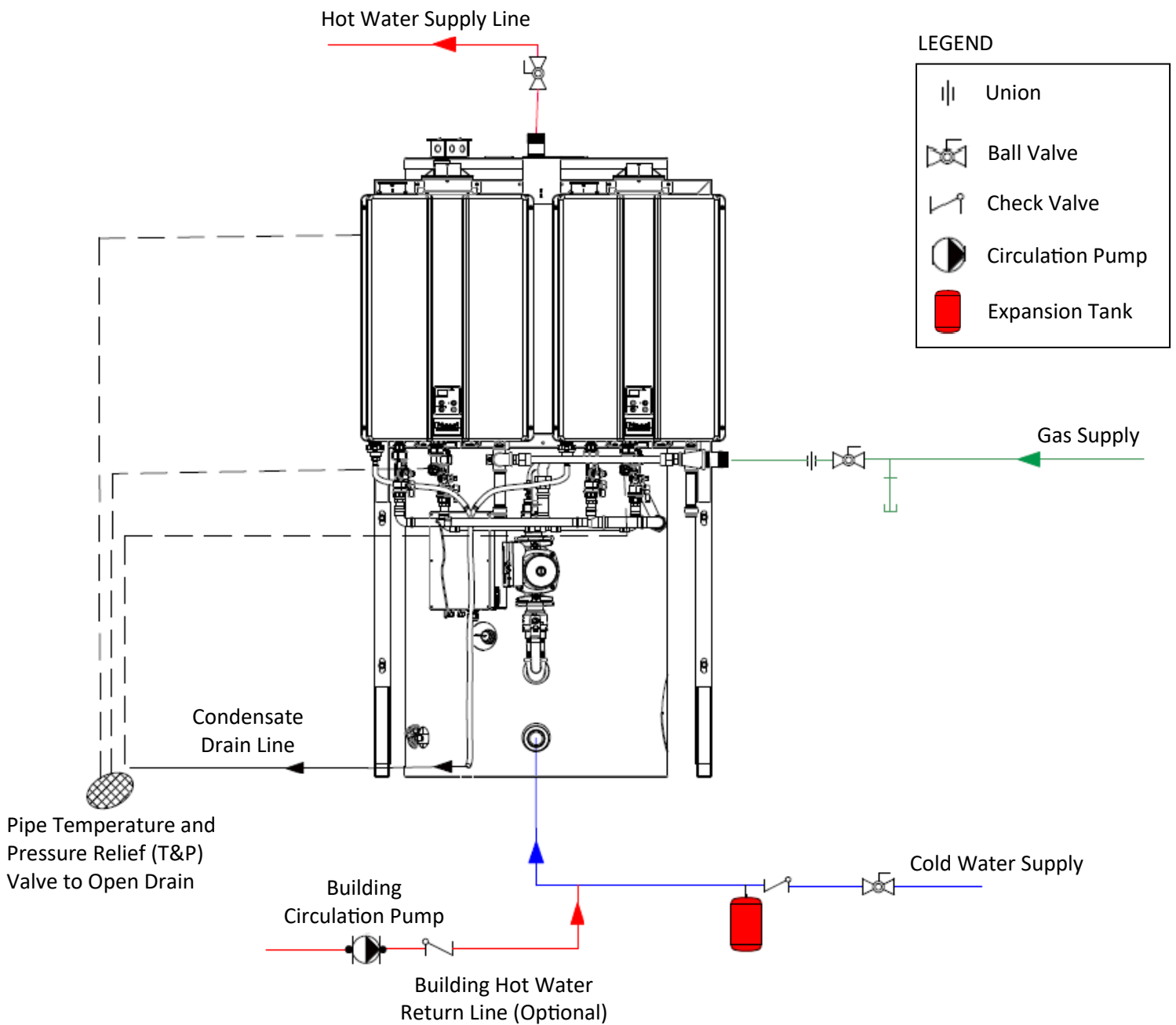

When connecting multiple units, balancing valves, equivalent piping, pressure gauges, and temperature gauges are to be used as necessary to ensure proper flow between units.

Controller Diagnostics

⚠ WARNING

- Do not use an extension cord or adapter plug with this appliance.
- The water heater must be electrically grounded in accordance with local codes and ordinances or, in the absence of local codes, in accordance with the National Electrical Code, ANSI/NFPA No. 70.
- The water heater is equipped with a three-prong (grounding) plug for your protection against shock hazard and should be plugged directly into a properly grounded three-prong receptacle. Do not cut or remove the grounding terminal from this plug.

Guidelines

When connecting the power supply, follow these guidelines:

- Do not rely on the gas or water piping to ground the water heater. Ground locations are provided inside the water heater.
- The water heater requires 120 VAC, 60 Hz power from a properly grounded circuit.
- When using the 5 ft (1.5 m) power cord (included with controller), plug it into a standard 3 prong 120 VAC, 60 Hz properly grounded outlet.
- Do not connect power to the commercial hybrid system prior to completing installation and the system has been filled with water.
- The Tankless Water Heater wiring diagram is located on the inside of the water heater front cover. The controller wiring diagram is located on the inside front cover of the controller.

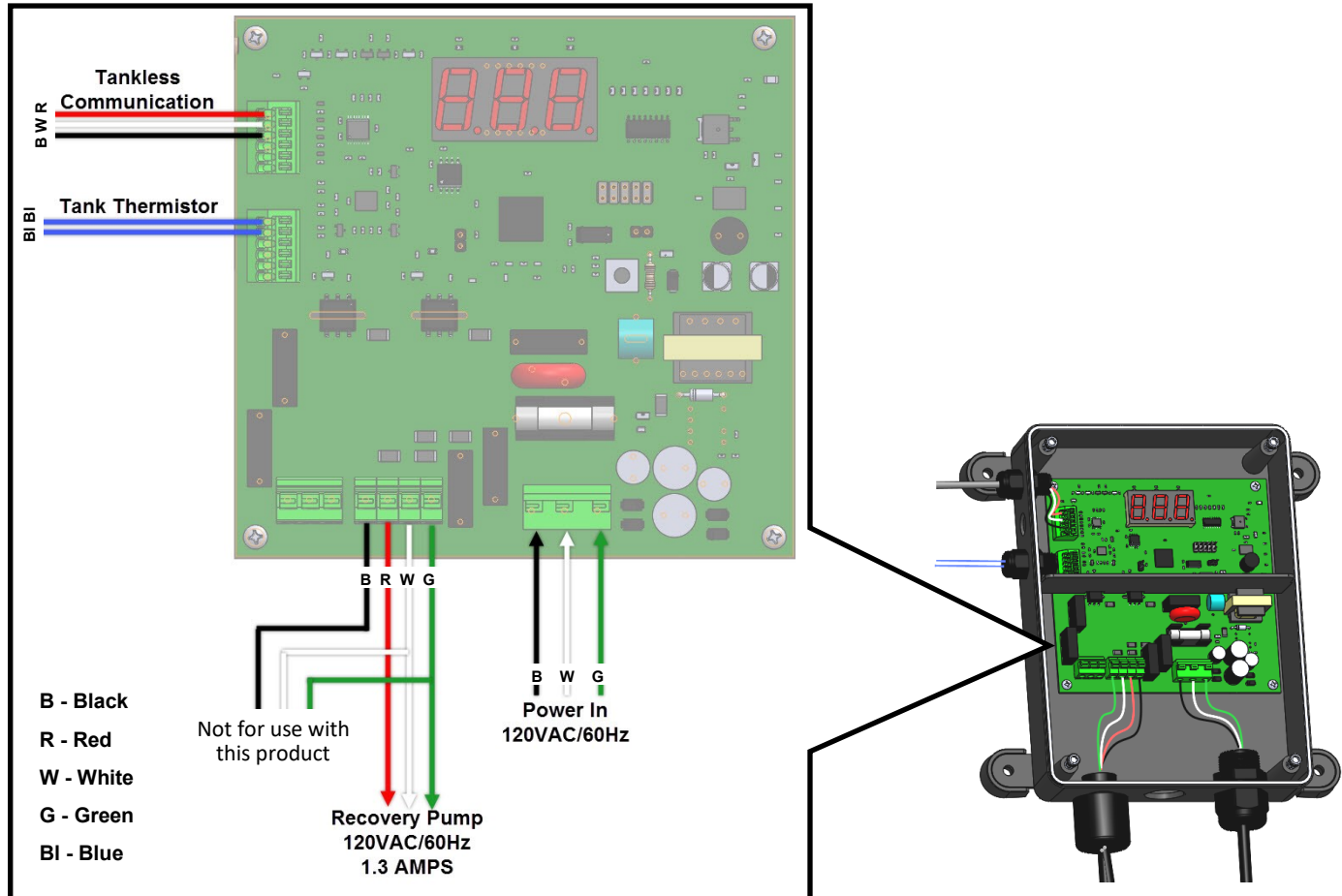

DuoSmart™ Digital Controller

The digital controller maintains communication between the tank and tankless via the tankless communication cable to effectively control the tank temperature based on the selected temperature on the tankless unit.

The digital controller will energize (120V) the pump when the tank temperature drops. When the tank temperature returns to the selected set temperature, the digital controller will de-energize the pump and remain in standby until the tank temperature drops again.



ATTENTION

When power is supplied, the digital controller will maintain pump operation. If system is not in use for an extended period of time, disconnect power from the system.

Controller Diagnostics

Tankless Flow Rate has
dropped below 2.5 GPM

Slow flash indicates
controller is active with
no errors

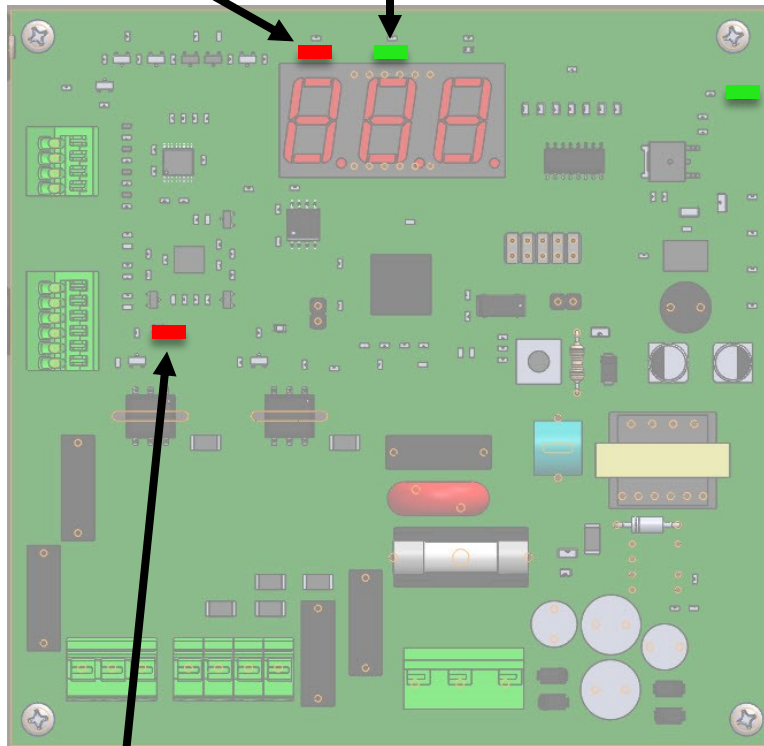

Power supply is
working correctly

Tank Recovery Pump
Activated

Replacement Parts

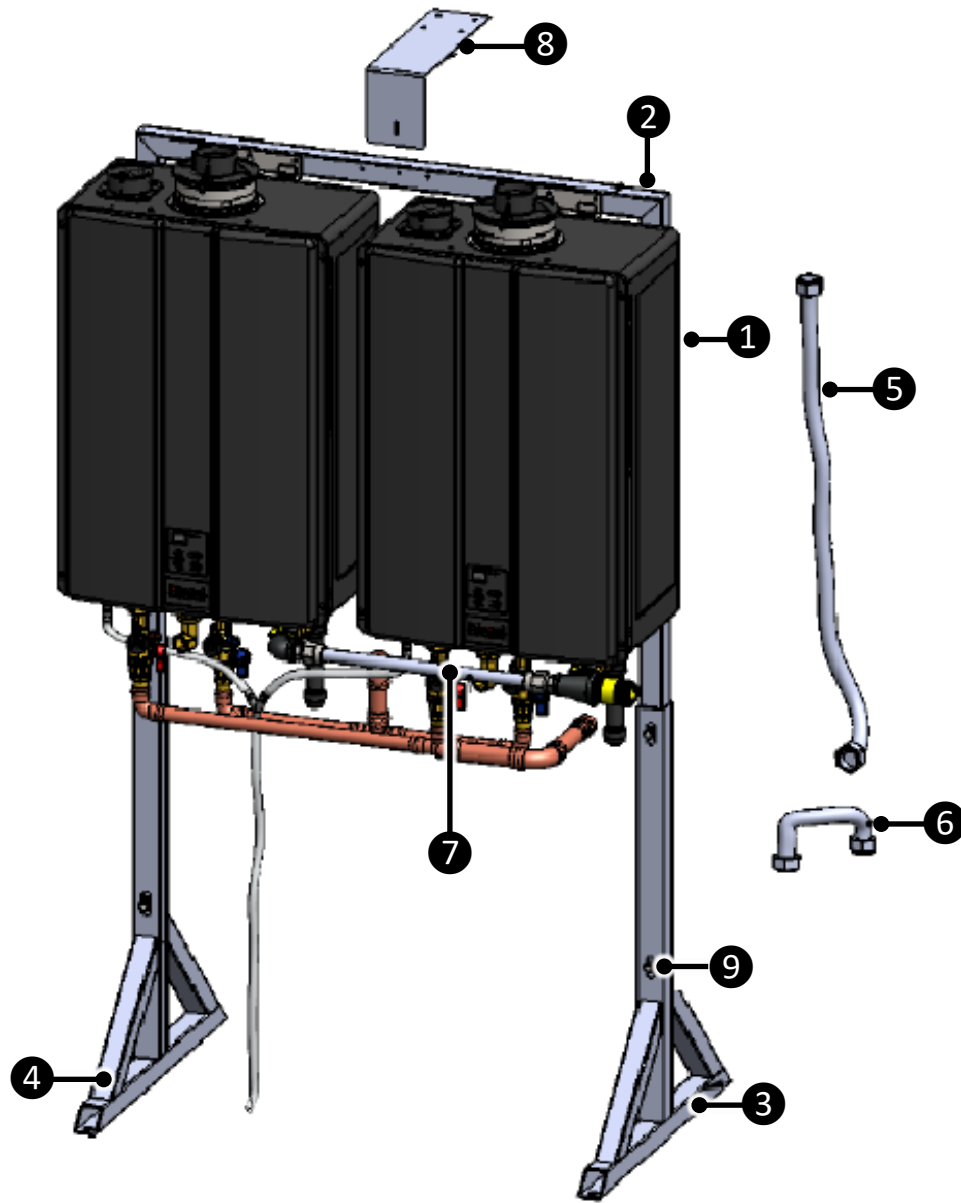

| ITEM NO. | PART # | DESCRIPTION |
|----------|-----------------|--------------------------------------|
| 1 | CU199IN/CU199IP | Rinnai SENSEI™ Tankless Water Heater |
| 2 | 109000478 | TRW02 Frame |
| 3 | 109000738 | Left Frame Base |
| 4 | 109000739 | Right Frame Base |
| 5 | 107000382 | 1 in. X 36 in. Water Flex Line |
| 6 | 107000383 | 1 in. X 12 in. Water Flex Line |
| 7 | 109000416 | Gas Flex Line |
| 8 | 109000830 | Top Support Bracket |
| 9 | 109000296 | 5/16 in.-18 Bolt |

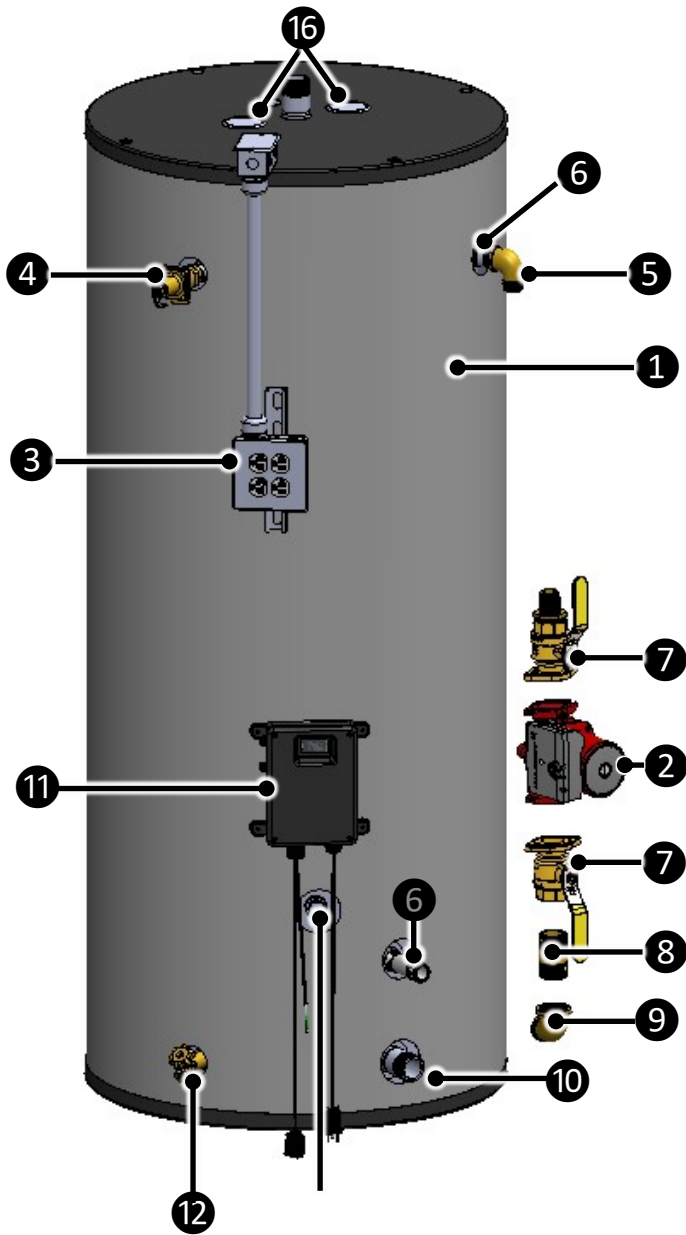

| ITEM NO. | PART # | DESCRIPTION |
|----------|-----------|---|
| 1 | 107000432 | 119-Gallon Tank |
| 2 | 107000377 | Grundfos UPS26-150(S)F Pump |
| 3 | 105000284 | 4-Unit Electrical Assembly |
| 4 | 107000437 | Temperature and Pressure (T&P) Relief Valve |
| 5 | 107000438 | 1 in. Street Elbow NPT |
| 6 | 107000440 | 1 in. X 3 in. Dielectric Nipple |
| 7 | 107000351 | Isolation Flange |
| 8 | 107000352 | 1-1/2 in. X 3 in. Brass Nipple |
| 9 | 107000353 | 1 in. X 1-1/2 in. Reducing Elbow |
| 10 | 107000308 | 1-1/2 in. X 4 in. Dielectric Nipple |
| 11 | 105000223 | DuoSmart™ Digital Controller |
| 12 | 107000315 | Brass Drain Valve 3/4 in. X 2-3/4 in. |
| 13 | 107000312 | Hand Hole Cleanout Cover |
| 14 | 109000633 | Cleanout Bolts 5/16 in.-18 X 3/4 in. |
| 15 | 107000311 | Tank Cleanout Flange Gasket |
| 16 | 107000314 | Anode Rod, Magnesium |

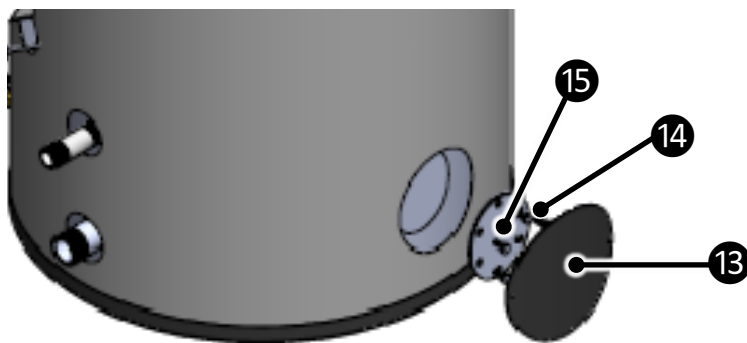

Limited Warranty for SE+ Series Models

- Internal (Indoor) Models: CU199i

What Is Covered?

The Rinnai Standard Limited Warranty covers any defects in materials or workmanship when the product is installed and operated according to Rinnai written installation instructions, subject to the terms within this Limited Warranty document. This Limited Warranty applies only to products that are installed correctly in the United States and Canada. Improper installation may void this Limited Warranty. It is recommended that a trained and qualified professional who has attended a Rinnai installation training class complete your installation. This Limited Warranty coverage, as set out in the table below, extends to the original purchaser and subsequent owners, but only while the product remains at the site of the original installation and terminates if the product is moved or reinstalled at a new location.

| Item | Warranty Coverage |
|--------------------------------|-------------------|
| Heat Exchanger* | 8 Years |
| Storage Tank | 6 Years |
| All Other Parts and Components | 5 Years |
| Reasonable Labor | 1 Year |

*The heat exchanger warranty will be 8 years or 12,000 operation hours, whichever occurs first.

The integrated controller has a 1 year warranty.

What Will Rinnai Do?

Rinnai will repair or replace the covered product or any part or component that is defective in materials or workmanship as set forth in the above table. Rinnai will pay reasonable labor charges associated with the repair or replacement of any such part or component during the term of the labor warranty period. All repair parts must be genuine Rinnai parts. All repairs or replacements must be performed by a qualified professional who is properly trained to do the type of repair.

Replacement of the product may be authorized by Rinnai only at its sole discretion. Rinnai does not authorize any person or company to assume for it any obligation or liability in connection with the replacement of the product. If Rinnai determines that repair of a product is not possible, Rinnai may replace the product with a comparable product at Rinnai's sole discretion. The warranty claim for product parts and labor may be denied if a component or product returned to Rinnai is found to be free of defects in material or workmanship; damaged by improper installation, use or operation; or damaged during return shipping.

How To Obtain Service

For the name of a trained and qualified professional, please contact your place of purchase, visit the Rinnai website (www.rinnai.us), call Rinnai at 1-800-621-9419 or write to Rinnai at 103 International Drive, Peachtree City, Georgia 30269.

Proof of purchase is required to obtain warranty service. You may show proof of purchase with a dated sales receipt, or by registering within 30 days of purchasing the product. To register your Rinnai Tankless Water Heater, please visit www.rinnai.us. For those without internet access, please call 1-800-621-9419. Receipt of registration by Rinnai will constitute proof-of-purchase for this product. Registration of product installed in new home construction may be verified with a copy of the closing papers provided by the initial home buyer. However, registration is not necessary in order to validate this Limited Warranty.

What Is Not Covered?

This Limited Warranty does not cover any failures or malfunctions due to the following:

- Accident, abuse, or misuse
- Alteration of the product or any component part
- Misapplication of this product
- Improper installation (such as but not limited to)
 - Product being installed in a corrosive environment
 - Condensate damage
 - Improper venting
 - Incorrect gas type
 - Incorrect gas or water pressure
 - Absence of a drain pan under the appliance
- Improper maintenance (such as but not limited to scale build-up, freeze damage, or vent blockage)
- Incorrect sizing
- Any other cause not due to defects in materials or workmanship
- Problems or damage due to fires, flooding, electrical surges, freezing or any acts of God
- Any damage caused by poor water quality
- Operating the water heater with anything other than potable water at all times
- Force majeure

There is no warranty coverage on product installed in a closed loop application, commonly associated with space heating only applications.

This Limited Warranty does not apply to any product whose serial number or manufacture date has been defaced.

This Limited Warranty does not cover any product used in an application that uses chemically treated water such as a pool or spa heater.

Limitation on Warranties

No one is authorized to make any other warranties on behalf of Rinnai America Corporation. Except as expressly provided herein, there are no other warranties, expressed or implied, including, but not limited to warranties of merchantability or fitness for a particular purpose, which extend beyond the description of the warranty herein.

Any implied warranties of merchantability and fitness arising under state law are limited in duration to the period of coverage provided by this Limited Warranty, unless the period provided by state law is less. Some states do not allow limitations on how long an implied Limited Warranty lasts, so the above limitation may not apply to you.

Rinnai shall not be liable for indirect, incidental, special, consequential or other similar damages that may arise, including lost profits, damage to person or property, loss of use, inconvenience, or liability arising from improper installation, service or use. Some states do not allow the exclusion or limitation of incidental or consequential damages, so the above limitation may not apply to you.

This Limited Warranty gives you specific legal rights, and you may also have other rights which vary from state to state.

www.rinnai.us/warranty

Notes

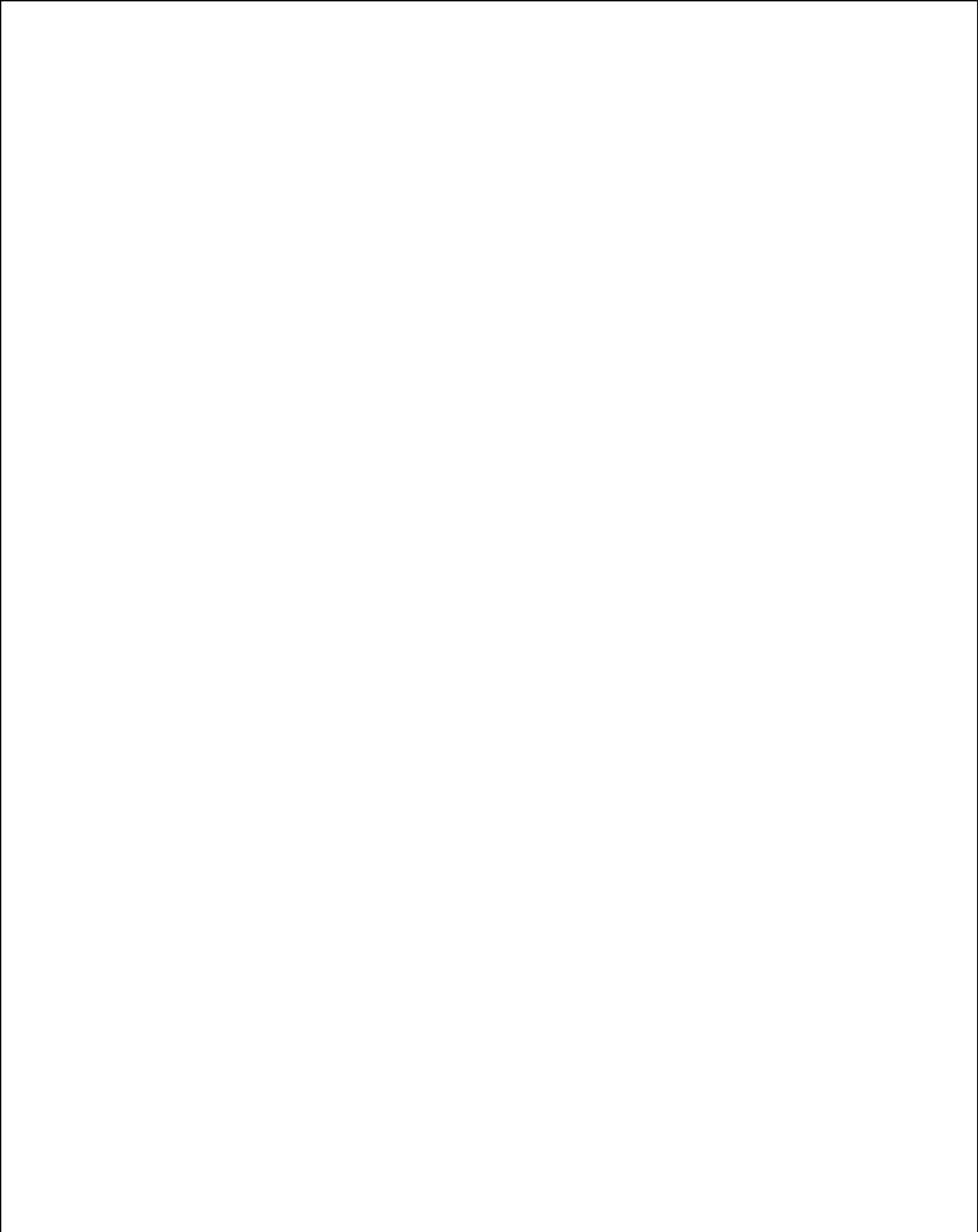
A large, empty rectangular box with a thin black border, occupying most of the page. It is intended for the user to write notes during the installation and operation of the Demand Duo™ 2 Commercial Hybrid System.

Notes

Notes

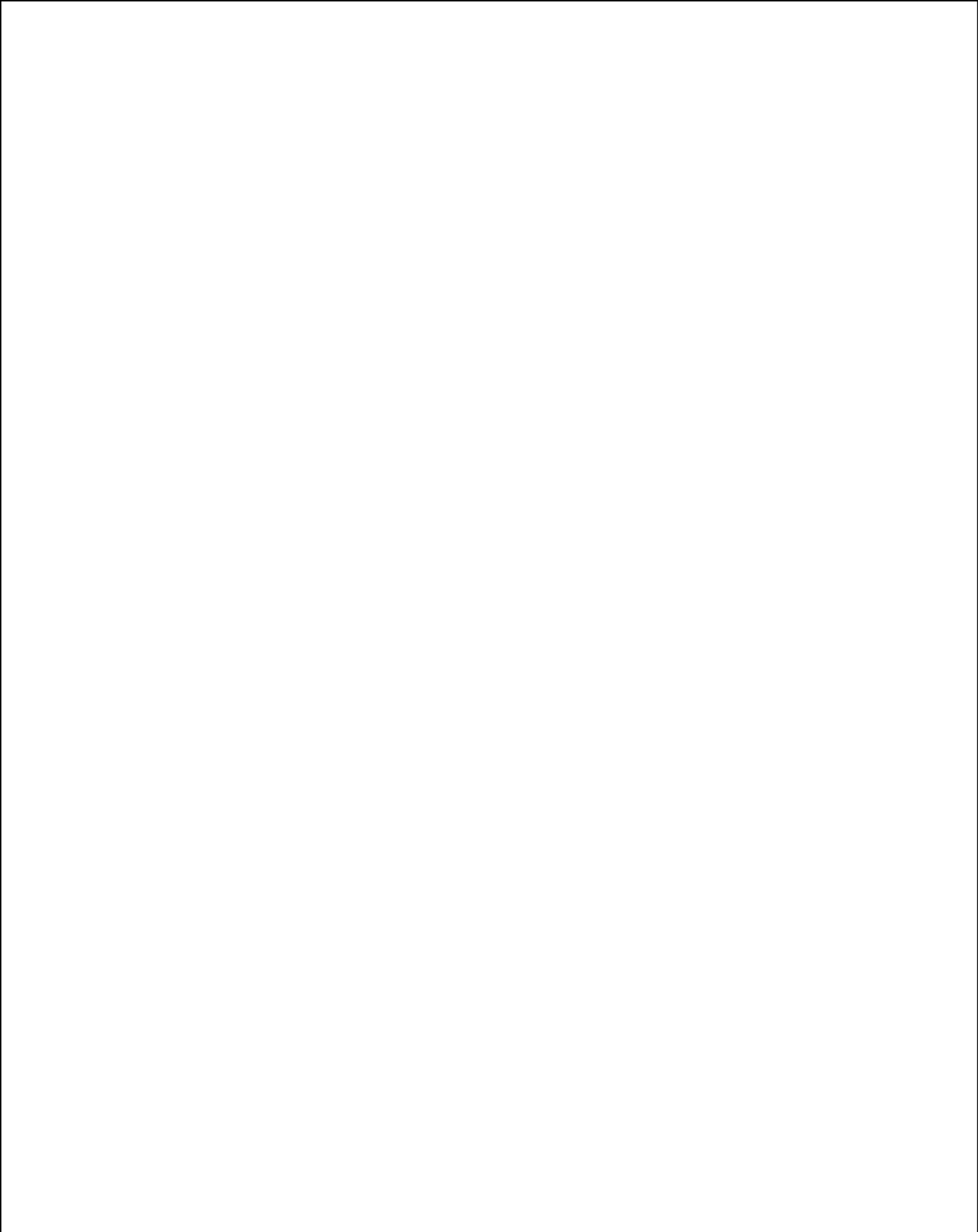



Learn more about Rinnai high-performance Tankless Water Heaters, Hybrid Water Heating Systems, Boilers, Vent-Free Fan Convectors and EnergySaver® Direct Vent Wall Furnaces at:

rinnai.us | rinnai.ca

Rinnai®

Rinnai America Corporation • 103 International Drive, Peachtree City, GA 30269
1-800-621-9419 • rinnai.us

©2020 Rinnai America Corporation. Rinnai America Corporation continually updates materials, and as such, content is subject to change without notice.

Local, state, provincial, federal and national fuel gas codes must be adhered to prior to and upon installation.

10000628(01)
3/2020