

# PERFORMANCE®



The new degree of comfort.®

## PERFORMANCE® Direct Vent gas water heaters are certified for Manufactured Housing (HUD) and modular construction

### Efficiency

- .57 - .59 UEF

### Performance

- FHR: 58 gallons for 40-gallon model and 46 gallons for 30-gallon model
- Recovery: 30.3 GPH a 90° F rise

### Flexibility

- Field convertible controls for natural gas or LP operation included
- No external door is required
- Hot water outlet located at top
- Cold water inlet at side for fast, economical hook-up

### Altitude Certification

- All models certified up to 5,999 feet above sea level

### Low Emissions

- Eco-friendly burner, low NOx design
- Meets 40 ng/J NOx requirements



#### Adjustable Roof Jack Vent

Design allows adjustment to roof pitches of up to 5/12". Four roof jacks available to accommodate roof thickness of 12" up to 95".

#### Direct Combustion Air Inlet

Air is drawn directly into combustion chamber through air inlet fixed to base; 1/2" screen for rodent protection.

#### Roof Jacks

12" Non-Adjustable & Air Inlet	AP12032E-1
15-32" Adjustable & Air Inlet	AP12032B-1
30-60" Adjustable & Air Inlet	AP12032C-1
48-95" Adjustable & Air Inlet	AP12032D-1

#### Air Inlets

6" Non-Adjustable	AP12019B
11-22" Adjustable	AP12017B

#### Extension Pipe Kit

Roof Jack Extension Pipe Kit	AP12021
------------------------------	---------

Roof jack and air inlet must be ordered separately with 30, 40 and 50-gallon direct vent models and must be in accordance with instructions furnished with the heater. No other roof jack or air inlet assemblies are approved for installation with this heater. Clamps and secure strapping are packed in water heater carton.

### Longer Life

- Premium grade anode rod provides long-lasting tank protection

### Plus...

- Piezo ignition – easy light pilot
- Factory installed temperature and pressure relief valve – side location
- Low lead compliant

### Warranty

- 6-Year limited warranty for tank and parts, 1-year full in-home labor warranty\*

\*See written warranty for complete details

Units meet or exceed ANSI requirements and have been tested according to D.O.E. procedures. Units meet or exceed the energy efficiency requirements of NAECA, ASHRAE standard 90, ICC Code and all state energy efficiency performance criteria.



**PERFORMANCE**  
**Direct Vent for**  
**Manufactured Housing**  
 30 and 40-Gallon Capacities  
 30,000 Btu/h  
 Natural Gas



See specifications chart on back.



The new degree of comfort®

## PERFORMANCE® Direct Vent Gas for Manufactured Housing Specifications

Fuel Type	Description	Nominal Gallon Capacity	Rated Gallon Capacity	Model Number	Gas Input in Thous. Btu/h	Recovery in G.P.H. 90° F Rise	First Hour Rating (Gallons)	Ht. to Vent A	Tank Height B	Diam. C	Ht. to Gas Conn. D	Vent Size E	Roof Jack Vent Size F	Ht. to Side T&P Valve G	Ht. to Water Conn. H	Ship Weight (LBS)	Uniform Energy Factor (UEF)
Natural Gas	Tall	40	38	XG40T06MD30U1	30	30.3	58	57-1/2	57-1/2	19-3/4	14-1/8	3	5	51-1/8	20	125	0.59
Natural Gas	Tall	30	29	XG30T06MD30U1	30	30.3	46	57	57	17-3/4	14-1/8	3	5	51-1/8	20	110	0.57

Uniform Energy Factor and rated gallon capacity based on Department of Energy (DOE) requirements.

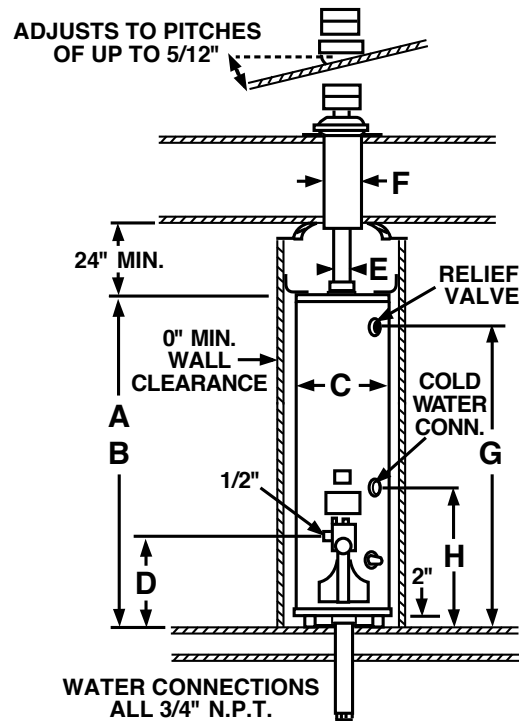

*In keeping with its policy of continuous progress and product improvement, Rheem reserves the right to make changes without notice.*

Rheem Water Heating • 1115 Northmeadow Parkway, Suite 100  
Roswell, Georgia 30076 • www.rheem.com