

## PRODUCT SUBMITTAL 578

**Product:** Turntable Uncoiler  
**Date:** 15 January 2019



Article No.	Description	Weight lb (kg)
424865-001	Turntable Uncoiler	88.5 (40.1)

### **FUNCTIONAL DESCRIPTION**

The Turntable Uncoiler has an adjustable I.D. to fit multiple sizes of PEXa, up to 1,000 ft of 3/4 in. Turntable rotates from horizontal to vertical to fit through doorways and allow for easy jobsite mobility. Assembly required.

For updates to this publication, visit [na.rehau.com/resourcecenter](http://na.rehau.com/resourcecenter)

The information contained herein is believed to be reliable, but no representations, guarantees or warranties of any kind are made as to its accuracy, suitability for particular applications or the results to be obtained therefrom. Before using, the user will determine suitability of the information for user's intended use and shall assume all risk and liability in connection therewith.

© 2019 REHAU

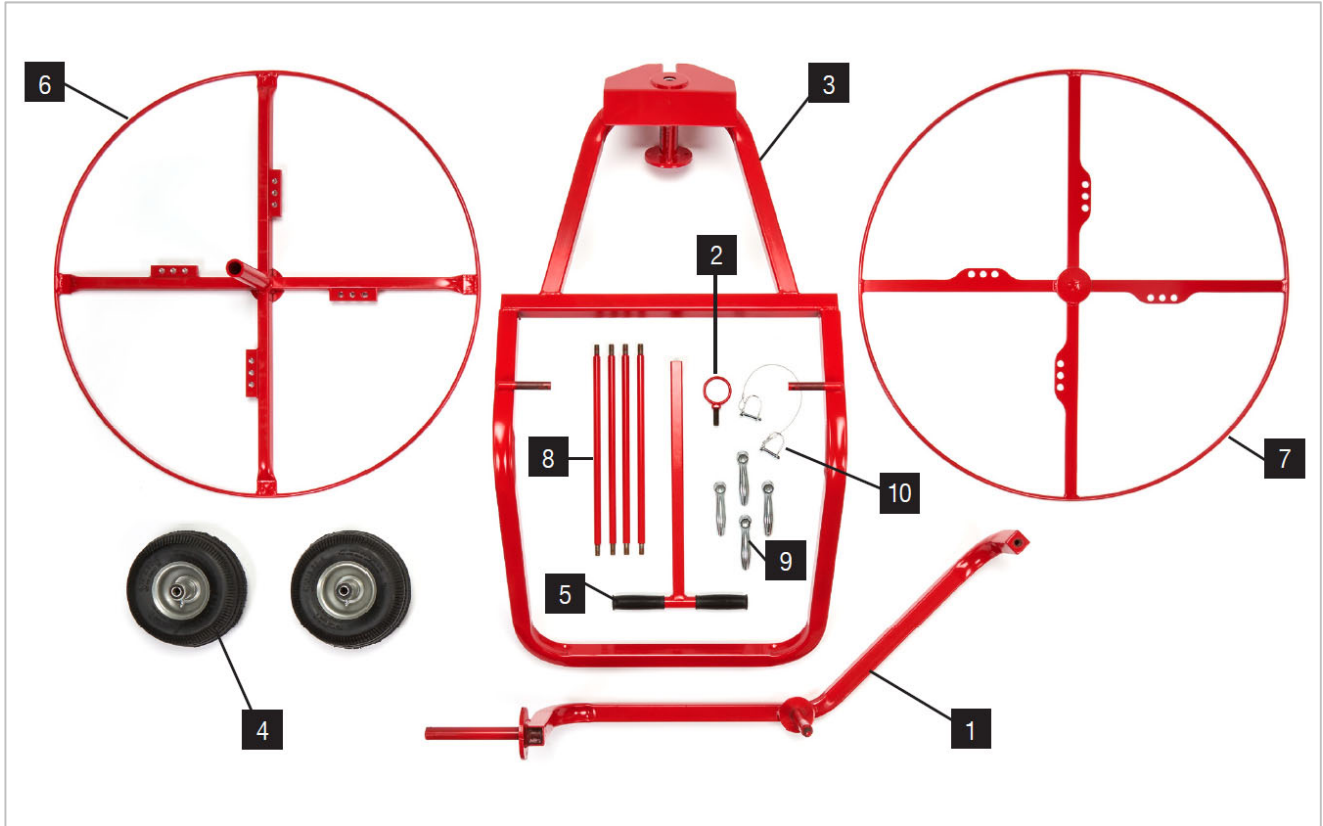

**SPARE PARTS LIST**

Item No.	Article No.	Description
1	424865-102	Reel Arm
2	424865-108	Pipe Guide
3	424865-101	Uncoiler Frame
4	424865-106	Wheel with Pneumatic Ties (set)
5	424865-107	Handlebar with Hand grips
6	424865-103	Reel Base
7	424865-105	Reel Cap
8	424865-104	Reel Hub Bar
9	424865-109	Handle Nut (1/2" -13)
10	424865-110	Tethered Hitch Pin (5/16" x 1 5/8")
	424865-111	CAUTION Label
	424865-112	Notice Label