

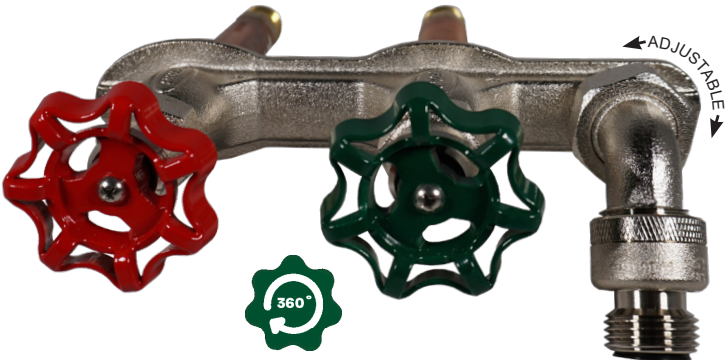

C-108/208 Hot & Cold Wall Hydrant



Vertical or Horizontal Installation

PRIER C-108 provides a year round source of tempered water in areas that are subject to freezing temperatures. The hydrant valve is connected to the supply piping in the heated portion of the structure, eliminating the possibility of freezing. Unique to its patented design, the same product can be installed horizontally or vertically. Ordering the C-208 gives you the same style hydrant but with vandal proof extended lockshields with operating key on both hot and cold stems.

The PRIER C-108 has all the characteristics of the historically proven C-134 with the added protection of a self-draining anti-siphon vacuum breaker and backflow check valve. It is available from stock in lengths from close coupled to 24". Longer sizes are available on request.



- Residential
- Freezeless
- Anti-Siphon
- Hot & Cold Mixing

C-208 Loose Key Design

FEATURES

- Horizontal or vertical installation options
- Anti-siphon aluminum vacuum breaker with EPDM back-flow preventer and backflow check valve
- Internal checks to prevent thermal migration
- Solid brass body, valve stem cap, seat and stem ends
- Satin nickel plated body maintains attractive finish
- Stainless steel screws
- Powder coated cast aluminum handle
- Lock shield cap
- AFG teflon with graphite packing for easy maintenance
- Standard "OO" size seat washer
- Each valve air-tested at factory for leak-free quality
- Spout aligning mark with manufacturer's date code

ORDERING

C-108D10

<p>Operator</p> <p>1- Handle Operated</p> <p>2- Vandal Proof Lockshield</p>	<p>Inlet</p> <p>D- 1/2" MPT x 1/2" SWT</p> <p>T- 3/4" MPT x 1/2" FPT</p> <p>C- 1/2" CPVC Glue-In</p> <p>S- 1/2" SWT x 3/4" Push-On</p> <p>F- 3/4" SWT</p> <p>G- 1/2" SharkBite Push-Fit</p> <p>Y- 1/2" Press-Fit</p> <p>X- 1/2" Crimp PEX</p> <p>W- 1/2" Wirsbo® PEX</p> <p>FX- 3/4" Crimp PEX</p> <p>FW- 3/4" Wirsbo® PEX</p>	<p>Length</p> <p>CC- Close Coupled</p> <p>04- 4" Insertion</p> <p>06- 6" Insertion</p> <p>08- 8" Insertion</p> <p>10- 10" Insertion</p> <p>12- 12" Insertion</p> <p>14- 14" Insertion</p> <p>16- 16" Insertion</p> <p>18- 18" Insertion</p> <p>20- 20" Insertion</p> <p>22- 22" Insertion</p> <p>24- 24" Insertion</p> <p>XX- Special Size</p>
--	---	---

INLET STYLES



C-108 REPLACEMENT PARTS

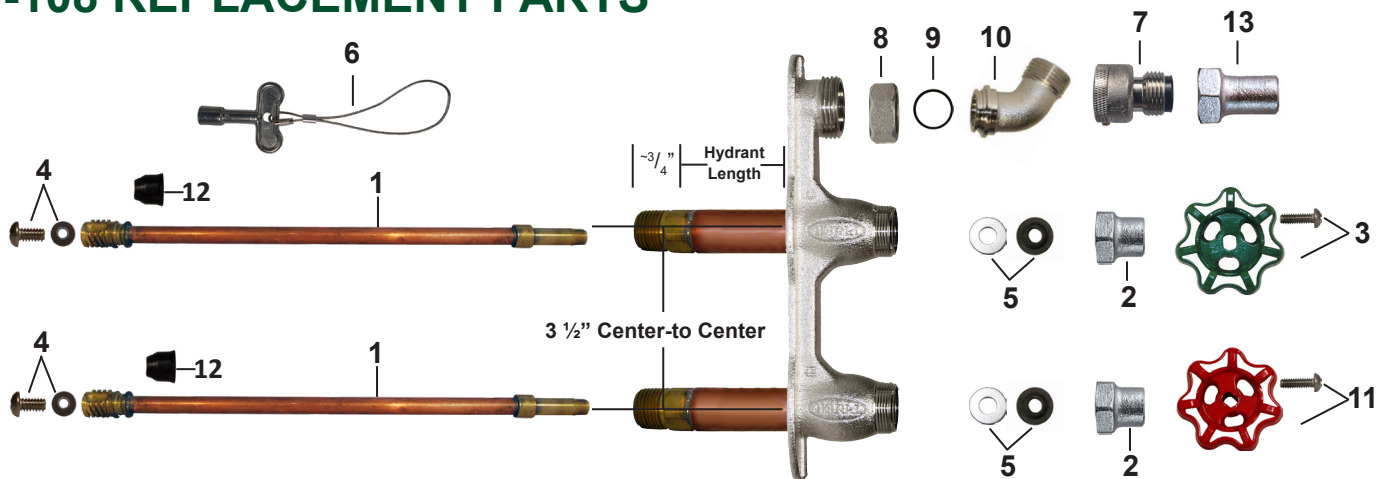

ID	Part No.	Description	ID	Part No.	Description
1	See Replacement Stem Section	Stem Assembly, Contains: 1, 4, 12	8	300-0030	Hose Thread Nut
2	300-1008	Valve Stem Cap	9	336-0005	O-Ring for Hose Thread Adapter
3	C-134KT-805	Oval Handle and Screw Kit (Green)	10	300-0029	Hose Thread Adapter
4	C-134KT-802	Seat Washer Kit (00 Beveled)	11	C-108KT-805	Red Handle and Screw Kit
5	C-134KT-803	Stem Packing Kit	12	336-0002	Backflow Check Valve for C-108
6	C-108KT-808	Loose Key on Lanyard	13	310-1015	Loose Key Valve Stem Cap
7	P-003NP	Replacement Vacuum Breaker		C-134KT-804	Loose Key Conversion Kit, Contains: 5, 6, 13

REPLACEMENT STEMS



G Style Manufactured April 2013 - Present

Part No.	Style	Description	Stem Length
P-231-12CC	G	Close Coupled Stem for C-108 Hydrant	4 ³ / ₈ " OAL
P-231-1204	G	Stem for 4" C-108 Hydrant	6 ⁷ / ₈ " OAL
P-231-1206	G	Stem for 6" C-108 Hydrant	8 ⁷ / ₈ " OAL
P-231-1208	G	Stem for 8" C-108 Hydrant	10 ⁷ / ₈ " OAL
P-231-1210	G	Stem for 10" C-108 Hydrant	12 ⁷ / ₈ " OAL
P-231-1212	G	Stem for 12" C-108 Hydrant	14 ⁷ / ₈ " OAL
P-231-1214	G	Stem for 14" C-108 Hydrant	16 ⁷ / ₈ " OAL
P-231-1216	G	Stem for 16" C-108 Hydrant	18 ⁷ / ₈ " OAL
P-231-1218	G	Stem for 18" C-108 Hydrant	20 ⁷ / ₈ " OAL
P-231-1220	G	Stem for 20" C-108 Hydrant	22 ⁷ / ₈ " OAL
P-231-1222	G	Stem for 22" C-108 Hydrant	24 ⁷ / ₈ " OAL
P-231-1224	G	Stem for 24" C-108 Hydrant	26 ⁷ / ₈ " OAL
P-231-02US	G	*Universal Replacement Stem for C-108 Hydrant	Up to 16 ⁷ / ₈ " OAL

*For stems manufactured before 2013, see C-108 Series retired style spec sheet at PRIER.com. PRIER universal stems are replacement stems for any size from close coupled to 14." The P-231-02US Universal Stem requires cutting the rod to proper length and soldering the brass stem end to the rod as directed in instructions.