

**Specification Submittal Data / Panasonic Range Hood**

**Description:**

Wall-mount chimney-style range hood provides superior capture efficiency. Quiet operation featuring HushFlow Technology. Stainless steel finish and washable and removable filter. LED lighting Must be available in 30" width\*. Range hood shall be certified by the Home Ventilating Institute (HVI), evaluated by Underwriters Laboratories and conform to both UL and cUL standards. Shall operate as stand alone or as part of the Cosmos Healthy Home System.

**Features:**

- Superior capture efficiency with 390 CFM and no need for make-up air\*\*. Capture efficiency plate velocity draws and eliminates contaminated air at the source.
- Exceptional quiet operation with HushFlow Technology which reduces noise up to 86%.
- Certified by the Home Ventilating Institute (HVI).
- Evaluated by Underwriters Laboratories and conforms to both UL and cUL standards.
- 2 LED lighting components.
- 3 continuous speeds and 1 boost speed.
- Electric touch control panel.
- Piston bar can protect the capture plate from sudden drop off.

- Filter maintenance sign function; alerts customer when filter needs to be cleaned.
- RoHs compliant.

**Motor/Blower:**

- AC Motor—2-pole condenser.
- Ventilation rates at 130-240-340-390 CFM.
- Power rating of 120 volts and 60 Hz.
- Motor equipped with thermal cutoff fuse and thermal protector.

**Housing:**

- Stainless steel (SUS304).

**Maintenance:**

- Removable and washable metallic grease filter (dishwasher safe).

**Warranty:**

- AC Motor: 3 years from original purchase date.
- ALL Parts: 3 Years from original purchase date.

**Architectural Specifications:**

30" Wall mount chimney style range hood. Range hood must be wall mounted. Must be HVI certified with <0.3 sones at low speed. Select from 130-240-340-390 CFM with <0.3/1.0/3.0/4.5 sones as certified by the Home Ventilating Institute (HVI). Range hood

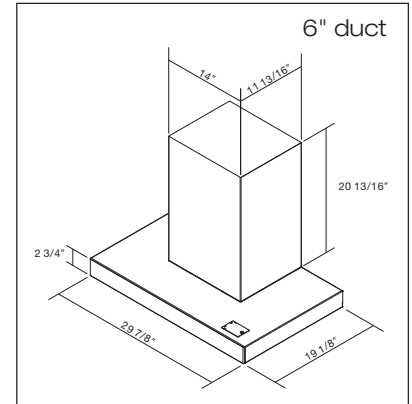

FV-30RCQL1

can be used to comply with ASHRAE 62.2 and CA Title 24. Shall be RoHs compliant. LED lighting. Power Consumption shall be no greater than 147.0/182.0/227.0/331.0 Watts. Energy efficiency of no less than 1.1/ 1.4/1.5/1.3 CFM/Watt. AC motor. Power Rating shall be 120v/60Hz.

Specifications: <b>WhisperHood IAQ</b> FV-30RCQL1		6" Duct				
	Speed	Boost Speed	High Speed	Middle Speed	Low Speed	Working Speed
<b>Range Hood Characteristics</b> (HVI Certified Data)	Static Pressure in inches w.g.	0.1	0.1	0.1	0.1	0.024
	Air Volume (CFM)	390	340	240	130	150
	Noise (sones)	4.5	3.0	1.0	<0.3	<0.3
	Power Consumption (watts)	331.0	227.0	182.0	147.0	146.0
	Energy Efficiency (CFM/Watt)	1.3	1.5	1.4	1.1	1.2
	Speed (RPM)	2483	2022	1550	1172	1087
	Amps (current)	2.81	2.15	1.79	1.47	1.47
	MAX. Amps (current)	2.81				
	Power Rating (V/Hz)	120/60				

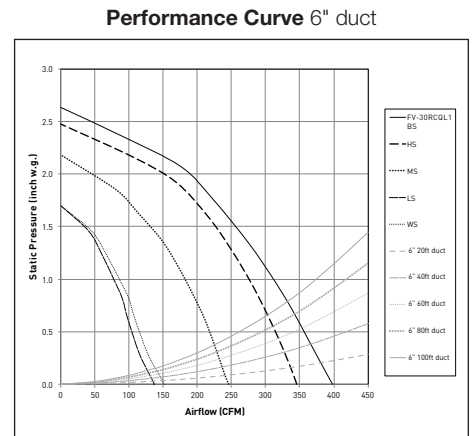

\*Available in 36" width, Island style.

\*\*The 390 CFM exhaust rate means that you do not have to add a make-up air system to comply with the 2015 IRC requirement (make-up is required if >400 CFM)

For complete Installation Instructions visit [us.panasonic.com/ventfans](http://us.panasonic.com/ventfans)

Model	Quantity	Comments	Project:
			Location:
			Architect:
			Engineer:
			Contractor:
			Submitted by:
			Date:

**Panasonic Life Solutions Company of America**  
**IAQ Division**  
Two Riverfront Plaza  
Newark, NJ 07102

WhisperhoodIAQ.com

