

BUILDER SERIES

Oasis

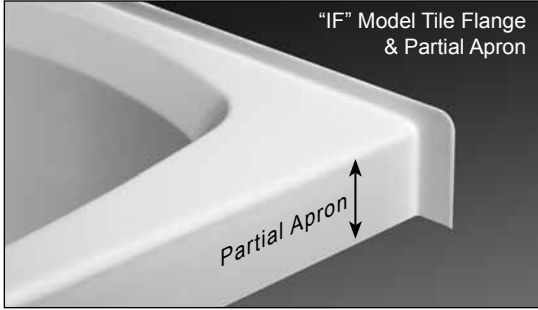

Home Innovation
LAB CERTIFIED™



66-INCH WIDE MODELS

Prestige 3466 (Tile Flange)

Rough-In Dimensions TR-S-220 66" wide x 35-1/2" deep x 22-1/4" high
 TR-IF-220

Finished Dimensions TR-S-220 66" wide x 34-1/4" deep x 21" high
 TR-IF-220

Unit Features

- Vacuum Formed Acrylic
- 2" Dia. RH or LH Drain (see reverse side for location)
- 2-1/2" Dia. Overflow (see reverse side for location)
- Twin, Contoured Armrests
- "S" Model: Integral Tile Flange & Full Apron
- "IF" Model: Integral Tile Flange & Partial Apron
- Pre-Leveled Block Base System
- Balsa Wood Core Floor Structure
- Textured Floor Pattern

Special Notes

- Whirlpool System Available (see reverse side for details)
- Air System Available (see reverse side for details)
- UL Listed Whirlpool & Air Systems
- Removable Access Panel Included on "S" Model w. System
- Model Available In Self-Rimming Design

Unit / System Order Number

Acrylic: TR-S-220 R or L Drain / 0ND (soaking tub)
 TR-S-220 R or L Drain / 6P (Builder System)
 TR-S-220 R or L Drain / CWS (Carress System)
 TR-S-220 R or L Drain / AR2 (Revive Air System)

Unit / System Order Number

Acrylic: TR-IF-220 R or L Drain / 0ND (soaking tub)
 TR-IF-220 R or L Drain / 6P (Builder System)
 TR-IF-220 R or L Drain / CWS (Carress System)
 TR-IF-220 R or L Drain / AR2 (Revive Air System)

System Trim

Standard 6P & CWS Trim (order code): White trim on White unit (WHT) - Biscuit trim on Biscuit unit (BSC)

Order Number / Description

CWS: *Carress System* includes: 4-Adjustable side jets, 2-rotating foot jets, 2-micro pulse back jets, variable flow control, twin air controls, electronic system control, 13.0 amp pump/motor, and a removable access panel (S model).

Options: In-Line Heater (1*) (order: ILH)
 Ozone Generator (1*) (order: OZG)
 Chromatherapy Pkg (1*, 2*) (order: CLT)
 Water Level Sensor (1*, 2*) (order: LWV)
 Trim Upgrade (1*)
 Chrome (order: CWS-CHR)
 Brushed (Satin) Nickel (order: CWS-SNK)

Order Number / Description

6P: *Builder System* includes: 6-Adjustable jets, twin air controls, pneumatic system control, 5.50 amp pump/motor, and a removable access panel (S model).

Options: In-Line Heater (1*) (order: ILH)
 Ozone Generator (1*) (order: OZG)

AR2: *Revive Air System* (3*) includes: (49) Perimeter air ports, electronic system control, 12.0 amp, 600-watt blower with ceramic heater, and a removable access panel (S model).

Notes: (1*) Factory installed options
 (2*) Includes system control upgrade
 (3*) Available on acrylic models only

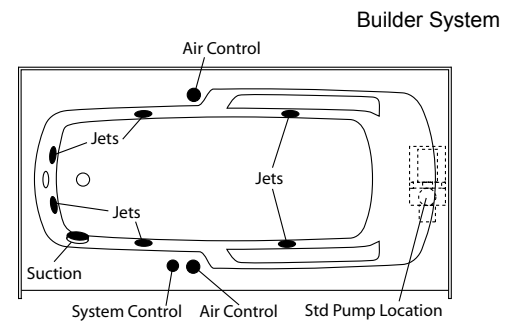
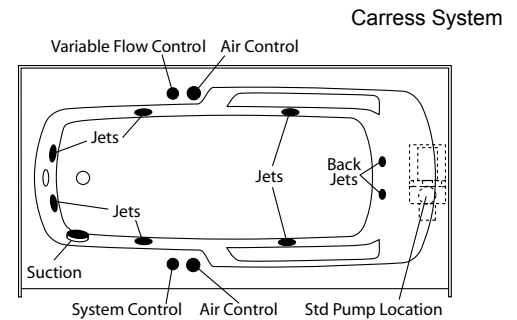
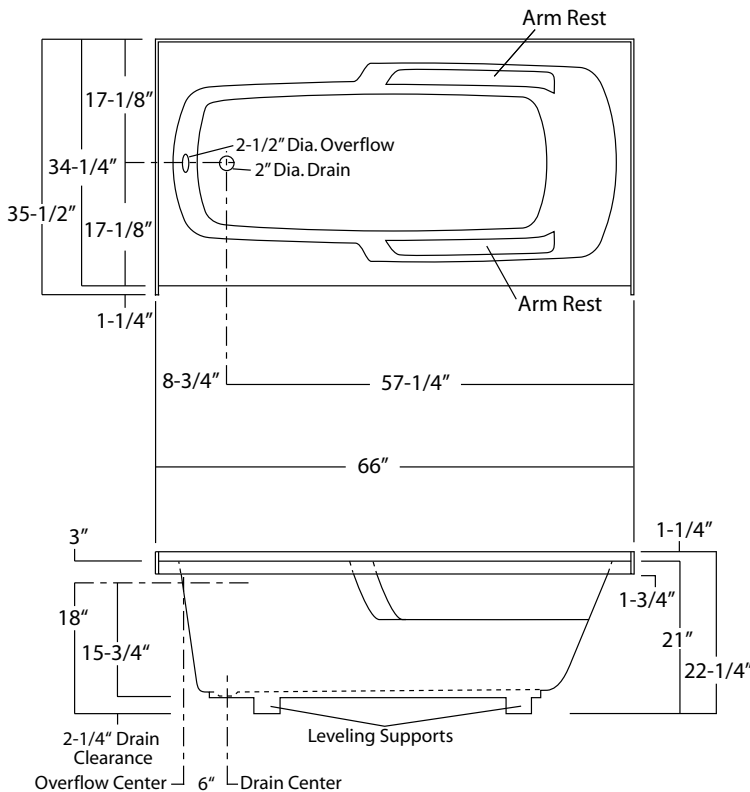

Revive Aire System

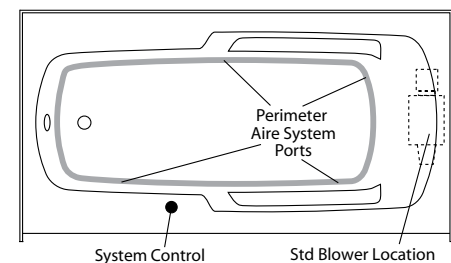

Prestige 3466: TR-IF-220L (illustrated)
 (S model full apron extends down to room floor)
 Sump Dimen: 53" long x 20-1/2" wide x 17-3/4" deep
 Sump Capacity: 57 gal. (unoccupied - to overflow)
 Whirlpool Operating: 26 gal.

Photographic images may include optional components and appear different than actual product.
 Dimensions shown are maximum. Due to the nature of the materials involved, actual unit dimensions can vary (tolerances: +/-1/8 inch)
 Oasis reserves the right to modify or discontinue product and/or associated equipment without prior written or verbal notification or obligation.