

# BUILDER SERIES

**Oasis**

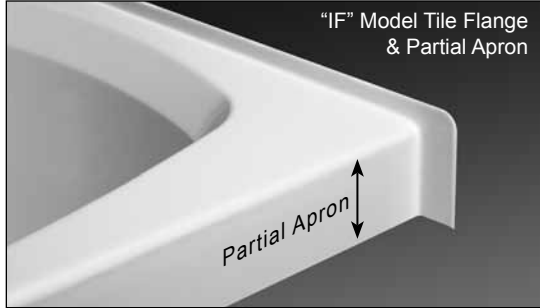

**Home Innovation**  
LAB CERTIFIED™



72-INCH WIDE MODELS

**Futura 4272 (Tile Flange)**

Rough-In Dimensions      OV-S-320      72" wide x 43-1/4" deep x 22" high  
    OV-IF-320

Finished Dimensions      OV-S-320      72" wide x 42" deep x 20-3/4" high  
    OV-IF-320

**Unit Features**

**Special Notes**

- Vacuum Formed Acrylic
- 2" Dia. Front Center Drain (see reverse side for location)
- 2-1/2" Dia. Overflow (see reverse side for location)
- "S" Model: Integral Tile Flange & Full Apron
- "IF" Model: Integral Tile Flange & Partial Apron
- Removable Apron Access Panel Included on "S" Model
- Pre-Leveled Block Base System
- Balsa Wood Core Floor Structure
- Textured Floor Pattern

- Whirlpool System Available (see reverse side for details)
- Air System Available (see reverse side for details)
- UL Listed Whirlpool & Air Systems
- Model Available In Self-Rimming Design

**Unit / System Order Number**

Acrylic:    OV-S-320 / 0ND (soaking tub)  
                  OV-S-320 / 6P (Builder System)  
                  OV-S-320 / CWS (Carress System)  
                  OV-S-320 / AR2 (Revive Air System)

**Unit / System Order Number**

Acrylic:    OV-IF-320 / 0ND (soaking tub)  
                  OV-IF-320 / 6P (Builder System)  
                  OV-IF-320 / CWS (Carress System)  
                  OV-IF-320 / AR2 (Revive Air System)

**System Trim**

Standard 6P & CWS Trim (order code):    White trim on White unit (WHT) - Biscuit trim on Biscuit unit (BSC)

### Order Number / Description

CWS: *Carress System* includes: 4-Adjustable side jets, 2-rotating foot jets, 2-micro pulse back jets, variable flow control, twin air controls, electronic system control, 13.0 amp pump/motor, and a removable access panel (S model).

Options: In-Line Heater (1\*) (order: ILH)  
 Ozone Generator (1\*) (order: OZG)  
 Chromotherapy Pkg (1\*, 2\*) (order: CLT)  
 Water Level Sensor (1\*, 2\*) (order: LWV)  
 Trim Upgrade (1\*)  
 Chrome (order: CWS-CHR)  
 Brushed (Satin) Nickel (order: CWS-SNK)

### Order Number / Description

6P: *Builder System* includes: 6-Adjustable jets, twin air controls, pneumatic system control, 5.50 amp pump/motor, and a removable access panel (S model).

Options: In-Line Heater (1\*) (order: ILH)  
 Ozone Generator (1\*) (order: OZG)

AR2: *Revive Air System* (3\*) includes: (57) Perimeter air ports, electronic system control, 12.0 amp, 600-watt blower with ceramic heater, and a removable access panel (S model).

Notes: (1\*) Factory installed options  
 (2\*) Includes system control upgrade  
 (3\*) Available on acrylic models only

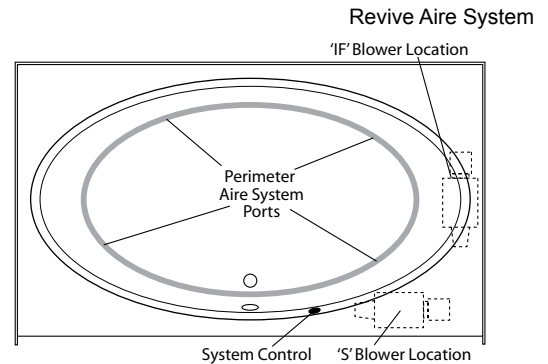
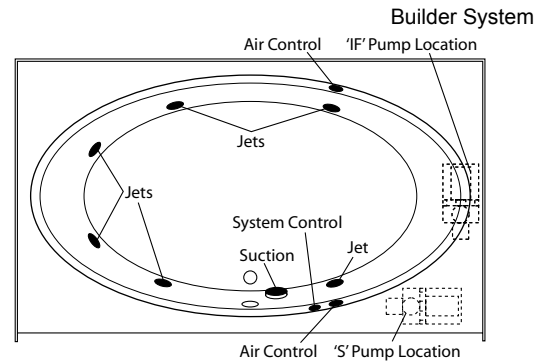
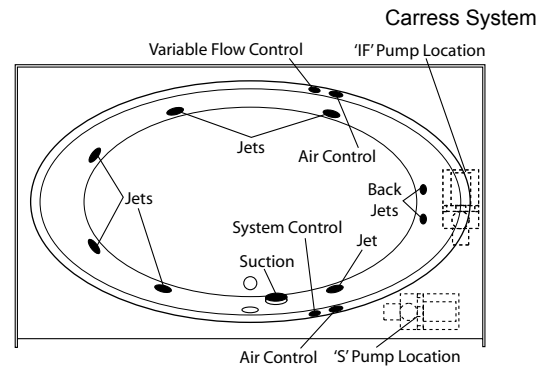
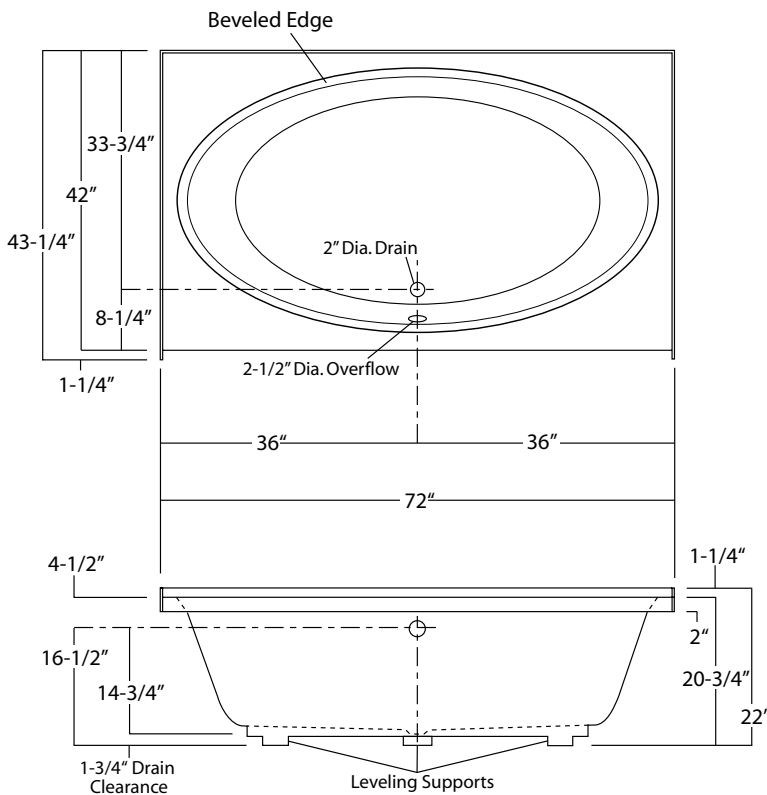

Futura 4272: OV-IF-320L (illustrated)  
 (S model full apron extends down to room floor)  
 Sump Dimen: 56" long x 33" wide x 18-1/4" deep  
 Sump Capacity: 89 gal. (unoccupied - to overflow)  
 Whirlpool Operating: 59 gal.

Photographic images may include optional components and appear different than actual product.  
 Dimensions shown are maximum. Due to the nature of the materials involved, actual unit dimensions can vary (tolerances: +/-1/8 inch)  
 Oasis reserves the right to modify or discontinue product and/or associated equipment without prior written or verbal notification or obligation.