

## Self-Rimming Installations - Builder Series

Paradise Isle TR-B-900  
 Geneva 3260 TR-B-200/TRG-200  
 Geneva 3660 TR-B-240/TRG-240  
 San Salvador 2 TR-B-150  
 Prestige 3466 TR-B-220  
 Prestige 4272 TR-B-140

Andros Isle TR-B-400  
 Geneva 3672 TR-B-270/TRG-270  
 Vincennes 2 / HGG-490  
 Classic 4060 OV-B-340/OVG-340  
 Futura 4260 OV-B-310/OVG-310  
 Classic 4472 OV-B-380/OVG-380  
 Futura 4272 OV-B-320/OVG-320

# Oasis®



Paradise Isle / TR-B-900  
 Andros Isle / TR-B-400



Geneva 3260 / TR-B-200, TRG-200  
 Geneva 3660 / TR-B-240, TRG-240  
 Geneva 3672 / TR-B-270, TRG-270



San Salvador 2 / TR-B-150



Prestige 3466 / TR-B-220  
 Prestige 4272 / TR-B-140



Vincennes 2 / HGG-490



Classic 4060 / OV-B-340, OVG-340



Futura 4260 / OV-B-310, OVG-310



Classic 4472 / OV-B-380, OVG-380



Futura 4272 / OV-B-320, OVG-320

These guidelines are recommended for the proper installation of Oasis products. A careful review of these procedures (and any referenced publications) before starting is important in avoiding an improper assembly and/or installation.

NOTE: All illustrations in this publication are typical, and may appear different than the actual product. Optional items may also be shown that were not ordered on the product being installed.

**ON WHIRLPOOL EQUIPPED MODELS, A SEPARATE SET OF INSTRUCTIONS IS PACKED WITH THE UNIT FOR THE WHIRLPOOL SYSTEM. READ THEM BEFORE INSTALLING UNIT!**

### Special Notes to Installer

- ◆ LIFT UNIT ONLY BY THE OUTSIDE SHELL. DO NOT HANDLE BY SYSTEM PIPING OR COMPONENTS!
- ◆ It is the sole responsibility of the installer to determine the requirements necessary for compliance with all code requirements!
- ◆ All paperwork packaged with the product should be saved and presented to the home owner upon completion of the installation!

◆ All published product dimensions are for reference only. Any critical dimensions required for installation should be taken directly from the product being installed!

◆ Any independent modifications made to the product (or any options / accessories supplied) beyond those required for normal installation can void all warranties! (Refer to warranties for further information)

### INSPECTION GUIDELINES

Carefully check the unit upon receipt. Notify your supplier immediately if any questions or problems are encountered during this process.

**DO NOT INSTALL PRODUCT WITHOUT FIRST ADDRESSING QUESTIONS WHICH ARISE DURING THE INSPECTION!**

### Basic Module Check

- Check unit drain position for match to bathroom drain location.
- Check unit for surface damage.
- Check unit color for coordination to other bathroom fixtures.

### Whirlpool System Check

Assembly and operational instructions are included in a separate publication for all whirlpool and air equipped models.

- Check for proper trim color and system options.

### INSTALLATION SITE FRAMING

#### **WARNING!**

**Oasis self-rimming models ARE NOT designed for insertion into a pre-finished deck or platform. Any unit or system damage resulting from the 'drop-in' installation technique may void all warranties.**

When the installation involves a deck or platform area, framing and/or finishing the deck or platform is NOT RECOMMENDED until the unit has been secured in position.

NOTE: A pump access MUST BE PROVIDED for all whirlpool equipped units. Additional access may be required to comply with local codes.

NOTE: 'Wet-set' is not required to support the floor under an Oasis product due to the encapsulated Balsa wood construction.

### Rim-To-Wall Installation

Position the unit in the bath area with the rim edge against the wall framing. Check for any framing modifications which may be required to accommodate pipes or fittings on whirlpool equipped models.

With the unit properly positioned, check for the following items: (Illust. 1)

- Confirm the pre-leveled base blocks are resting flush on the floor
- Confirm drain position.
- Confirm the unit is level along each side and across each end.

If required, place material under the base blocks to maintain the unit in a level position. After leveling the unit, place a mark along the bottom edge of the unit rim at

each framing member. Remove the unit and apply a 3/4" rail to the framing, 1/16" below the rim mark on the framing (illust. 1). DO NOT install the 3/4" rail as a rim support.

After repositioning and re-leveling the unit, secure the base blocks to the floor by applying a bead of construction adhesive to the underside of each block (illust. 2).

**NOTE:** Any material placed under the base blocks to keep the unit level must be structurally sound and applied to ensure the unit's weight will be equally distributed over the entire base.

### Deck Surround Framing

With the unit secured to the floor structure, as shown in illustrations 1 and 2, the framework surrounding the unit can now be

constructed. Due to the design possibilities, it is impossible to provide exact guidelines for every type of installation.

The following guidelines apply to every self-rimming unit regardless of the installation configuration. A careful review of these guidelines before continuing is important in avoiding unnecessary problems resulting in an improper installation (illust. 3, 4, 5, & 6).

- All materials and construction techniques must comply with applicable codes for the installation site.
- All framing must be square, level, and adequately designed to provide the structural (weight bearing) support necessary for the areas use.
- Provide all access areas required to comply with applicable codes for the installation.

Geneva 3260 / TR-B-200, TRG-200

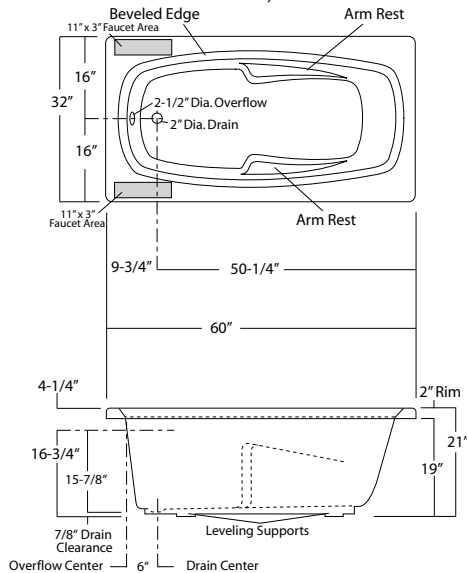

Geneva 3660 / TR-B-240, TRG-240

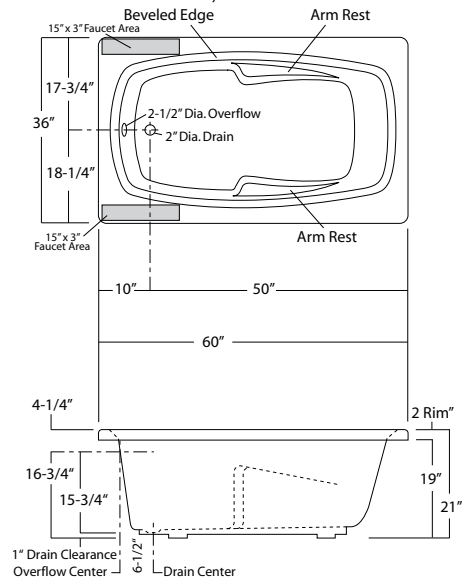

San Salvador 2 / TR-B-150

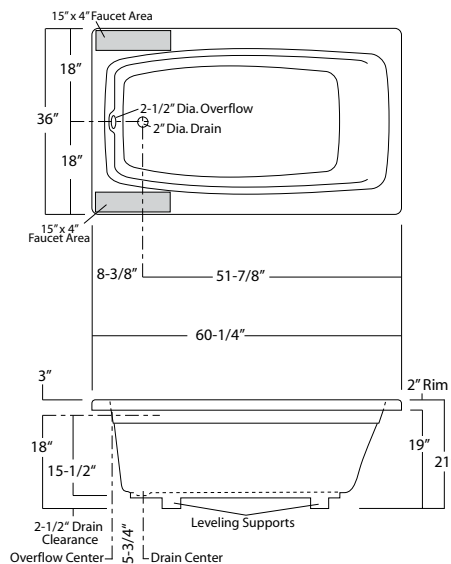

tion site. A service access is mandatory at the pump location on all whirlpool models for all installations (illust. 4).

- d) Appropriate clearances between the framing and the bottom edge of the rim must be maintained for the application of underlayment and the finish material, plus a 1/16" to 1/8" gap to allow for application of a waterproof sealant.

NOTE: Oasis recommends a high quality silicone based sealant with a mold and mildew resistant content.

**Deck Surround Finishing**

Install and seal an appropriate underlayment for the selected finish materials as instructed by the manufacturer. Make sure the underlayment extends under the tub rim far enough to provide adequate backing for the finish material (illust. 5).

Apply the finish material and seal according to the manufacturers specifications (illust. 5).

After all the finish work is completed, carefully clean the area and apply an appropriate waterproof sealant between the tub rim and the finish material. Consult the sealant container for application instructions (illust. 5).

**Rim-To-Wall Finishing**

Install and seal an appropriate underlayment to the wall framing for the selected finish material as instructed by the manufacturer. On rim-to-wall installations it is recommended that a double layer of underlayment be applied to insure the finish material edge will end above a flat unit surface (illust. 6).

Apply the finish material, leaving 1/16" to 1/8" clearance between the finish material

edge and the tub surface to allow for sealant application (illust. 6).

After all the finish work is completed, carefully clean the area and apply an appropriate waterproof sealant between the tub rim and the finish material. Consult the sealant container for application instructions (illust. 6).

**WARNING!**  
**THE INSIDE UNIT SURFACE SHOULD BE CLEAR OF ALL LOOSE DEBRIS AND THE SURFACE PROTECTED BEFORE STEPPING INSIDE.**

**Water Supply and Drain Connections**

Refer to, and follow, the assembly and installation instructions provided with the supply valves and drain system. Carefully check all connections for leaks.

Prestige 3466 / TR-B-220

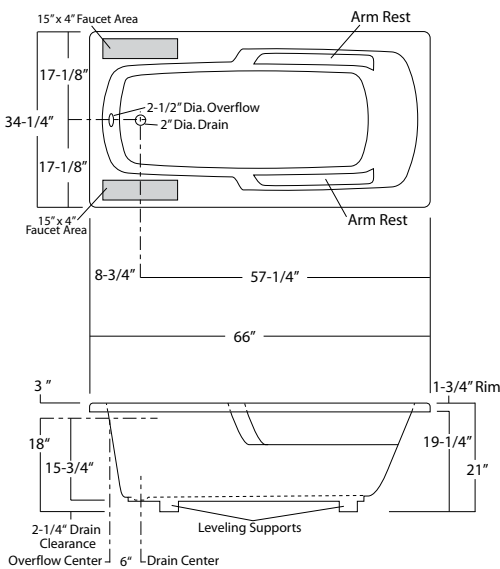

Prestige 4272 / TR-B-140

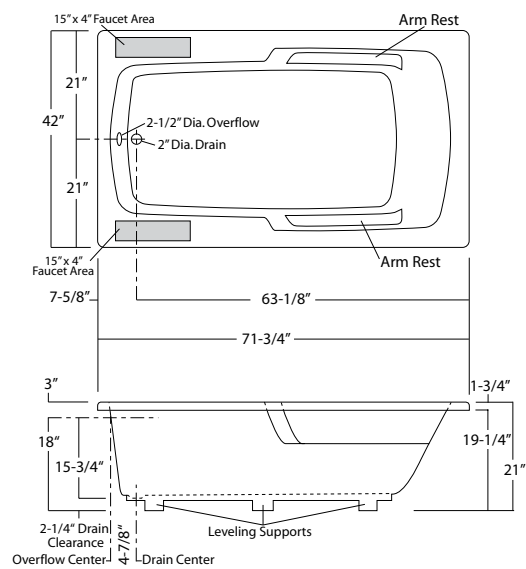

Paradise Isle / TR-B-900

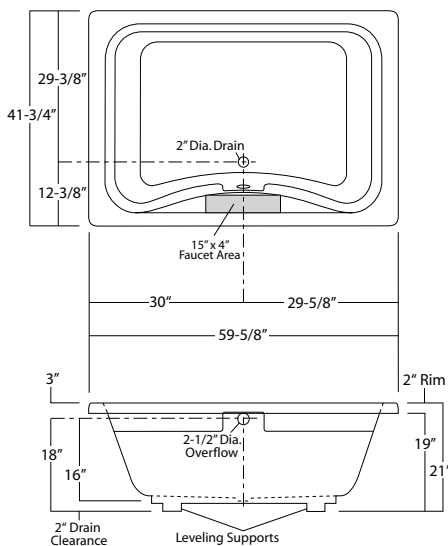

Andros Isle / TR-B-400

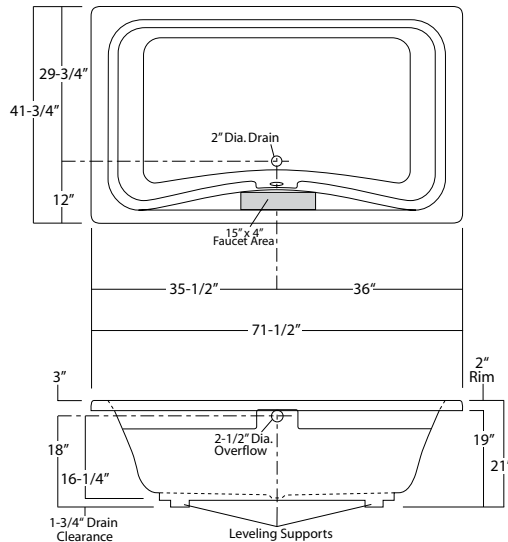

## UNIT SURFACE CARE

### **WARNING!**

**NEVER USE ABRASIVE MATERIALS,  
OR ABRASIVE CLEANERS  
ON THE UNIT SURFACE!**

**EXTREME CAUTION is urged regarding  
the use of any cleaner, acid or solvent  
on the unit surface.**

**READ AND FOLLOW PACKAGE  
INSTRUCTIONS FOR ALL  
PURCHASED CLEANING PRODUCTS!**

Through routine use the surface can collect residues from soap, bath additives and natural body oils. Additional deposits can also collect from minerals or particles found in the water. After each use, wipe the

excess water from the unit. This practice will reduce the buildup of deposits and help maintain the natural unit lustre.

Following a thorough surface cleaning, an application of quality automotive wax will help reduce major accumulations. The actual schedule for cleaning and waxing will depend on unit usage and water quality.

### **WARNING!**

**NEVER APPLY WAX TO THE FLOOR!**

◆ **Routine Cleaning:** Mild, non-abrasive cleaner specifically formulated for gelcoat and acrylic surfaces recommended. (Rinse surface thoroughly)

◆ **Heavy Soap Deposits:** Liquid ammonia household cleaner, applied full strength. (Rinse surface thoroughly)

◆ **Stubborn Stains:** Liquid household cleaner or hydrogen peroxide applied full strength. Place a saturated clean rag directly on stain and let stand several hours. (Rinse surface thoroughly)

◆ **Hard Water Scales:** Liquid scale remover or white vinegar, applied full strength. (Rinse surface thoroughly)

◆ **Mold/Mildew:** Liquid mildew remover or baking soda and water paste. (Apply paste and allow to fizz several minutes.) (Rinse surface thoroughly)

◆ **Construction Adhesive:** Soften with a hand held hair dryer and peel off adhesive. (Caution is advised when using any electrical device near water.)

Geneva 3672 / TR-B-270, TRG-270

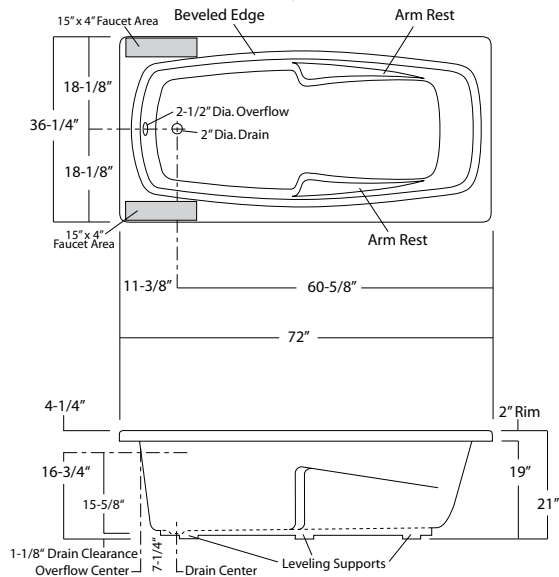

Vincennes 2 / HGG-490

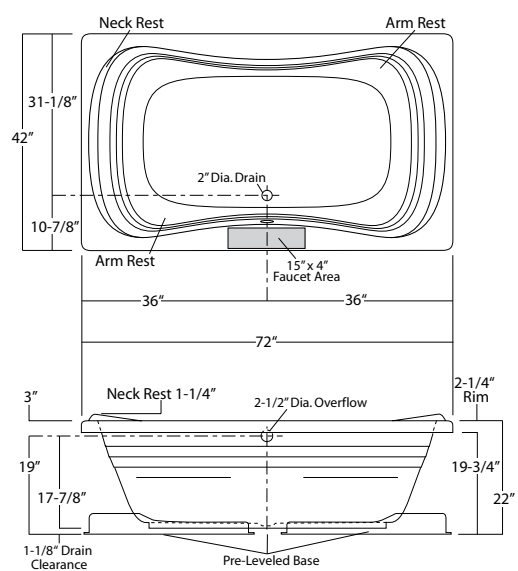

Classic 4060 / OV-B-340, OVG-340

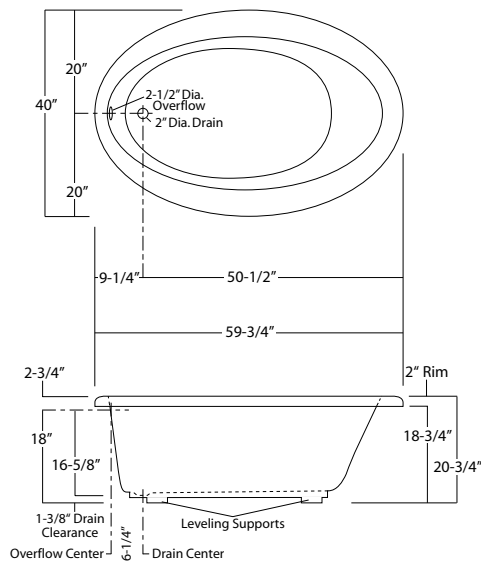

Futura 4260 / OV-B-310, OVG-310

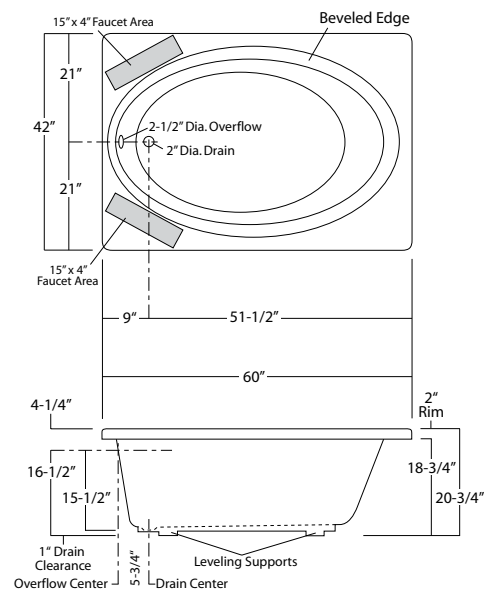

Classic 4472 / OV-B-380, OVG-380

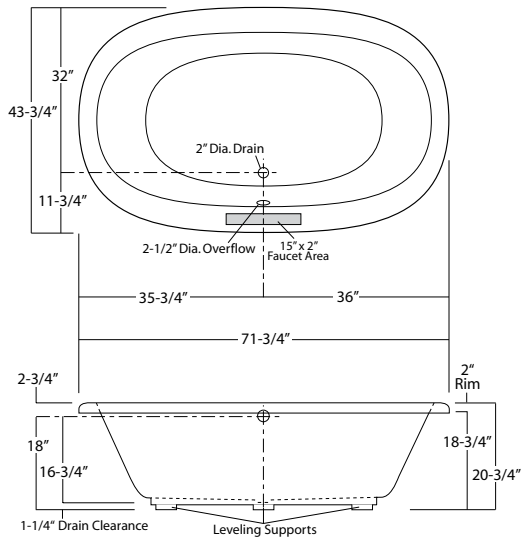

Futura 4272 / OV-B-320, OVG-320

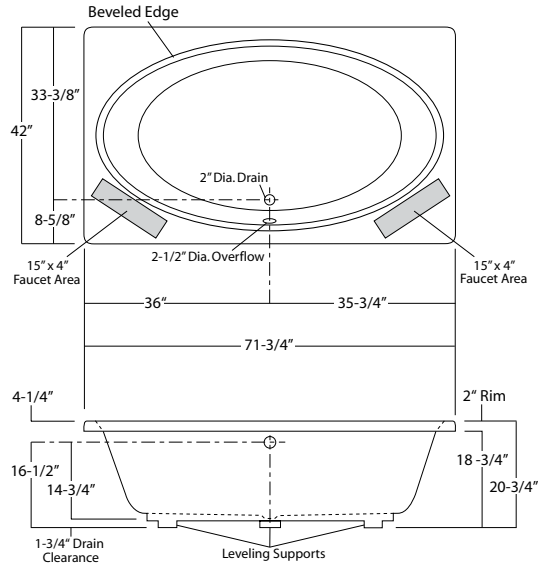

For adhesive residue, apply rubbing alcohol or nail polish remover, full strength. (Rinse surface thoroughly)

**WARNING!**  
**BATH MATS AND OTHER ITEMS HELD IN PLACE USING SUCTIONS MUST BE REMOVED FROM THE UNIT SURFACE AFTER EACH USE.**  
**OVER AN EXTENDED PERIOD. FAILURE TO REMOVE SUCTION ATTACHED ITEMS WILL DAMAGE THE UNIT SURFACE.**

4. Selective placement of framing members may be required to avoid damaging whirlpool system components.

1. The installation CANNOT allow the rim to support the weight of the unit.

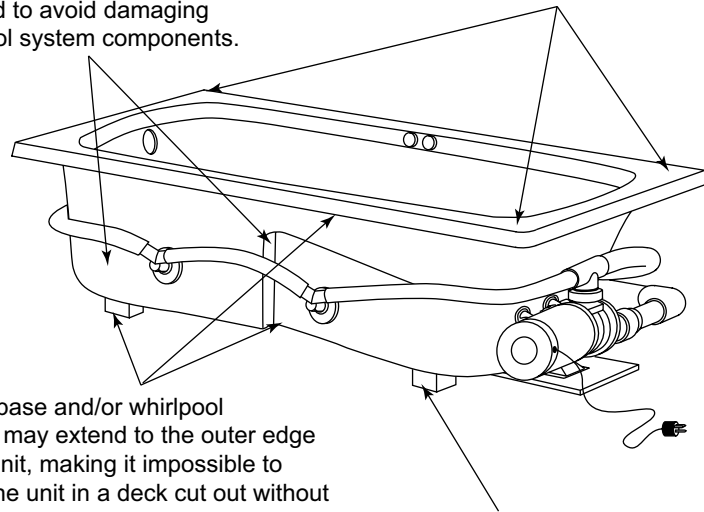

3. The base and/or whirlpool system may extend to the outer edge of the unit, making it impossible to insert the unit in a deck cut out without causing damage.

2. The factory-leveled block base MUST fully rest on the floor and be used as the unit support. Shimming of one or more blocks may be necessary to maintain level.

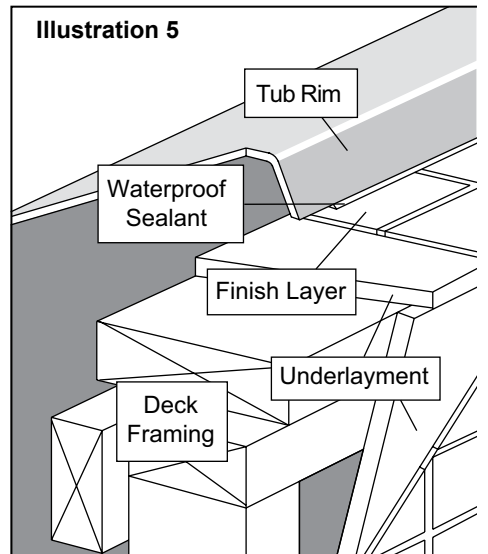
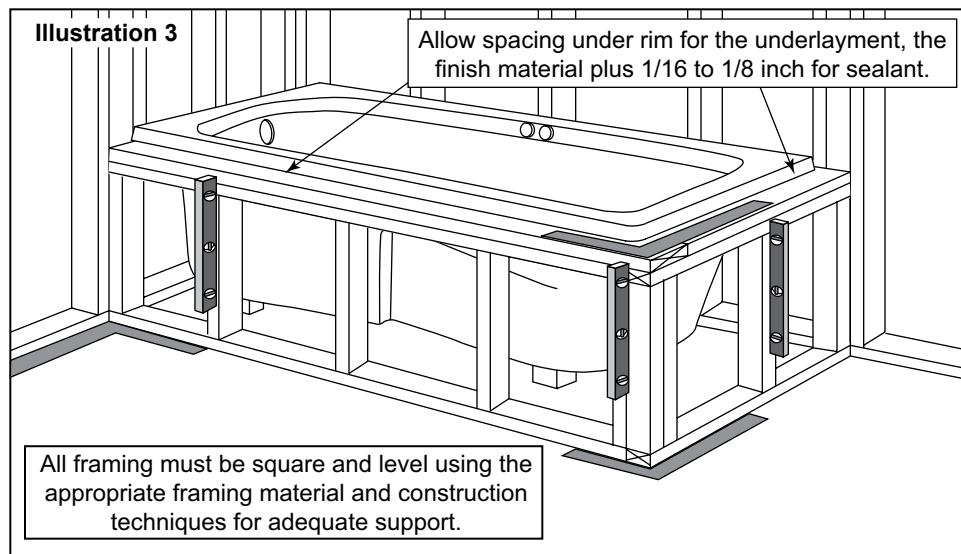
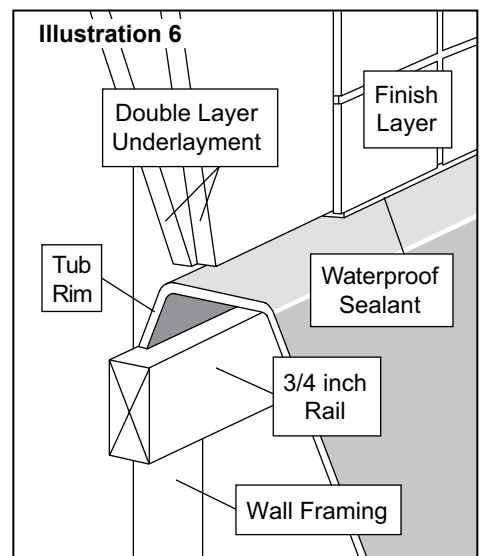
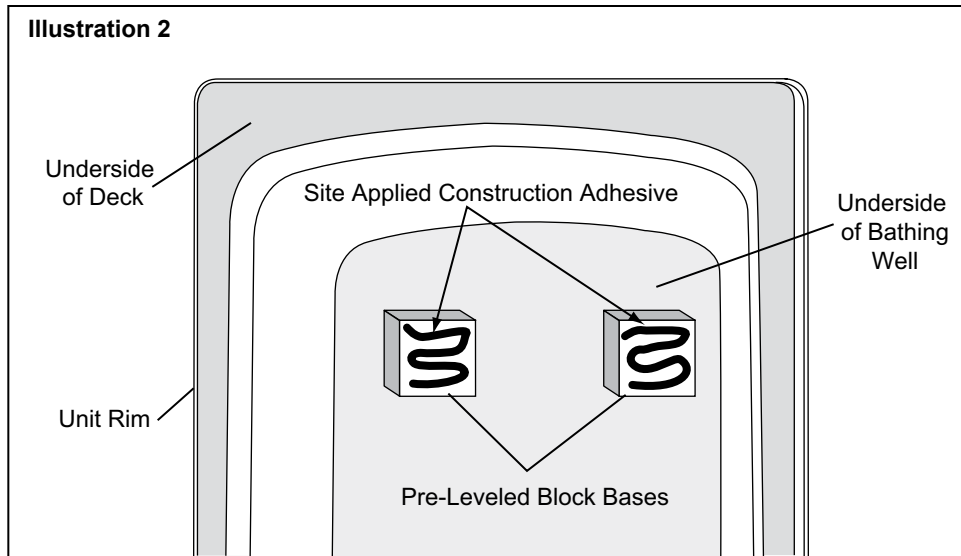
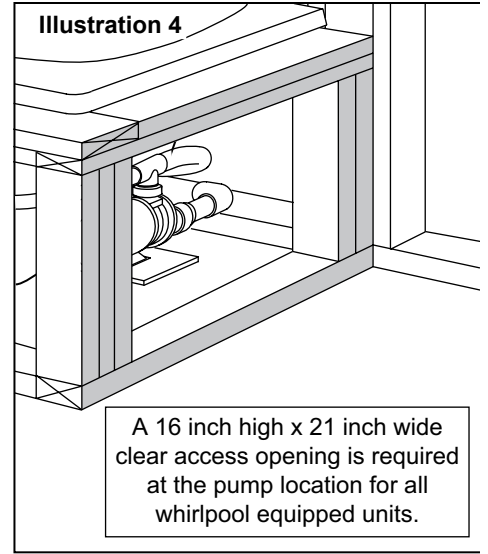
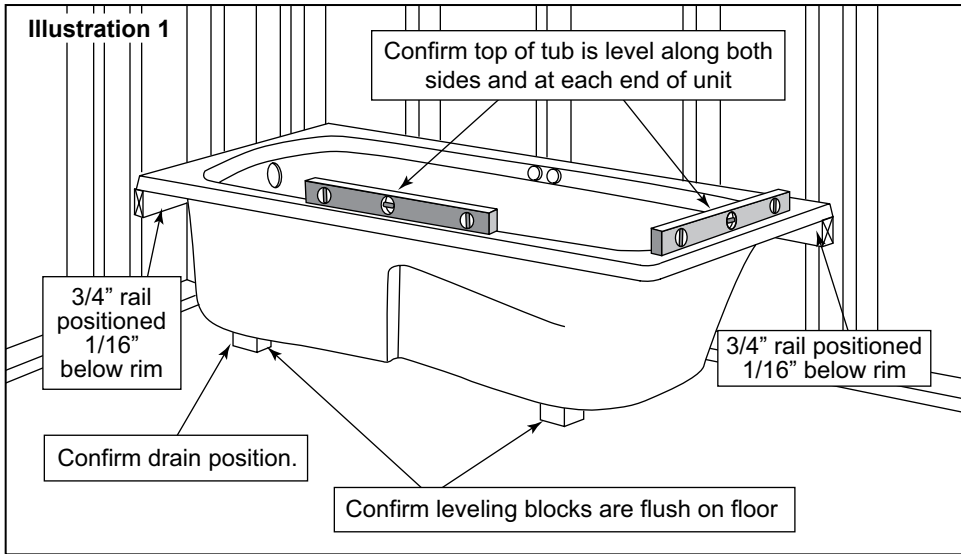



## Oasis Lifestyle Product Assurance Program

### **Bathing and Shower Unit Structure & Surface Finish Limited Warranty**

Oasis Lifestyle provides a performance assurance program for unit structural integrity and surface finish covering a five (5) year period from the date-of-purchase on GELCOAT, and covering a ten (10) year period from the date-of-purchase on VACUUM FORMED ACRYLIC product, for the original purchaser and subsequent consumer. This Oasis limited warranty program addresses specific defects in the product, and the workmanship associated with the manufacture of the Oasis bathing and shower product. The specific defects covered must result in a significantly altered appearance and/or affect the intended performance standards for the product under normal residential use.

### **Hydro-Massage Systems (water recirculation & air), Option & Accessories Limited Warranty**

Oasis Lifestyle provides a performance assurance program for their hydro-massage systems (herein called 'system'), and their options and accessories covering a two (2) year period from the date-of-purchase for the original purchaser and subsequent consumer. This Oasis limited warranty program addresses specific defects in the system components, and the workmanship associated with the assembly of the systems, along with offered options and accessories installed by Oasis, on an Oasis unit. The specific defects covered must result in a significantly altered appearance and/or affect the intended performance standards for the system, the option and/or the accessory.

During the coverage period, Oasis will, at its discretion (following a verification by an authorized Oasis representative), either provide service or supply a replacement product without charge, but excluding any cost associated with the transportation, removal of and/or reinstallation of the unit (module). Failure to allow requested inspection by an authorized Oasis representative, and/or failure to provide adequate accessibility for an authorized inspection, and/or service performed prior to documented authorization from Oasis Lifestyle, LLC., may delay service, and/or possibly terminate any warranty coverage, and remove any liability to Oasis Lifestyle, LLC.

#### **This 'Product Assurance Program' does not cover service resulting the following:**

- a) Improper field installation of the product, system, option, accessory, and/or surrounding structure modifications, and/or utility service connections beyond the recommendations supplied by Oasis and within the scope of applicable codes and ordinances; or
- b) Carelessness, damage, abuse, misuse, negligence, improper care, fire, flood, or acts of God; or
- c) Non-conforming use, including any use beyond those intended for the product, system, option and/or accessory, including failure to follow the Prescribed Care and Maintenance Instructions; or
- d) Any unauthorized alterations or modifications to the product, system, option, accessory and/or the individual parts or components supplied by Oasis.
- e) Any surface and/or component staining, discoloration, component failure and/or build-up caused as a result of water chemistry or water quality at the site.
- f) Service resulting from normal use and wear for the product, system, option and/or accessory.

Repair or the supplying of replacement product and/or components, under this limited warranty program, shall be the exclusive remedy. Oasis Lifestyle, LLC., shall not be liable for any incidental or consequential damages, including damages to the building / structure, the contents, the occupants, or breach of any expressed or implied warranties. Oasis Lifestyle, LLC., does not recognize, nor authorizes any party to provide implied or written warranties regarding a product, system, option and/or accessories fitness for a particular purpose, nor modify the terms of the limited warranty beyond those stated.

Some states do not allow the exclusion or limitation of incidental or consequential damages, or allow limitations on the duration of any implied warranty. Therefore, the above exclusions and/or limitations may not apply.

THIS WARRANTY PROVIDES SPECIFIC LEGAL RIGHTS, WHICH CAN VARY FROM STATE-TO-STATE.

