



BROAN® ERV250 ECM
Part no. ERV250TE
 50 to 241 CFM (0.4 in. w.g.)



VB0261

THE FUTURE OF FRESH AIR

The whole home ventilation system is a centerpiece of today's energy-efficient homes. Broan introduces its new HE Series that combines the best performance with the best energy efficiency to provide fresher, purer air in your home at a lower overall operating cost. That's Pure Efficiency.

The ERV250 ECM is the perfect solution for mid to large size homes in need for the most energy-efficient ventilation solution.

- Up to 241 CFM at 0.4 in. w.g.
- High efficiency energy recovery core with a sensible recovery efficiency of 75% at 32°F and 65% at -13°F
- ECM* motors
- Minimal power consumption of 18 W and 3.6 CFM/Watt at 64 CFM
- Merv 6 grade filters and optional HEPA filtration
- Electronic balancing and no balancing dampers
- Included wall mounting bracket.

*Electronically Commutated Motor.

REPAIRS AND MAINTENANCE

The ERV250 ECM high output ECM motors are permanently lubricated. The electronic circuit board eliminates electromechanical parts, reducing repair time to a minimum.

WARRANTY

The ERV250 ECM is protected by a 5-year warranty on parts only, except for the energy recovery core, which is covered by a 10-year warranty, with the original proof of purchase.

Available at:



*This product earned the ENERGY STAR® by meeting strict energy efficiency guidelines set by Natural Resources Canada and the EPA. It meets ENERGY STAR® requirements only when used in Canada.

ENERGY RECOVERY VENTILATOR

Controls

The exclusive VT9W main wall control, sold separately, is the only compatible wall control to be used with the ERV250 ECM.

At installation, use the VT9W main control to perform electronic balancing, without balancing dampers!

Optional auxiliary controls also available; for more details, refer to the User Guide - Main and auxiliary wall controls available at www.broan-nutone.com.

Option

HEPA Filter 21996

Additional 0.3 in. w.g. static pressure at highest speed to be considered. Refer to the HEPA filter instructions for more details.

Homeshield™ Defrosting System

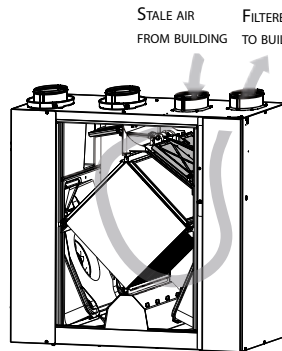

VF0064

The ERV250 ECM uses a unique defrosting method. No negative pressure is created by air exhausted to the outdoors, as the air is recirculated into the house, helping to prevent any backdraft.

Use the VT9W to choose one of the 3 defrost modes available, according to your needs:

- Standard (factory set regular mode)
- Plus (extended defrost for colder areas)
- Discretion (keeps the same speed when performing defrost as performing ventilation)

OUTDOOR TEMPERATURE*		DEFROST IN MINUTES / AIR EXCHANGE IN MINUTES					
		STANDARD		DISCRETION		PLUS	
°C	°F	CONTINUOUS MODE	TURBO FUNCTION	CONTINUOUS MODE	TURBO FUNCTION	CONTINUOUS MODE	TURBO FUNCTION
-27 and less	-17 and less	10/25	10/20	18/25	18/20	15/20	15/15
-20 to -27	-4 to -17	8/28	8/23	16/28	16/23	12/20	12/15
-15 to -20	5 to -4	8/35	8/30	16/35	16/30	10/25	10/20
-10 to -15	14 to 5	8/45	8/40	16/45	16/40	10/30	10/25
WARMER THAN -10	WARMER THAN 14	NO DEFROST					

*Outdoor temperature is read by a thermistor located inside the unit, next to fresh air from outside port.

Requirements and standards

- Complies with the UL 1812 requirements regulating the installation of Energy Recovery Ventilators
- Complies with the CSA C22.2 no. 113 Standard applicable to ventilators
- Complies with CSA F326 requirements regulating the installation of Energy Recovery Ventilators
- Technical data was obtained from published results of tests relating to CSA C439 Standards
- HVI certified and ENERGY STAR® qualified

DIMENSIONS: ERV250 ECM

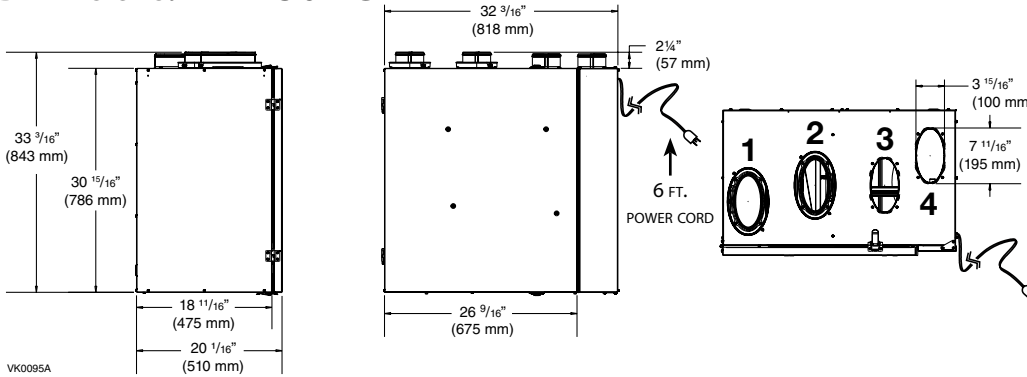

NOTE: ALL UNITS PORTS WERE CREATED TO BE CONNECTED TO DUCTS HAVING A MINIMUM OF 6" DIAMETER, BUT IF NEED BE, THEY CAN BE CONNECTED TO BIGGER SIZED DUCTS BY USING AN APPROPRIATE TRANSITION (E.G.: 6" DIAMETER TO 7" DIAMETER TRANSITION).

- 1: EXHAUST AIR TO OUTDOORS PORT
- 2: FRESH AIR FROM OUTDOORS PORT
- 3: EXHAUST AIR FROM BUILDING PORT
- 4: FRESH AIR TO BUILDING PORT

VENTILATION PERFORMANCE

EXTERNAL STATIC PRESSURE		NET SUPPLY AIR FLOW			GROSS AIR FLOW					
PA	IN. W.G.	L/S	CFM	M ³ /H	SUPPLY			EXHAUST		
					L/S	CFM	M ³ /H	L/S	CFM	M ³ /H
25	0.1	125	265	448	126	267	455	128	271	459
50	0.2	122	259	440	124	263	447	125	265	448
75	0.3	119	252	428	121	256	433	121	256	433
100	0.4	115	244	413	116	246	418	116	246	418
125	0.5	109	231	392	111	235	399	111	235	399
150	0.6	104	220	374	105	222	379	105	222	379
175	0.7	98	208	352	99	210	357	100	212	358
200	0.8	92	195	331	93	197	336	94	199	338
225	0.9	87	184	311	88	186	316	88	186	318
250	1.0	82	174	294	82	174	297	83	176	299
275	1.1	77	163	277	78	165	282	78	165	282

FAN CURVES ACCORDING TO SPEED

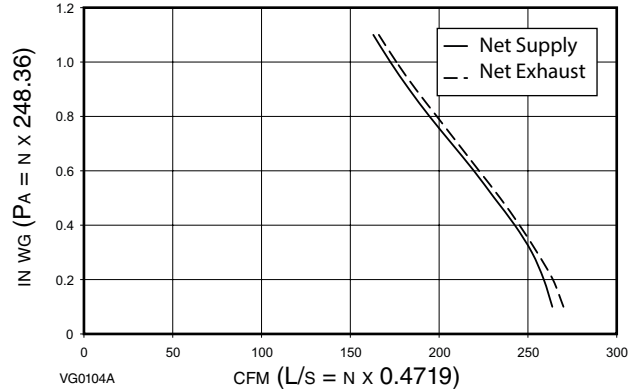

FULLY ADJUSTABLE SPEED RANGE FROM 50 CFM TO MAXIMUM SPEED.

ENERGY PERFORMANCE

SUPPLY TEMPERATURE		NET AIR FLOW			POWER CONSUMED WATTS	SENSIBLE RECOVERY EFFICIENCY	ADJUSTED SENSIBLE RECOVERY EFFICIENCY	APPARENT SENSIBLE EFFECTIVENESS*	LATENT RECOVERY/MOISTURE TRANSFER
°C	°F	L/S	CFM	M ³ /H					
HEATING									
0	32	30	64	109	18	75	76	80	0.62
0	32	55	117	199	31	72	73	77	0.52
0	32	80	170	289	67	68	71	74	0.46
-25	-13	30	64	109	29	65	66	82	0.65
-25	-13	52	110	187	49	60	62	79	0.53
COOLING									
35	95	30	64	107	18	TOTAL RECOVERY EFFICIENCY 65		ADJUSTED TOTAL RECOVERY EFFICIENCY 66	
35	95	70	148	253	55	55		56	

*Data not certified by HVI.

NOTE: All specifications are subject to change without notice.

SPECIFICATIONS

- Model: ERV250 ECM
- Part Number: ERV250TE
- Total Assembled Weight (including polymerized paper core): 96 lb. (44 kg)
- Oval shaped ports; fit 6" round ducts
- Drains: Optional
- Core Filters: 2 washable Merv 6 filters
- Housing: Pre-painted steel
- Optional HEPA Filter
- Insulation: Expanded polystyrene
- Mounting: Suspension by chains and springs or wall bracket system
- Supply and Exhaust Blower Motors:
 - Two ECM motors
 - Protection type: Thermally protected
- VT9W wall control offering 5 manual modes: Recirculation, 20 MIN/H, Continuous, Smart and Turbo. VT9W is sold separately.
- Energy Recovery Core:
 - Dimensions: 12" x 12" x 16.6" (30.5 cm x 30.5 cm x 42.2 cm)
 - Exchange surface: 168 ft.² (15.6 m²)
 - Weight: 14 lb. (6.4 kg)
 - Type: Cross flow
 - Material: Polymerized paper
 - Warranty: 10 years
- Unit Electrical Characteristics:

Volts	Frequency	Amps	Watts
120	60 Hz	2.2	135

Project:	REMARKS
Location:	
Part no.: ERV250TE	
Qty.:	
Submitted by: _____ Date: _____	



Broan-NuTone LLC, 926 West State Street, Hartford, Wisconsin, USA 53027 Broan-NuTone.com 800-558-1711



ERV250ECMd2111