



Nutone NTM Series NTM 系列

Meets your professional cooking needs. For the serious home chef!

- Very powerful 500 cfm twin motor hood.
- Halogen lighting (bulbs included).
- 3-speed control panel to match your cooking style.
- Smooth surfaces and the fully enclosed underside make cleaning easy.
- Three ducting options make installation easier 3 1/4 x 10 (horizontal – vertical) and 6" round (vertical) (adapters included).
- Grease pan and guard cups are quickly removed for cleaning.
- Grease capture design includes recess smoked grease pan underneath.
- Rounded edges compliments any modern decor.
- Electronic control with LED screen.
- Black control panel will blend in nicely with your decor.

滿足你專業的烹調需要。
對每家每戶的廚師都非常重要!

- 超強勁吸風力達每分鐘 500 立方尺之雙馬達抽油煙機
- 內附有 40 瓦照明裝置(內含燈泡)
- 3 速控制板適合你不同的烹飪風格。
- 光滑的表面及完整圍繞的底部結構便於清洗。
- 3 款不同排風口設計便於安裝 (橫置—垂直) 3 1/4" X 10" 及 (圓) 6" (垂直) (內含擋風片)。
- 易拆的集油板及滴油杯便於清洗。
- 集油裝置包括集油板和兩個滴油杯。
- 弧形的邊緣設計溶入了當代家居裝飾格調。
- 電子按鍵控制附LED屏幕
- 黑色控制面板易於協調您的廚房佈置

SPECIFICATIONS 特點

WIDTH 尺寸	STAINLESS STEEL 不銹鋼	WHITE 白色	VOLTS 電壓	CFM 最高風量	SONES 正常運作中之音量	DUCT 風出口
30"	NTM302SS	NTM302WH	120	500	4.1	3 1/4" x 10" (H.V) or 6" round 3-1/4" x 10" 置橫 -直垂或6"圓

OPTION

ARP6 Air flow reducer (limits the airflow of the hood under 300 CFM)
風量降低器 (限制風量低於每分鐘300立方尺).

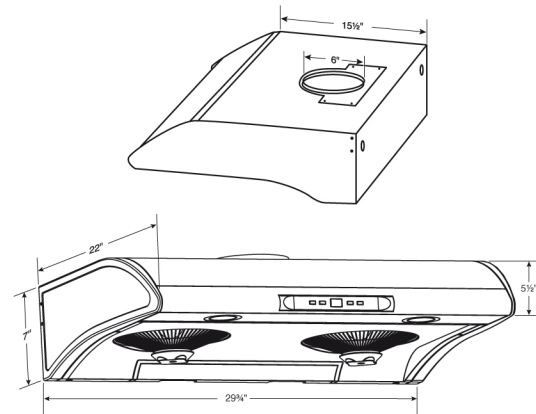

87448B 04/11

SPECIFICATIONS

MODEL	NTM SERIES
VOLTS	120 VAC
Hz	60
AMPS	2.0
CFM (HIGH SPEED)	500
CFM (LOW SPEED)	320
SONES (HIGH SPEED)	9.0
SONES (LOW SPEED)	4.5
DUCTING SIZE	6" ROUND OR 3¼" x 10"
2 SHIELDED HALOGEN BULBS	20 W, 12 V, JC TYPE, G4 BASE
WARRANTY	1 YEAR

DIMENSIONS

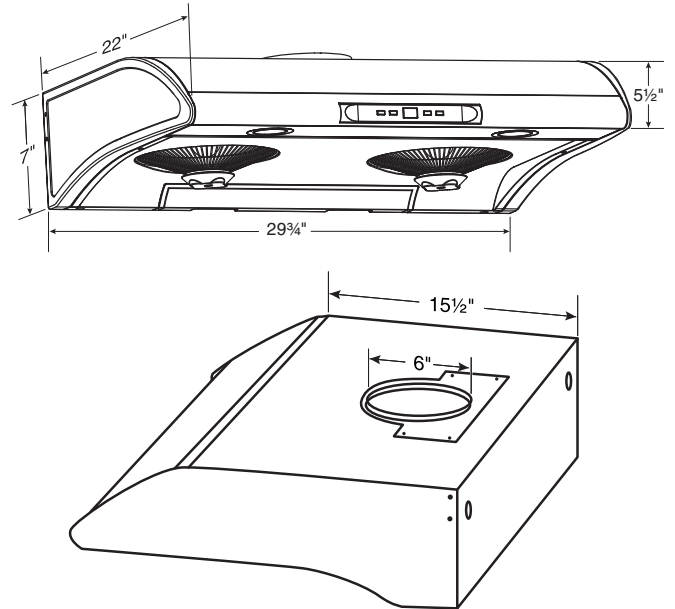

AIR FLOW PERFORMANCE

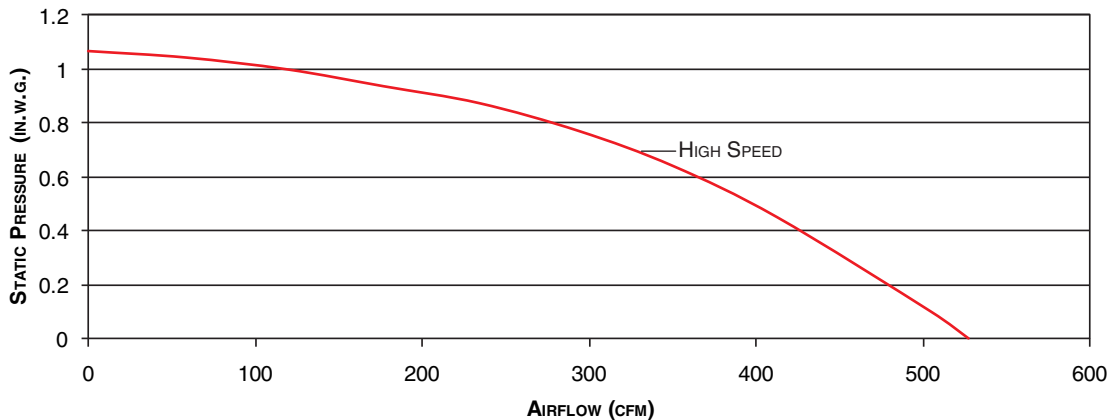

HVI-2100 CERTIFIED RATINGS comply with new testing technologies and procedures prescribed by the Home Ventilating Institute, for off-the-shelf products, as they are available to consumers. Product performance is rated at 0.1 in. static pressure, based on tests conducted in AMCA's state-of-the-art test laboratory. Sones are a measure of humanly-perceived loudness, based on laboratory measurements.



BROAN-NU-TONE CANADA INC., MISSISSAUGA, ONTARIO WWW.NUTONE.CA 1-888-882-7626

PROJECT	REMARKS
LOCATION	
MODEL No.	
QTY.	
SUBMITTED BY	
DATE	