

NIBCO® Press System Lead-Free Brass Ball Valves

Features: Press End Leak Detection • Two-Piece Body • PTFE Seats • Full Port • Blowout-Proof Stem

Approvals: IAPMO/ANSI Z1157 (IGC-157) • NSF/ANSI-61 & 372 • MSS SP-145 • Conforms to ASME B16.51†

Size range: 1/2" - 1"

Pressure rating: 250 PSI non-shock cold working pressure

Maximum pressure / temperature: 225 PSI at 250° F

Lead-free markings: White handle and blue hang tag

Applications: Drinking Water • Domestic Hot & Cold Water • HVAC (condensors, chilled water, hot water heating) • Isolation and Throttling (half-open to full-open only) • Connect to Rigid Copper Tubing Manufactured per ASTM B88, Condition H (hard drawn)

Reference Press System catalog for updated Approved Tool and Jaw Compatibility Matrix list.

Not intended for steam or gas usage.

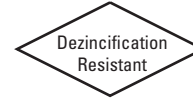

PCMT-FP-600A-LF

Press x MIP
1/2" - 1"

MATERIAL LIST

PART	SPECIFICATION
1. Body	Forged DZR Copper Alloy - C46500
2. Seat Seal	PTFE
3. O-ring	EPDM - ASTM D2000
4. Washer	PTFE
5. Lock Nut	Stainless Steel + Nylon
6. Handle	Steel, Plated
7. Stem	Brass
8. Ball	Chrome Plated Brass - C46500 (1/2"-1")
9. End Cap	Forged DZR Copper Alloy - C46500
10. O-ring	EPDM - ASTM D2000

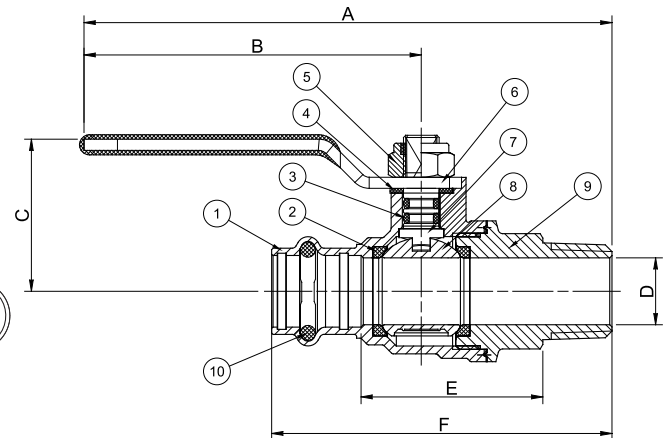

PCMT-FP-600A-LF
Press x Male
1/2" - 1"

Options:

- Extended lever
- EPDM Seal for Press Ends
- Wing Handle



Handle Markings

DIMENSIONS—WEIGHTS—QUANTITIES

SIZE		A		B		C		D		E		F		Weight	
In.	mm.	In.	mm.	In.	mm.	In.	mm.	In.	mm.	In.	mm.	In.	mm.	Lbs.	Kg.
1/2	12.7	5.30	134.70	3.62	92.00	1.34	34.00	0.59	15.00	1.60	40.70	3.00	76.20	0.4520	0.2050
3/4	19.05	6.07	154.20	4.13	105.00	2.06	52.20	0.79	20.00	2.00	50.70	3.53	89.70	0.7940	0.3601
1	25.40	6.29	159.70	4.13	105.00	2.21	56.20	0.98	25.00	2.23	56.70	3.89	98.70	1.1730	0.5320

IAPMO/ANSI Z1157: in addition to meeting ICG-157 test requirements, the IAPMO/ANSI Z1157 also requires Press ends to be fully tested to IAPMO PS-117 performance requirements which includes the following additional tests:

- | | |
|--|--|
| 1. Unrestrained Hydrostatic Pressure Test at 20 °C (68°F) | 6. Hydraulic Shock (Water Hammer) Test |
| 2. Unrestrained Hydrostatic Pressure Test at 93 °C (200°F) | 7. Vibration Test |
| 3. Static Torsion Test for Press Connections | 8. Thermal Cycling Test |
| 4. Bending Test | 9. Alternate Thermal Cycling Test |
| 5. Vacuum Test | 10. Dynamic Torsion Test for Press Connections |

†Tested to the performance criteria of ASME B16.51

WARNING: This product can expose you to chemicals including lead, which is known to the State of California to cause cancer and birth defects or other reproductive harm. For more information go to www.P65Warnings.ca.gov.

LEAD-FREE: Weighted average lead content ≤ 0.25%