

Lead-Free 250 PSI CWP Iron Body Grooved Silent Check Valves

Fire Protection • Twin Disc • Grooved Style • Bronze Disc • Nitrile • Spring Actuated

250 PSI/17.2 Bar Non-Shock Cold Working Pressure
Maximum Temperature to 180°F/82°C @ 220 PSI/15 Bar

CERTIFIED LEAD-FREE BY WQA TO NSF/ANSI 372
CONFORMS TO ANSI/AWWA C606 FOR STEEL IPS PIPE
• UL/ULC LISTED • FM APPROVED



C USA
COMPONENT
LEAD-FREE



KG-900-W-LF
Grooved

MATERIAL LIST

PART	SPECIFICATION
1. Body	Ductile Iron ASTM A536 Grade 65-45-12 w/Buna-N (Nitrile) resilient seat molded to body
2. Disc	Bronze ASTM B584 Alloy C87600
3. Torsion Spring	Stainless Steel UNS 31600 ASTM A313
4. Disc Hinge Pin	Stainless Steel UNS 31600 ASTM A276
5. Disc Stop Pin	Stainless Steel UNS 31600 ASTM A276
6. Disc Thrust Bearing	Stainless Steel UNS 31600 ASTM A240
7. Hinge Pin Retainer	Stainless Steel UNS 31600
8. Stop Pin Retainer	Stainless Steel UNS 31600
9. Stabilization Sphere	Buna-N
10. Spacer	Stainless Steel UNS 31600 ASTM A276

Sizes 10" and 12" furnished with lifting eyebolt

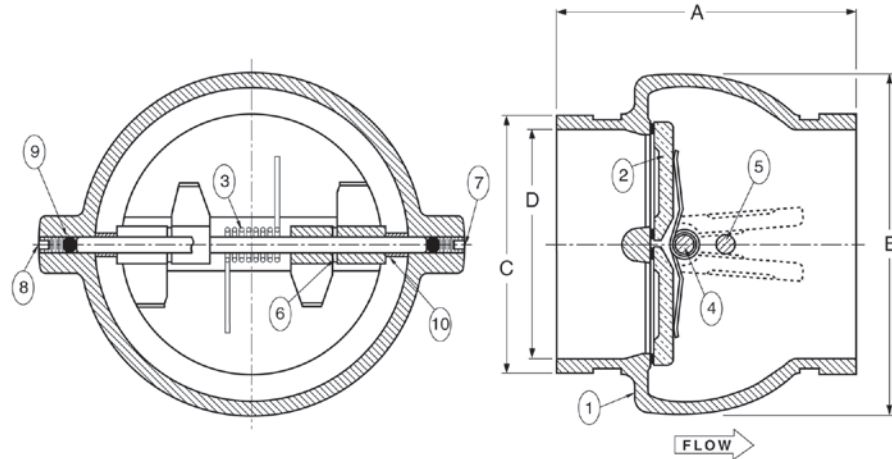

DIMENSIONS—WEIGHTS—QUANTITIES

Size	Dimensions								KG-900-W-LF	
	A		B		C		D		Lbs.	Kg.
In. mm.	In. mm.	In. mm.	In. mm.	In. mm.	In. mm.	In. mm.	In. mm.			
2½ 65	4.91 125	4.88 124	2.88 73	2.41 61	4.50 114	2.94 75	7.30 166	4.50	2.04	
3 80	5.31 135	5.38 137	3.50 89	2.94 75	7.30 166	4.50 114	7.30 166	7.30	3.31	
4 100	5.38 137	6.00 152	4.50 114	3.91 99	8.60 214	5.56 141	8.60 214	8.60	3.90	
5 125	5.72 145	7.06 179	5.56 141	4.89 124	13.00 315	5.92 150	13.00 315	13.00	5.90	
6 150	6.00 152	8.13 206	6.63 168	5.92 150	18.00 454	6.63 168	18.00 454	18.00	8.17	
8 200	6.72 171	10.03 255	8.63 219	7.91 201	30.00 762	8.63 219	30.00 762	30.00	13.6	
10 250	7.78 198	12.38 314	10.75 273	10.00 254	56.00 1417	10.75 273	56.00 1417	56.00	25.4	
12 300	8.19 208	14.38 365	12.75 324	11.94 303	81.80 2054	12.75 324	81.80 2054	81.80	36.7	

Groove dimensions conform to ANSI/AWWA specification C606 Table 4 (Cut Groove Dimensions)

*Lead Free refers to the wetted surface of pipe, fittings and fixtures in potable water systems that have a weighted average lead content ≤ 0.25% per the Safe Drinking Water Act (Sec. 1417) amended 1-4-2011 and other equivalent state regulations.

NOTE: Twin Disc Check Valves can be installed horizontally or in the vertical position with flow up.

CAUTION: For horizontal flow applications, the valve must be installed with disc hinge pin in the vertical position to insure proper operation.

WARNING:

1. These are not to be used as steam valves
2. Valves are not to be used near a reciprocating air compressor
3. Install 5 pipe diameters minimum downstream from pump discharge or elbows to avoid flow turbulence. Flow straighteners may be required in extreme cases.

NOTE: On pump discharge, the preferred check valves are in-line spring loaded.

WARNING: This product can expose you to chemicals including lead, which is known to the State of California to cause cancer and birth defects or other reproductive harm. For more information go to www.P65Warnings.ca.gov.

Visit our website for the most current information.

LEAD-FREE: Weighted average lead content <0.25%