



H-x685W Series

Forged DZR Brass Transition Tee

Certifications

Certified to NSF/ANSI 61 & 372, NSF/ANSI 14, IGC 319, PS117
Lead-Free

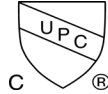

NO.	DESCRIPTION	MATERIAL
1	Body	Lead-Free DZR Brass
2	O-Ring	EPDM

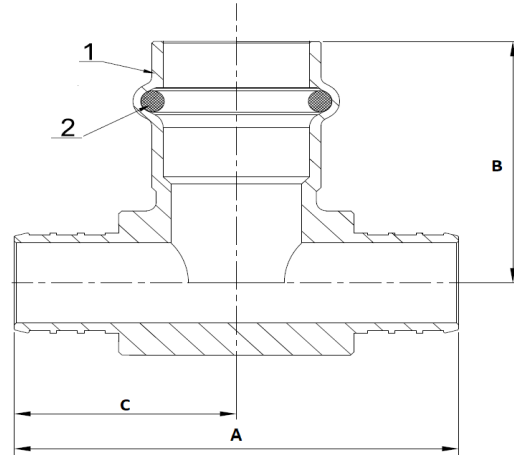

Designed for residential, commercial or industrial use with water, oil, or glycol mix. PEX end dimensions comply with the referenced ASTM specification.

ITEM#	Connection Type	SIZE (in)	Max Temp	Pressure Rating	A	B	C
H-16852W	F1807 PEX × F1807 PEX × Press	1/2	250°F Max	250 PSI CWP Max	2.40	1.38	1.20
H-16852W-BH	F1807 PEX × F1807 PEX × Press	1/2 × 1/2 × 3/4	250°F Max	250 PSI CWP Max	2.68	1.50	1.34
H-16853W	F1807 PEX × F1807 PEX × Press	3/4	250°F Max	250 PSI CWP Max	2.68	1.61	1.34
H-16853W-BH	F1807 PEX × F1807 PEX × Press	3/4 × 3/4 × 1	250°F Max	250 PSI CWP Max	2.91	1.89	1.46
H-16854W	F1807 PEX × F1807 PEX × Press	1	250°F Max	250 PSI CWP Max	3.27	2.01	1.63
H-16855W	F1807 PEX × F1807 PEX × Press	1 1/4	250°F Max	250 PSI CWP Max	3.80	2.26	1.90
H-36852W	F1960 PEX × F1960 PEX × Press	1/2	250°F Max	250 PSI CWP Max	2.56	1.38	1.28
H-36852W-BH	F1960 PEX × F1960 PEX × Press	1/2 × 1/2 × 3/4	250°F Max	250 PSI CWP Max	2.83	1.50	1.42
H-36853W	F1960 PEX × F1960 PEX × Press	3/4	250°F Max	250 PSI CWP Max	3.31	1.61	1.65
H-36853W-BH	F1960 PEX × F1960 PEX × Press	3/4 × 3/4 × 1	250°F Max	250 PSI CWP Max	3.54	1.89	1.77
H-36854W	F1960 PEX × F1960 PEX × Press	1	250°F Max	250 PSI CWP Max	4.02	2.01	2.01
H-36855W	F1960 PEX × F1960 PEX × Press	1 1/4	250°F Max	250 PSI CWP Max	4.80	2.26	2.40
H-36856W	F1960 PEX × F1960 PEX × Press	1 1/2	250°F Max	250 PSI CWP Max	5.47	2.36	2.74
H-36857W	F1960 PEX × F1960 PEX × Press	2	250°F Max	250 PSI CWP Max	7.05	3.11	3.52