



PATENTS PENDING

## H-x112W Series

Pro-Pal Dielectric Union Ball  
 Full Port Forged DZR Brass Ball Valve  
 w/ Galvanized Steel Union End,  
 Nylon Insulator Ring,  
 Reversible Handle  
 & Dual Stem Seal Design

### Certifications

Certified to NSF/ANSI 61 & 372  
 Lead-Free



NO.	DESCRIPTION	MATERIAL
1	O-ring	EPDM
2	Body	Lead-Free DZR Brass
3	Seat	PTFE
4	O-ring	EPDM
5	Packing	PTFE
6	Packing Gland	Brass
7	Handle	Steel CP
8	Handle Nut	Steel
9	Lock Washer	Steel
10	Stem	Brass
11	Ball	Brass HCP
12	Cap	Lead-Free DZR Brass
13	Union Nut	Galvanized Steel
14	Gasket	EPDM
15	Insulator Ring	Nylon
16	FIP Fitting	Galvanized Steel

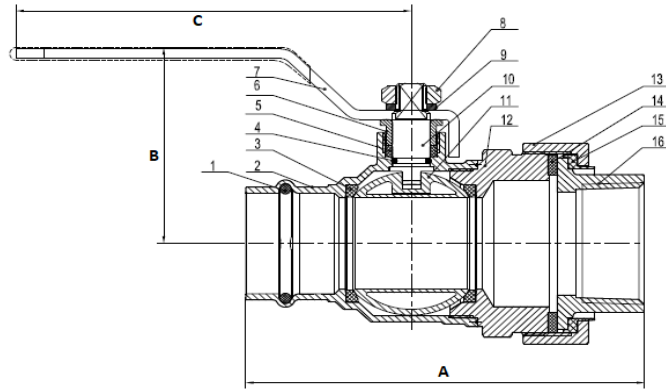

Designed for residential, commercial, or industrial use with water, oil, or glycol mix. This approved Webstone valve is actuated by a blowout proof stem and features an adjustable packing gland. Threaded ends comply with ANSI B1.20.1.

ITEM#	Connection Type	SIZE (In)	Max Temp	Pressure Rating	A	B	C
H-81122W	FIP Union x Press	1/2"	200 °F Max	250 PSI CWP Max	3.74	2.13	3.75
H-81123W	FIP Union x Press	3/4"	200 °F Max	250 PSI CWP Max	4.09	2.13	4.00
H-81124W	FIP Union x Press	1"	200 °F Max	250 PSI CWP Max	4.49	2.50	4.50
H-81125W	FIP Union x Press	1 1/4"	200 °F Max	250 PSI CWP Max	5.04	2.75	5.13
H-81126W	FIP Union x Press	1 1/2"	200 °F Max	250 PSI CWP Max	5.75	3.15	6.18
H-81127W	FIP Union x Press	2"	200 °F Max	250 PSI CWP Max	6.73	3.63	6.18