

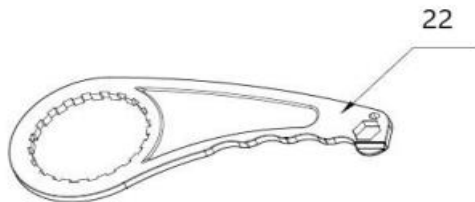

H-7x70XL Series

Magnetic Boiler Filter XL
 12,000 Gauss Magnet
 Integrated Hose Drain Valve, Air Vent & Filter
 Includes (2) Union End Connections & Service Tool

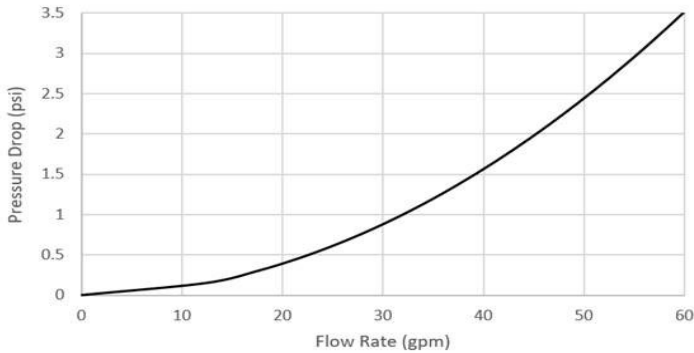

PATENTS PENDING

NO.	DESCRIPTION	MATERIAL
1	Magnet Bar	Various
2	O-ring	Rubber
3	Magnet Sleeve	Nickel Plated Brass
4	Body Upper Half	Brass
5	Outer Screen	Stainless Steel
6	Inner Screen	Stainless Steel
7	Body Lower Half	Plastic
8	Valve Cap	Brass
9	O-Ring	Rubber
10	O-Ring	Rubber
11	Valve Stem	Brass
12	O-Ring	Rubber
13	Strap	Rubber
14	Hose Cap	Brass
15	Gasket	Rubber
16	Valve Body	Brass
17	Valve Seat	Teflon
18	Valve Ball	Brass HCP
19	Vent Assembly	Various
20	Screen Guide	Plastic
21	O-Ring	Rubber
22	Service Tool	Plastic
23	O-Ring	Rubber

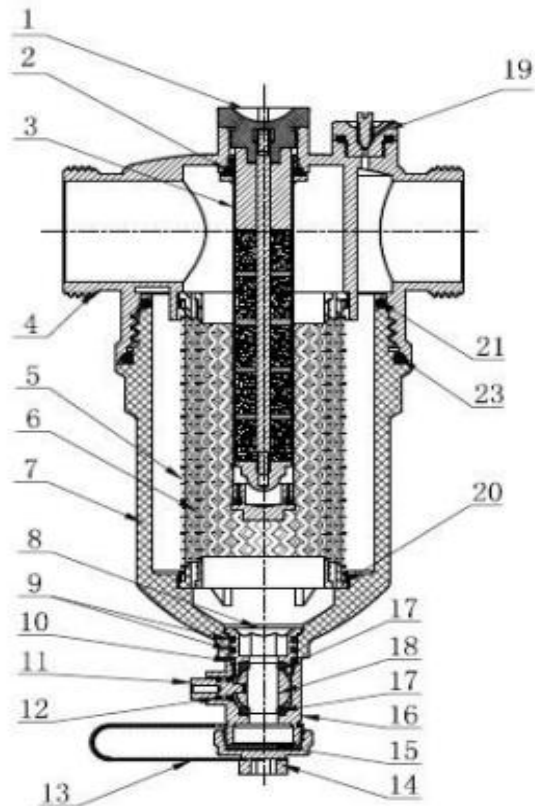

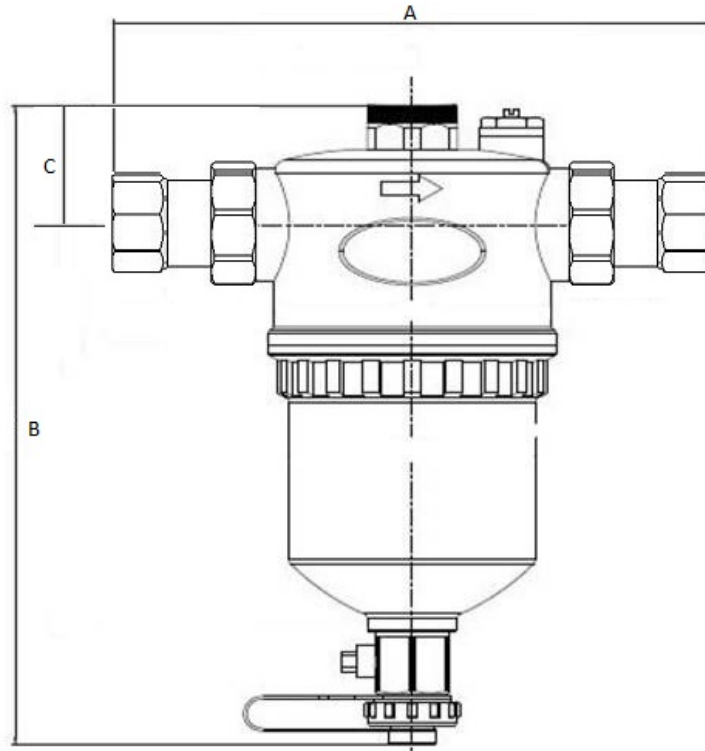

Designed for residential, commercial, or industrial use with water or a glycol mixture. Ensure 5.5" of clearance above the unit so that the magnetic bar may be removed for service. *EPDM o-ring for press ends.

ITEM#	Connection Type	SIZE (In)	Max Temp	Pressure Rating	A	B	C
H-72705	MIP	1 1/4	250°F Max	145 PSI CWP Max	9.20	9.37	1.75
H-72706	MIP	1 1/2	250°F Max	145 PSI CWP Max	9.30	9.37	1.75
H-74705	FIP	1 1/4	250°F Max	145 PSI CWP Max	8.80	9.37	1.75
H-74706	FIP	1 1/2	250°F Max	145 PSI CWP Max	8.90	9.37	1.75
H-75705	SWT	1 1/4	250°F Max	145 PSI CWP Max	7.50	9.37	1.75
H-75706	SWT	1 1/2	250°F Max	145 PSI CWP Max	9.50	9.37	1.75
* H-78705	Press	1 1/4	250°F Max	145 PSI CWP Max	10.00	9.37	1.75
* H-78706	Press	1 1/2	250°F Max	145 PSI CWP Max	11.10	9.37	1.75



H-7x70XLB Series

Magnetic Boiler Filter XL Body
 12,000 Gauss Magnet
 Integrated Hose Drain Valve, Air Vent & Filter
 & Service Tool
 Requires (2) G-Union Fittings (Sold Separately)

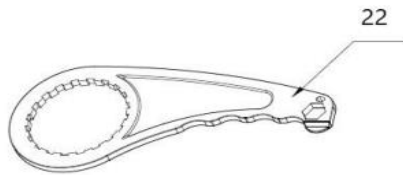
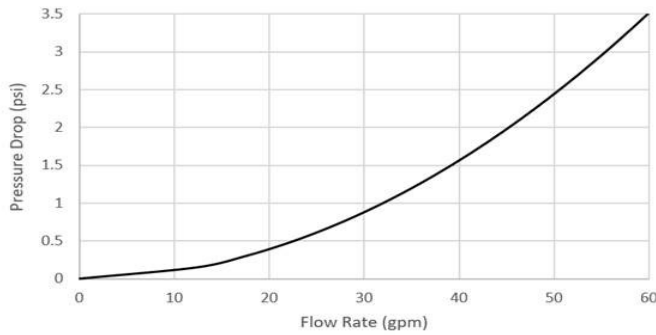
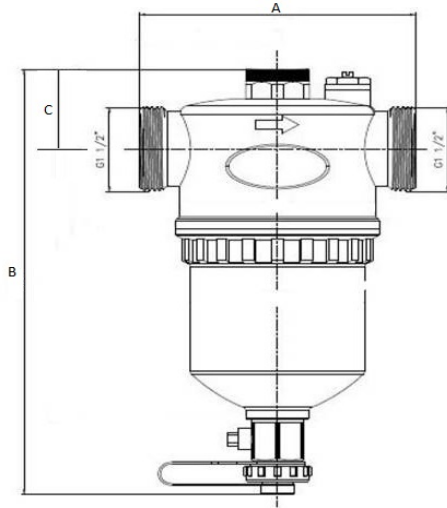

PATENTS PENDING		
NO.	DESCRIPTION	MATERIAL
1	Magnet Bar	Various
2	O-ring	Rubber
3	Magnet Sleeve	Nickel Plated Brass
4	Body Upper Half	Brass
5	Outer Screen	Stainless Steel
6	Inner Screen	Stainless Steel
7	Body Lower Half	Plastic
8	Valve Cap	Brass
9	O-Ring	Rubber
10	O-Ring	Rubber
11	Valve Stem	Brass
12	O-Ring	Rubber
13	Strap	Rubber
14	Hose Cap	Brass
15	Gasket	Rubber
16	Valve Body	Brass
17	Valve Seat	Teflon
18	Valve Ball	Brass HCP
19	Vent Assembly	Various
20	Screen Guide	Plastic
21	O-Ring	Rubber
22	Service Tool	Plastic
23	O-Ring	Rubber

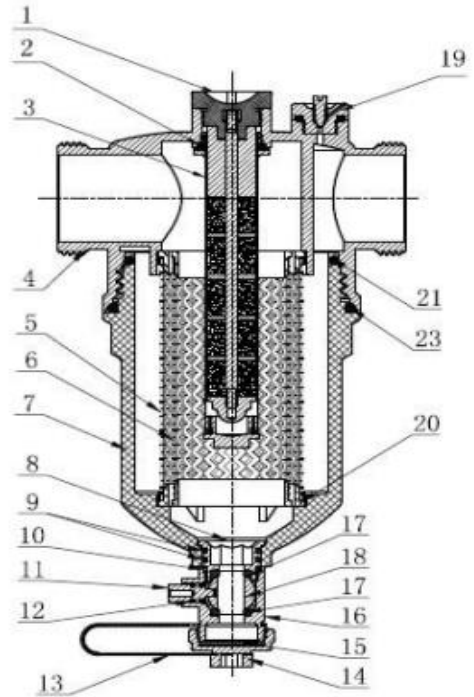

Designed for residential, commercial, or industrial use with water or a glycol mixture. Ensure 5.5" of clearance above the unit so that the magnetic bar may be removed for service.

ITEM#	Connection Type	SIZE (in)	Max Temp	Pressure Rating	A	B	C
H-70706	G-Thread	1 1/2	250°F Max	145 PSI CWP Max	5.12	9.37	1.75