

## 300 PSI CWP Iron Body Gate Valves

Fire Protection Post Indicator Valve • Bolted Bonnet • Indicator Post Pattern •  
Non-Rising Stem • Resilient Wedge • Epoxy Coated Interior/Exterior



NSF/ANSI 61  
NSF/ANSI 372

**300 PSI/20.6 Bar Non-Shock Cold Working Pressure**  
**(160° F/71° C max. operating temperature)**

UL/ULC LISTED • FM APPROVED •  
CERTIFIED LEAD-FREE\* TO NSF/ANSI 372



**FM609-RWS**  
Flanged x Mechanical Joint

### MATERIAL LIST

PART	SPECIFICATION
1 Valve Body	Ductile Iron ASTM A536
2 Resilient Wedge	Ductile Iron ASTM A536 / EPDM ASTM D2000
3 Wedge Nut	ASTM B584 UNS C83600
4 Stem	Stainless Steel 304
5 Bonnet Gasket	EPDM ASTM D2000
6 Bonnet Screw	Corrosion-resistant Steel
7 Bonnet	Ductile Iron ASTM A536
8 Stem Primary O-Ring	EPDM ASTM D2000
9 Stem Thrust Washer (lower)	Bronze ASTM B584 UNS C83600
10 Stem Thrust Washer (upper)	Stainless Steel ASTM A276 UNS S41000
11 Gland Seal O-Ring	EPDM ASTM D2000
12 Stem Seal Bushing	ASTM B584 UNS C83600
13 Stem Secondary O-Ring	EPDM ASTM D2000
14 Gland Flange	Ductile Iron ASTM A536
15 Stem Ring Wiper	EPDM ASTM D2000
16 Square Operating Nut	Cast Iron ASTM A126-B
17 Operating Nut Washer	ASTM A276 SS304
18 Operating Nut Screw	Alloy Steel ASTM A574M Zinc Plated
19 Gland Flange Screw	Alloy Steel ASTM A574M Zinc Plated
20 Indicator Flange Screw	Alloy Steel ASTM A574M Zinc Plated
21 Indicator Post Flange	Cast Iron ASTM A126-B
22 UL/FM Label (not shown)	Aluminum
23 Drive Screw, Label (not shown)	Stainless Steel 304

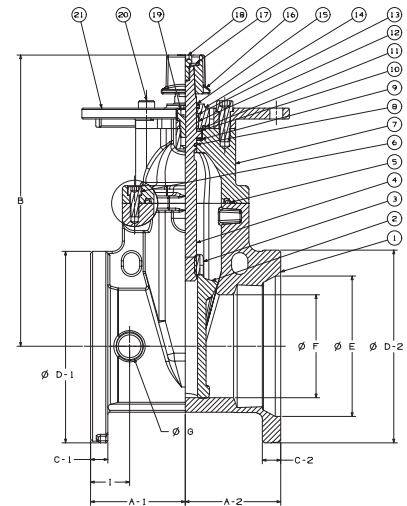

**FM609-RWS**  
Flg x MJ

Coating — Electrostatically applied fusion-bonded epoxy 8-20 mil. inside and outside meets or exceeds AWWA C550.

NOTE: Flanged valve is consistent with ANSI B16.1 Class 125.

### DIMENSIONS—WEIGHTS—QUANTITIES

Size	Dimensions																
	A-1		A-2		B		C-1		C-2		D-1		D-2		E		F
In. mm.	In. mm.	In. mm.	In. mm.	In. mm.	In. mm.	In. mm.	In. mm.	In. mm.	In. mm.	In. mm.	In. mm.	In. mm.	In. mm.	In. mm.	In. mm.	In. mm.	In. mm.
4	100	4.75 115	4.75 127	13.50 344	0.94 24	1.00 26	9.00 229	9.10 232	6.00 153	3.90 100							
6	150	5.50 134	5.50 146	17.00 441	1.00 25	1.06 27	11.00 279	11.10 283	8.10 206	5.90 150							
8	200	5.75 146	5.75 146	20.75 529	1.13 29	1.12 28	13.50 343	13.40 340	10.30 261	7.90 200							
10	250	6.50 165	6.50 165	24.00 614	1.19 30	1.18 30	16.00 406	15.60 397	12.30 313	9.80 250							
12	300	7.00 178	7.00 179	27.00 700	1.25 32	1.25 32	19.00 486	17.90 454	14.40 367	11.80 300							

Size	G		I		Flanged B.C.		MJ B.C.		No. Holes		Turns		Weight	
In. mm.	In. mm.	In. mm.	In. mm.	In. mm.	In. mm.	In. mm.	In. mm.	Flanged	M-Joint	To Open	Lbs.	Kg.		
4	100	1.42 54	2.13 54	7.50 191	7.50 191	8	4	12.5	72	33				
6	150	1.54 64	2.24 57	9.50 241	9.50 241	8	6	15.0	103	47				
8	200	1.54 70	2.48 63	11.75 296	11.75 298	8	6	16.7	99	45				
10	250	1.82 70	3.15 65	14.25 362	14.00 356	12	8	20.8	247	112				
12	300	1.82 86	2.91 74	17.01 432	16.25 413	12	8	25.0	377	171				

**FREEZING WEATHER PRECAUTION:**  
Subsequent to testing a piping system, gate valve should be in an open position to allow complete drainage.

**WARNING:** This product can expose you to chemicals including lead, which is known to the State of California to cause cancer and birth defects or other reproductive harm. For more information go to [www.P65Warnings.ca.gov](http://www.P65Warnings.ca.gov).

\*Weighted average lead content ≤ 0.25%

Visit our website for the most current information.