

# Class 150 Ductile Iron Body Gate Valves

Raised Face Flanges • Bolted Bonnet • Outside Screw and Yoke • Solid Wedge • 316 Stainless Steel Trim

**285 PSI/19.7 bar non-shock working pressure to -20°F to 100°F/-29°F to 38°C\***

**Maximum working temperature 450°F/343°C at 125 PSI/8.6 bar**

**150 PSI/10.3 bar saturated steam to 366°F/186°C**



NSF/ANSI 61  
NSF/ANSI 372

CERTIFIED LEAD-FREE\* TO NSF/ANSI-61-8 (INCLUDES ANNEX F AND G) AND NSF/ANSI-372 • CONFORMS TO MSS SP-128

## MATERIAL LIST

PART	SPECIFICATION
1. Stem	Stainless Steel ASTM A 276 S31600
2. Handwheel Nut	Ductile Iron ASTM A395
3. Identification Plate	Aluminum
4. Yoke Bushing	Ductile Iron ASTM A536
5. Handwheel	Iron ASTM A126 Class B
6. Bonnet Cap Nut	Steel ASTM A563
7. Bonnet Cap	Ductile Iron ASTM A536
8. Bonnet <sup>1</sup>	Ductile Iron ASTM A395
9. Bonnet Cap Bolt	Steel ASTM A307/SAE J429
10. Gland Follower Nut	Steel ASTM A563
11. Gland Follower	Ductile Iron ASTM A536
12. Packing Gland	Stainless Steel ASTM A276 S31600
13. Packing	PTFE Braided Synthetic Fiber
14. Gland Follower Bolt	Steel ASTM A307/SAE J429
15. Backseat Bushing	Stainless Steel ASTM A276
16. Body Nut	Steel ASTM A563
17. Body Bolt	Steel ASTM A307/SAE J429
18. Wedge Pin	Stainless Steel ASTM A276
19. Body	Ductile Iron ASTM A 395
20. Seat Ring <sup>2</sup>	Stainless Steel ASTM A 351 CF8M
21. Wedge Face Ring	Stainless Steel ASTM A 351 CF8M
22. Wedge <sup>2</sup>	Ductile Iron ASTM A 395
23. Body Gasket	Synthetic Fibers
24. Stem Collar	Stainless Steel ASTM A276 S31600
25. Grease Fitting	Alemite 1743B (not shown)

<sup>1</sup> Sizes 2" thru 8" made with Yoke Integral with Bonnet. 10" and 12" sizes made with separate Yoke Bolted to Bonnet.

<sup>2</sup> Size 2" thru 3" have solid wedges ASTM A351 CF8M. Sizes 4" thru 12" made with ASTM A395 wedge with ASTM A351 CF8M face rings.

## DIMENSIONS—WEIGHTS—QUANTITIES

Size	Dimensions										Weight		
	A		B		C		D		E		Lbs.	Kg.	
In. mm.	In.	mm.	In.	mm.	In.	mm.	In.	mm.	In.	mm.			
2	50	7.00	178	16.31	414	8.00	203	6.00	152	.63	16	40	18
2½	65	7.50	191	17.19	437	8.00	203	7.00	178	.69	17	54	25
3	80	8.00	203	19.50	495	8.00	203	7.50	191	.75	19	66	30
4	100	9.00	229	24.00	610	10.00	254	9.00	229	.94	24	107	48
5	125	10.00	254	27.13	689	10.00	254	10.00	254	.94	24	144	66
6	150	10.50	267	31.06	789	12.00	305	11.00	279	1.00	25	178	81
8	200	11.50	292	40.19	1021	14.00	356	13.50	343	1.13	29	309	140
10	250	13.00	330	48.25	1226	16.00	406	16.00	406	1.19	30	479	217
12	300	14.00	356	56.88	1445	18.00	457	19.00	483	1.25	32	706	320

\*Weighted average lead content ≤ 0.25%

Visit [www.nibco.com](http://www.nibco.com) for current Chem-Guide and galvanic potential in piping systems information.

NIBCO INC. WORLD HEADQUARTERS • 1516 MIDDLEBURY ST. • ELKHART, IN 46516-4740 • USA • PH: 1.800.234.0227  
TECH SERVICES PH: 1.888.446.4226 • FAX: 1.888.336.4226 • INTERNATIONAL OFFICE PH: +1.574.295.3327 • FAX: +1.574.295.3455  
www.nibco.com

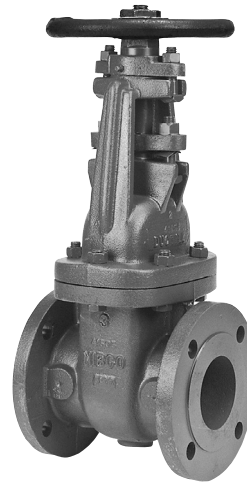

**F-637-33**  
Flanged-Raised Face

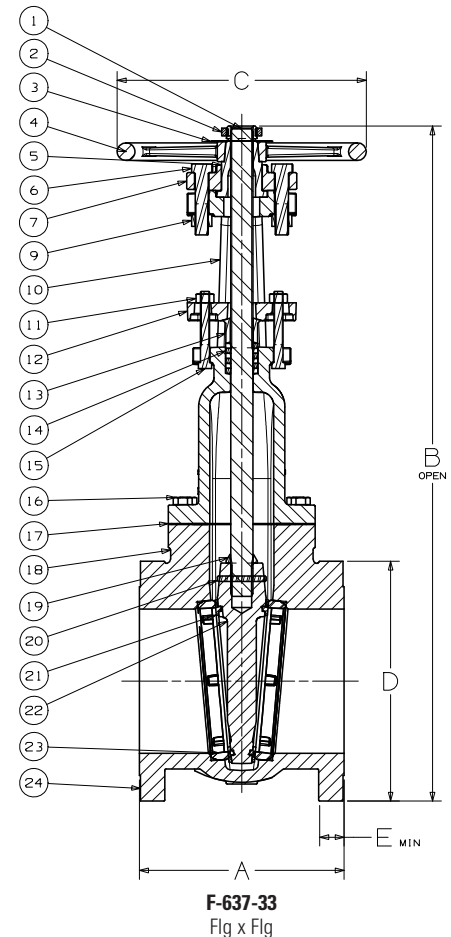

**WARNING:** This product can expose you to chemicals including lead, which is known to the State of California to cause cancer and birth defects or other reproductive harm. For more information go to [www.P65Warnings.ca.gov](http://www.P65Warnings.ca.gov).