

drill reference holes (prefer one on top, one on side for Side Panels, 2 on top for Center Panel) into the studs/bracing with the appropriate drill bit for the "deck" screws; drill 1/8" dia. holes - max. THESE HOLES WILL ALIGN UNIT WHEN YOU ARE READY FOR THE PERMANENT INSTALL.

- ★ With panels temporarily in place, lightly trace along bottom edge of panels onto bathtub with a pencil. Remove panels and apply a 1/4" bead of silicone sealant all around where panels contact bathtub (locate approx. 1/4" back from pencil line) see Fig. G.

Hold Center Panel approx. 2" above bathtub flange and in contact with stud faces. Slide panel down into bead of silicone sealant so that mounting clips lock behind bathtub flange (Fig.F).

- ★ Shim panel as required and secure to studs/bracing with "deck" screws through previously drilled mounting holes. Apply a bead of sealant to one of the vertical grooves on the Center Panel (Fig. C).

Each Side Panel has a blade (running the full height of the panel) that engages into the corresponding Center Panel groove. Hold Side Panel approximately 1/2" above Center Panel.

- ★ Align and insert blade into groove and lower Side Panel into place. Top edges should be level (Fig. C). Wipe away any excess silicone sealant that may have seeped out onto the finished surface. Shim panels (level and plumb) as needed and secure to studs/bracing with "deck" screws through previously drilled holes.

- ★ Apply silicone sealant to remaining Center Panel groove as in previous step and repeat procedure for remaining Side Panel. (OPTIONAL)

Finish alcove with W/R rated wallboard. Wallboard should cover mounting flanges.  
NOTE: Wallboard can either be "back-cut" or stud faces "furred" out (1/8" - 1/4" hardboard or plywood) to accommodate thickness of mounting flange.

- ★ Seal all around on panel seams and where panels meet bathtub and wallboard with a quality tub/tile sealant.

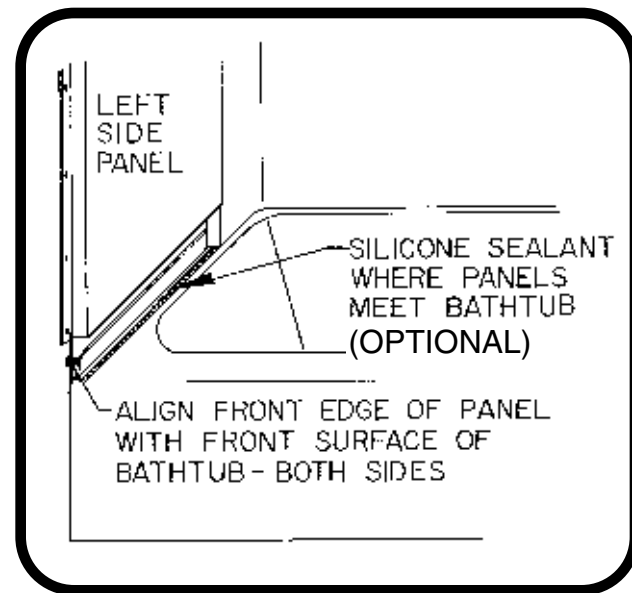

Fig. G

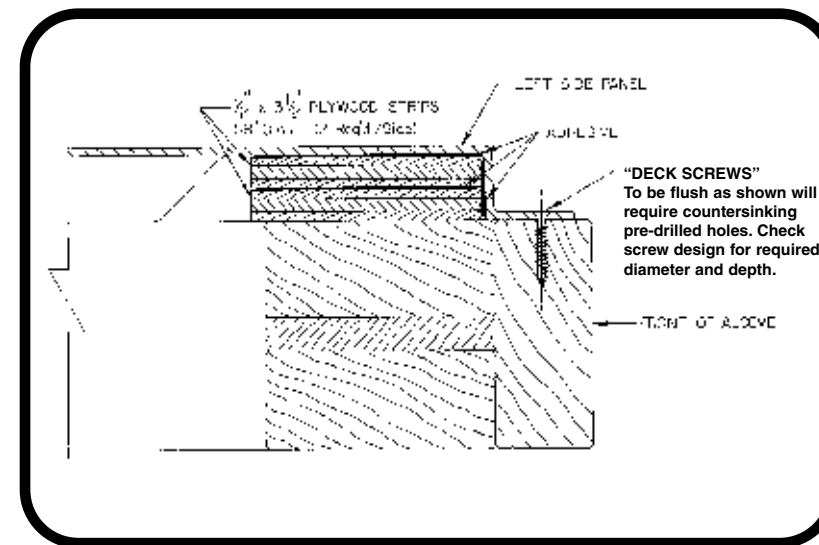

Fig. H

# MUSTEE FIBERGLASS BATHTUB WALL

## MODEL 660

### TOOLS

Drill Bits (5/32" & 1/8")  
Electric or Hand Drill  
Caulking Gun  
Tape Measure  
Level (24" minimum)  
Screwdrivers (standard & Phillips)  
Hole Saw - (Faucet & Spray Head Holes)  
Hammer  
Square  
Nails  
Countersink Bit\*

### MATERIALS

Silicone Sealant - Clear  
Tub Surround Adhesive  
Deck Screws  
2 x 4 Framing Lumber as Required  
Wall Board (W/R Rated) as required  
Fiberglass Insulation\*  
1 x 4 x 52" Board  
1/2" CDX Plywood Strips as Required  
Shims

### CARE & CLEANING

The surface of your Mustee Fiberglass Bathtub Wall may be cleaned with a mild soap solution in warm water using a soft cloth. When using a cleaner product, carefully read the label to ensure that the cleaner is safe for the use on the material. Stubborn stains may be cleaned using "Soft-Scrub®" by CloroX®, "Tub & Tile Cleaner"® by Lysol® or a powdered detergent such as "Spic-n-Span". Do not allow cleaners to sit and soak on the surface. Wipe surface clean and rinse completely with water immediately after cleaner application. Rinse and dry overspray on nearby surfaces. Never use abrasive scouring powder or steel wool pads, as they will dull and scratch the surface.

### ACCESSORIES

Soap Shelf - 12" wide soap dish provides ample storage for all sizes of soap, shampoo and other shower accessories. Adhesive mount design allows for easy installation and unlimited placement opportunities.

Part No.	Color
572.300	White
572.300BN	Bone

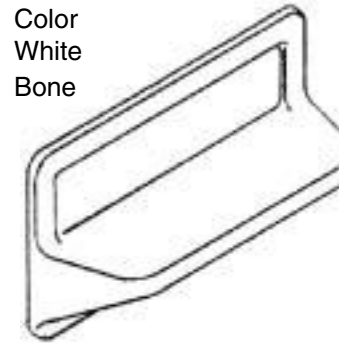

Quality Plumbing Products  
**E.L. MUSTEE & SONS, INC.**  
5431 West 164th Street • Brook Park, Ohio 44142

# MUSTEE FIBERGLASS BATHTUB WALL

## INSTALLATION INSTRUCTIONS

### MODEL 660

DIRECT MOUNTING TO STUDWALLS

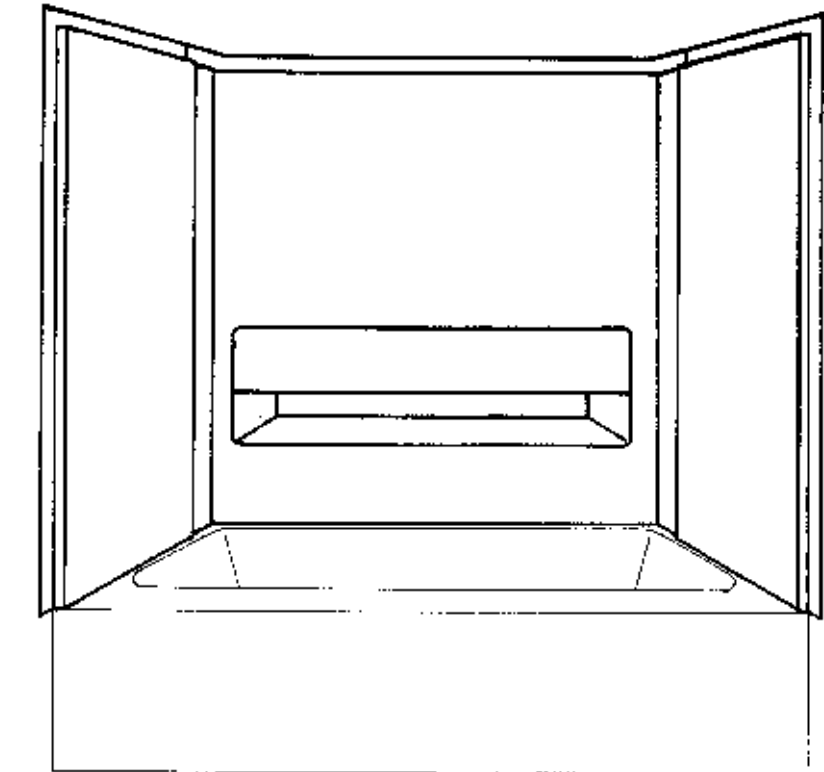

FITS MOST 30" X 60" BATHTUBS

### IMPORTANT:

Before you assemble and install your MODEL 660 three-piece Molded Fiberglass Bathtub Wall Unit, you will have to prepare the rough-in area, determine which side wall will have the shower head & control valve and if unit will be equipped with a bathtub door or curtain. Please read instructions before proceeding with installation. The bathtub wall unit does not require any trimming or cutting for normal installations.



Quality Plumbing Products  
**E.L. MUSTEE & SONS, INC.**  
5431 West 164th Street • Brook Park, Ohio 44142

**TOOLS AND MATERIALS\*** See back cover page

**ROUGH-IN FRAMING**

Refer to Fig. A & B for recommended alcove framing. If framing is pre-existing and you choose not to re-frame, you **MUST** make sure existing stud placement will not interfere with mounting clips. Be sure to plan your rough plumbing requirements (drain-venting-supply lines) at this time.

**HINT:** You may want to install Kraft Faced fiberglass insulation or unfaced batting with a 4 mil. (poly) vapor barrier film between the open studs of your alcove area.

After you have prepared your alcove and completed your rough plumbing requirements, proceed with installation of bathtub (if applicable) per tub manufacturer's instructions.

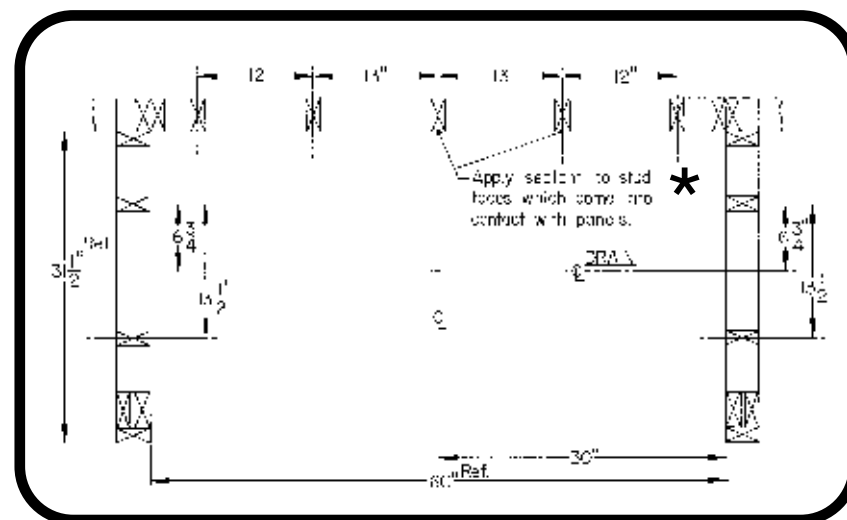

**Fig. A**

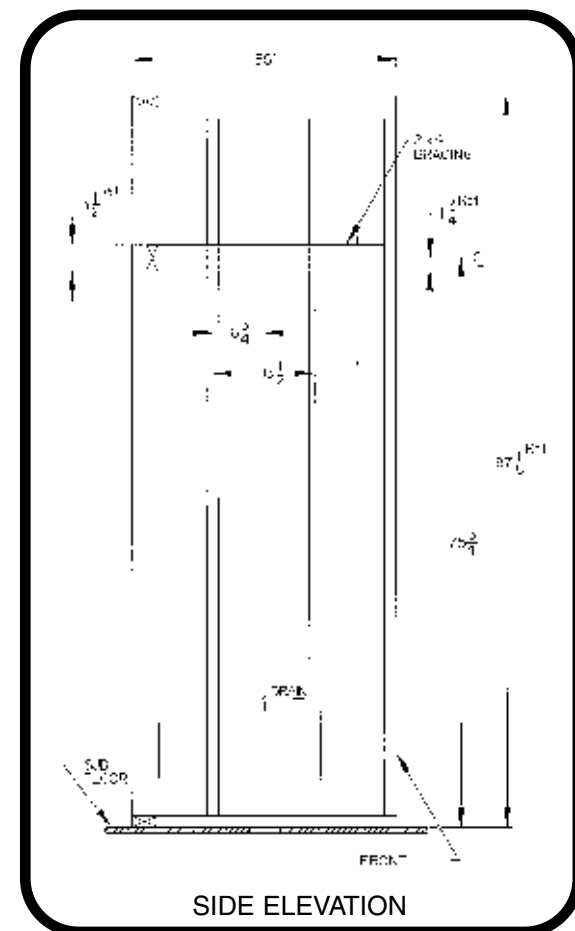

**Fig. B**

Please review the following steps (A thru E) before beginning the permanent Model 660 Bathtub Wall installation.

A. One of the Side Panels will require drilling for the mixing/control valve handle(s), tub spout & showerhead (if applicable). The showerhead may be located through the Side Panel or above it (whichever you chose in your rough plumbing). Double check all measurements before you do any drilling. The drilling should be completed before the unit is installed. Drill from the finished (inside) surface. **IMPORTANT:** Be sure to take into account the Center Panel wrap around when laying out hole locations (see Fig. D).

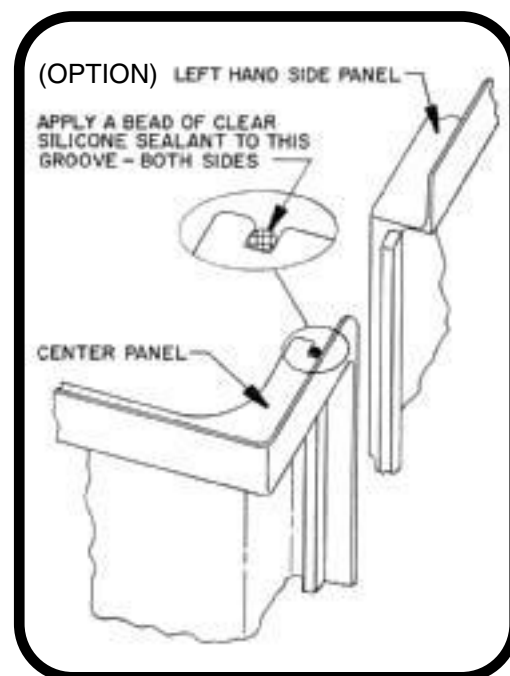

**Fig. C**

B. The Center and Side Panels have a mounting flange that is designed to accept standard “drywall” screws. The positioning of the studs and bracing (see ROUGH-IN FRAMING) have been laid out to give maximum support (horizontally and vertically) behind these flanges. The mounting flanges have pre-marked holes - to avoid cracking the flange, it is recommended that you pre-drill all of the holes with a 5/32” (inch) diameter drill bit. Countersink holes for flush screw head fit, Fig. H.

C. **To avoid any creaking or bowing that may take place with normal settling of the structure, every pre-marked hole should be utilized.**

D. If a bathtub door (enclosure) is to be installed with this unit, we recommend bonding plywood strips to the backside of each Side Panel prior to installation of the unit. If a curtain is to be used, the same plywood strips should be used to “back-up” the mounting brackets (Fig. H). If unit has been installed and no reinforcing strips have been used and you decide to mount either a shower door or curtain - You **MUST** use “Molly”-type clinching anchors for all screws. See drawing, Fig. D.



E. If installing ADA grab bars, you **MUST** reinforce panels by bonding strips of wood/plywood to back side of panels as shown in Fig. D.

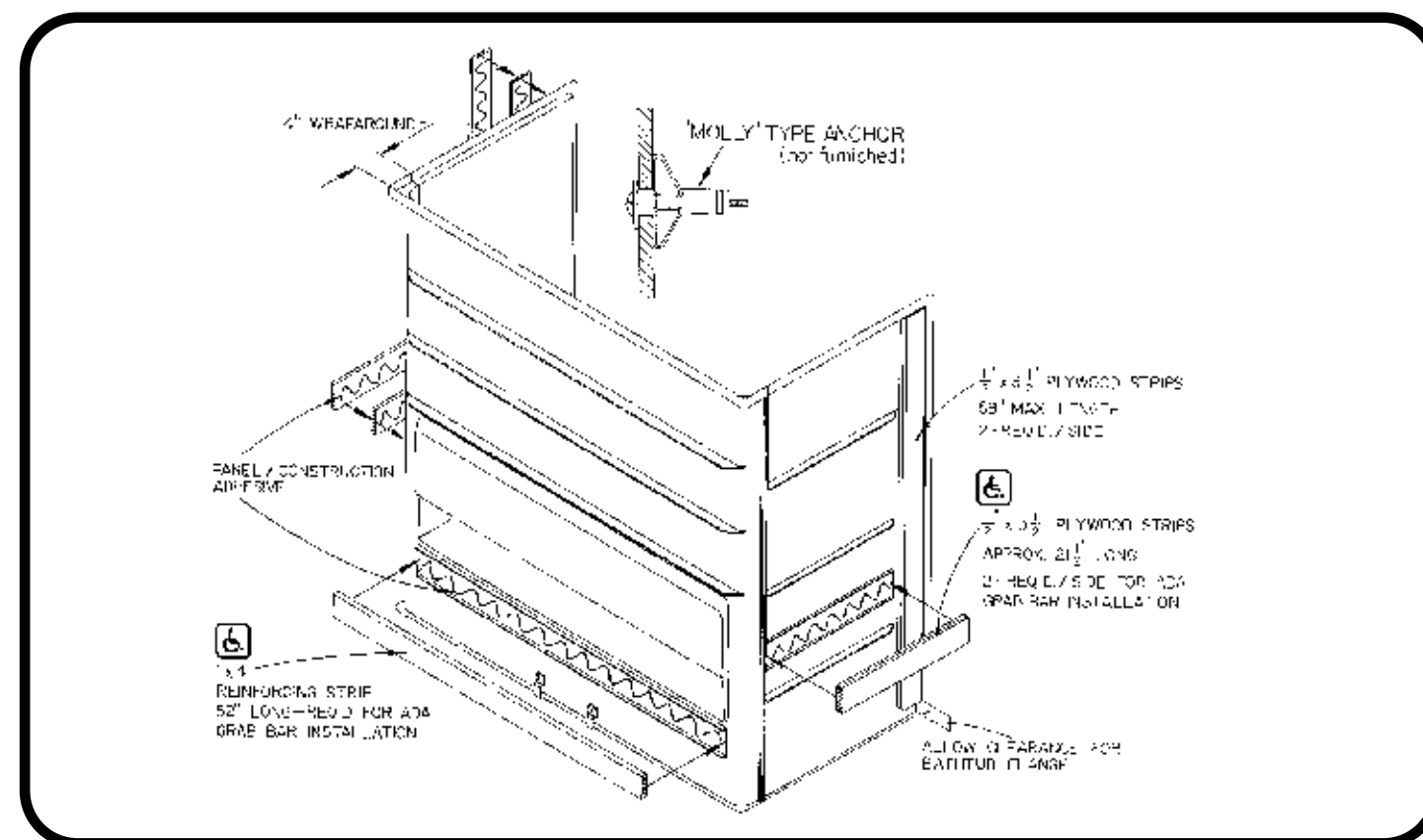

**Fig. D**

1. ATTACH MOUNTING CLIPS...
  - a) Position clips on molded lugs located near bottom of Center Panel with clips pointing “down” as shown in drawing (Fig. E).
  - b) Secure the clips using the two (2) #12 x 5/8” screws provided.

**CAUTION:** Do not over-tighten screws! Use a standard #2 Phillips screwdriver.

2. Attach REINFORCING STRIPS\* (optional for standard installation)
  - a) Bond a piece of 1 x 4 to backside of Center Panel as shown to reinforce ADA Grab Bar (Fig. D).

\*NOTE: Grab Bars must be secured THROUGH REINFORCING STRIPS and into stud or wall plate!

**SIDE PANEL PREPARATION**

1. Attach door/curtain rod REINFORCING STRIPS
  - a) Bond 1/2” thick plywood strips to backside of both Side Panels to reinforce door/curtain rod. Be sure to allow clearance at bottom of panels for bathtub flange (Fig. D & Fig. H).
2. Attach REINFORCING STRIPS\* (optional for standard installation)
  - a) Bond 1/2” thick plywood strips to backside of Side Panels as shown to reinforce ADA Grab Bars (Fig. D).

\*NOTE: Grab Bars must be secured THROUGH REINFORCING STRIPS and into stud or wall plate!

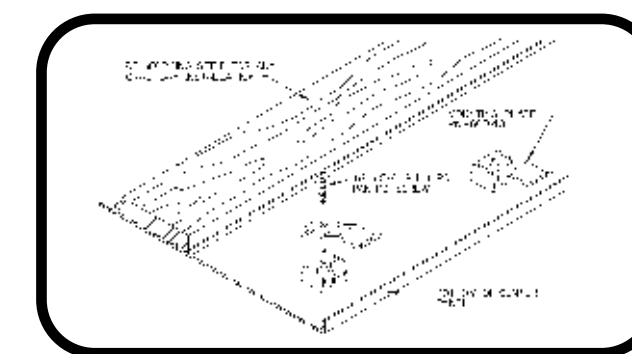

**Fig. E**

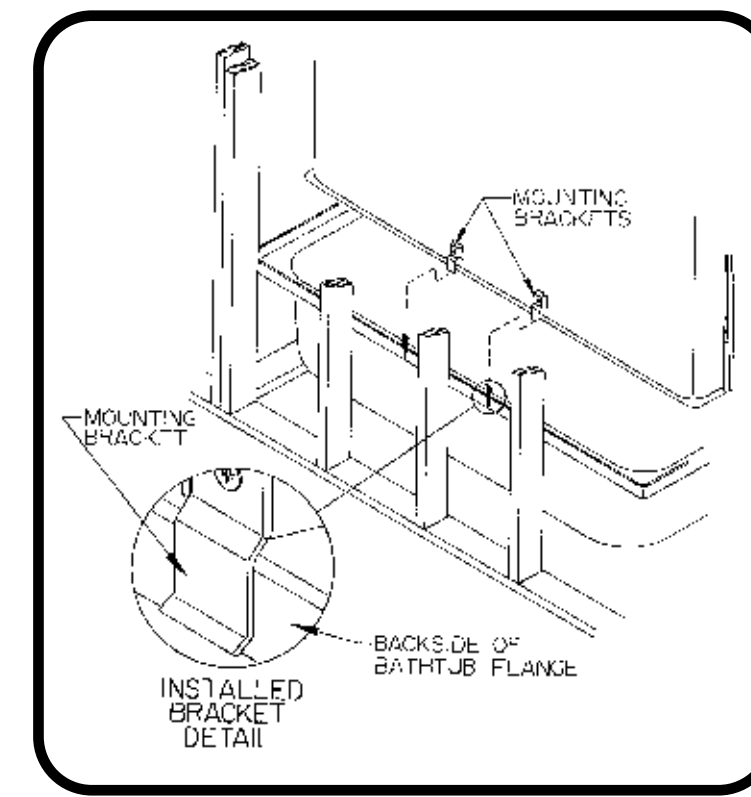

**Fig. F**

You are now ready to proceed with the permanent installation of your bathtub wall unit.

**BATH TUB WALL INSTALLATION**

Trial fit the Center Panel and both right and left Side Panels in place before applying any adhesive or mounting screws. Be sure to check alignment of the front edges of the Side Panels with the front surface of the bathtub threshold as shown in drawing, Fig. G.

If any gap is present between backside of mounting flange and face of stud, a tapered piece of wood (shim) may be used to fill the gap. Install “deck” screws through shims during permanent installation.

Now that the Center and both Side Panels are aligned horizontally, level and vertically plumb in alcove, using two of the previously drilled 5/32” dia. holes in each panel as a guide,