

MONOGRAM 48" PROFESSIONAL GAS RANGETOP WITH 6 BURNERS AND GRIDDLE (NATURAL GAS)

ZGU486NDPSS

DIMENSIONS AND INSTALLATION INFORMATION (IN INCHES)

Professional rangetops offer a number of choices in size and rangetop configurations.

PRODUCT DIMENSIONS AND CLEARANCE

A 48"- or 54"-wide professional vent hood with a minimum 900 CFM is recommended for installation over this rangetop.

Clearances between rangetop and side wall or combustible material must be at least 12" on each side.

*The opening between a 4" high backsplash must be 36" to allow the rangetop to slide back against the wall.

WARNING

installations without a hood require 48" minimum to combustibles above the rangetop. A custom hood installation with exposed horizontal combustible surfaces must have an "auto-on" feature. Refer to hood installation instructions for specific hood clearances. The surface of the entire back wall above the countertop and below the hood must be covered with a non-combustible material such as metal, ceramic tile, brick, marble or other stone.

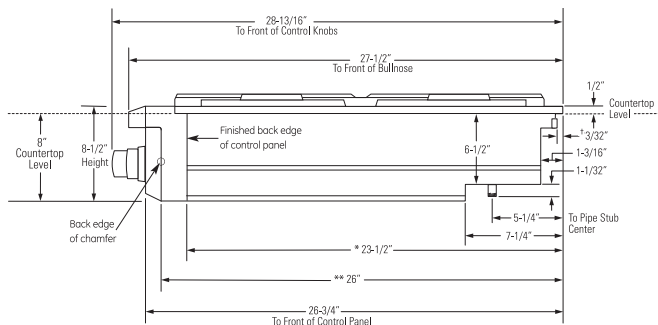
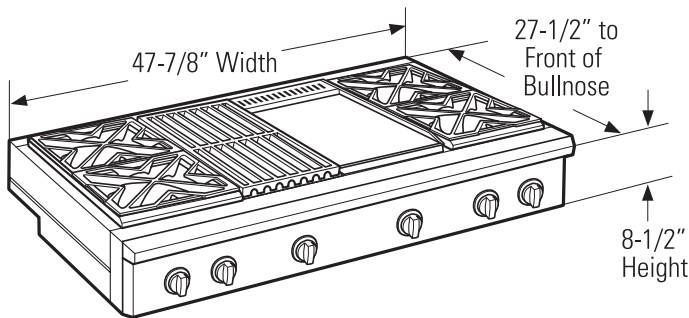

* Include the overhang of the rear trim when countertop continues behind the product. The overhang is decorative only. The weight of the rangetop is fully supported by the side trims.

* Minimum cabinet cutout depth from the back of the rear trim to the back finished edge of the control panel - typically, the minimum cabinet depth (front to back). Maximum cabinet cutout depth is 26" minus the countertop overhang.

** Maximum countertop cutout depth from the back of the rear trim to the back edge of chamfer at the sides of the control panel - typically, the maximum countertop cutout depth (front to back). Minimum countertop cutout depth is 25-1/4".

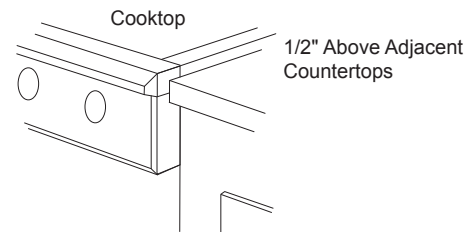
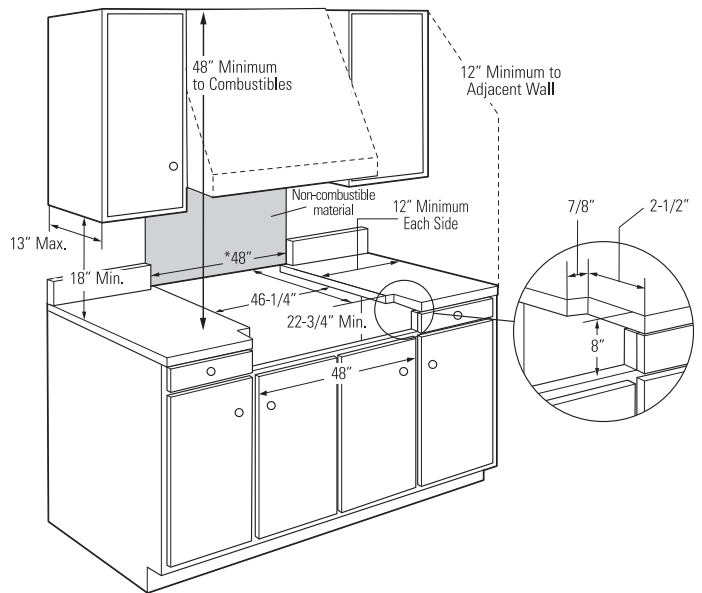

Front of deep cabinets can align with control panel beveled edge.

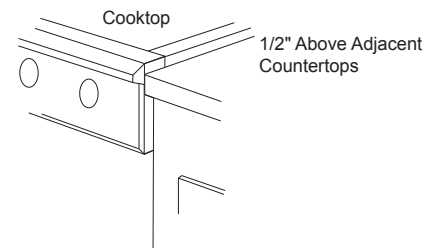

Front of deep cabinets can align with control panel beveled edge.

Allow 8" free space below the top surface of countertop. Allow additional clearances below the burner box to install the regulator and make house gas supply connections. Use a 90° elbow to route the gas connections and limit interference with drawers or other cabinetry.

ELEVATE EVERYTHING™

MONOGRAM

MONOGRAM 48" PROFESSIONAL GAS RANGETOP WITH 6 BURNERS AND GRIDDLE (NATURAL GAS)

ZGU486NDPSS

DIMENSIONS AND INSTALLATION INFORMATION (IN INCHES)

BACKSPLASH ACCESSORIES

The rangetop requires a 12" minimum clearance to a vertical combustible surface at the rear. A backsplash is required for installations with less than 12" clearance. A custom, non-combustible backsplash can be used.

BACKSPLASH WITH WARMING SHELF

All Monogram Professional Hoods feature infrared warming lights. The 30"-36" adjustable backsplash with warming shelf is a perfect complement when installed with the tapered or straight-sided hoods.

- Restaurant-Style Professional Hoods are shipped with a 22" stainless steel backsplash and warming shelf.

SIDE VIEW WITH A BACKSPLASH

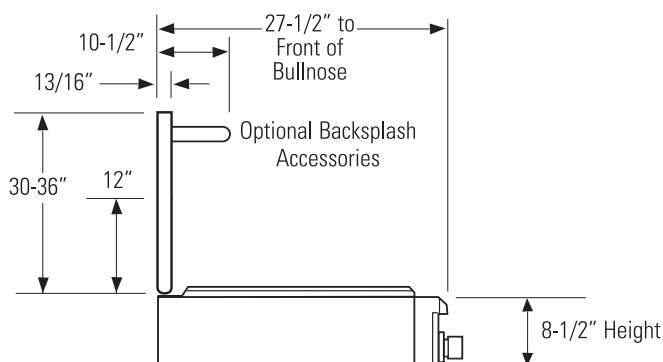

ADVANCE PLANNING FOR 48" PROFESSIONAL RANGETOPS

Professional rangetops offer a number of choices in size and rangetop configurations.

- All professional rangetops are factory set for natural gas. Conversion orifices for liquid propane are packed with product.

HIGH ALTITUDE KIT, WB28K10553,

is also available. The kits must be installed by a qualified service technician at additional cost.

Universal Utility Locations

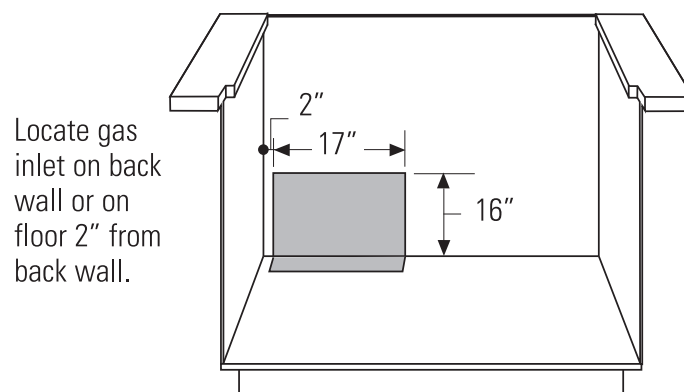

Locate gas inlet on back wall or on floor 2" from back wall.

ELECTRICAL REQUIREMENTS

Rangetops must be supplied with 120V, 60Hz, and connected to an individual, properly grounded branch circuit protected by a 15 amp circuit breaker or time-delay fuse.

GAS SUPPLY

- Natural gas models are designed to operate at 5" water column pressure. For proper operation, the pressure of the natural gas supplied to the regulator must be between 7" and 13" water column.
- If converted to liquid propane, the models are designed to operate at 10" water column pressure. For proper operation, the pressure of the LP source to the regulator must be between 11" and 13" water column.

ELEVATE EVERYTHING®

MONOGRAM

Product Specification Revised 10/18

MONOGRAM 48" PROFESSIONAL GAS RANGETOP WITH 6 BURNERS AND GRIDDLE (NATURAL GAS)

ZGU486NDPSS

FEATURES AND BENEFITS

AUTHENTIC PROFESSIONAL APPEARANCE
Stainless steel with smoothly finished edges and large electronic control knobs

SEALED, DUAL-FLAME STACKED BURNERS
Deliver a full spectrum of heat settings, from an ultra-low 140°F simmer to an intense 18,000 BTUs

STAINLESS STEEL AND ALUMINUM-CLAD GRIDDLE
Offers 18,000 BTUs* of cooking power, allowing fast and consistent heating across the entire cooking surface

ELECTRONIC IGNITION WITH AUTOMATIC REIGNITION
Ensures a continuous flame and reignites automatically if accidentally extinguished

REVERSIBLE BURNER GRATES
Are flat on one side and uniquely contoured on the other to accommodate round-bottom woks

STAINLESS STEEL GRIDDLE COVER
Included with the rangetop

A BAMBOO CUTTING BOARD
Is included

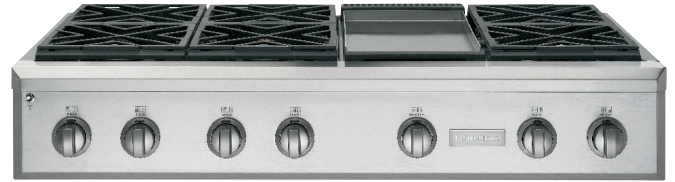

*Natural Gas

ELEVATE EVERYTHING™

MONOGRAM

Product Specification Revised 10/18