

Bradshaw™ Technical Specification

24" Double Towel Bar

DN3622

Stock Numbers:

- **DN3622BN – 24" Double Towel Bar**
Brushed Nickel
- **DN3622CH – 24" Double Towel Bar**
Chrome Finish
- **DN3622ORB – 24" Double Towel Bar**
Oil Rubbed Bronze

Materials:

Double Towel Bar post is die cast from the highest quality zinc alloy (Zamac). Casting is plated in chrome, brushed nickel or oil rubbed bronze. Towel bar is aluminum for brushed nickel and chrome finishes and brass for oil rubbed bronze.

Dimensions:

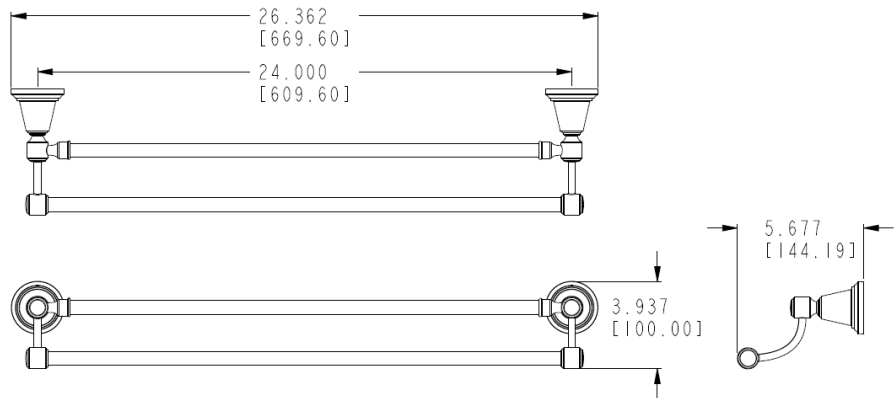

Installation Instructions:

1. Position the mounting template on the wall in the desired location.
2. Using a level, align the template and tape it to the wall.
3. Drill two 5/16" holes at each mounting post location that corresponds to your product.
4. Remove the template from the wall.
5. Fold ends of the plastic toggle together and insert into each hole in the wall.
6. Lightly tap anchors until flush with the wall.
7. One at a time, insert plastic pin into each of the anchors and lightly tap to activate anchor. Remove pin and repeat on all anchors.
8. Remove mounting posts from the product assemblies by loosening each setscrew.
9. Place the mounting plate on the wall over the installed wall anchors with "UP" facing you.
10. Insert screws through the mounting plate into the anchors. Tighten the screws.
11. Assemble the towel bar and posts.
12. While assembled, position each end post with setscrews facing down and place over both mounting posts. Tighten the setscrew at the bottom of each post.

Cleaning Instructions:

To preserve the fine finish of this product, clean only with a soft damp cloth. Dry well. Do not use commercial or abrasive cleaners.

Stock Number: _____ 24" Double Towel Bar
By Creative Specialties



25300 AL MOEN DRIVE • NORTH OLMSTED, OH 44070
CORPORATE HEADQUARTERS: (800) 321-8809 • FAX: (800) 848-6636
INTERNATIONAL: (440) 962-2000 • FAX: (440) 962-2726
CUSTOMER SERVICE (USA): 800-882-0116 • FAX: (888) 379-2720
WWW.MOEN.COM

©Copyright Creative Specialties International

Literature #BA1511