

DESCRIPTION

- One piece, chrome plated, cast brass construction above-deck
- M•Power™ soap dispensers available (models 8558 & 8560)
- Single mount
- Flexible stainless steel supply lines
- Vandal resistant below-deck box with included mounting hardware

OPERATION

- "Touch free" operation for improved hygiene
- Adjustable sensor activation distance from 3" to 12" (default 5-1/2")
- Vandal Mode: 30 second time-out feature
- Maintenance / Cleaning Mode: Allows for a 30 second deactivation for maintenance or cleaning
- Sentinel Flow: Eliminates stagnant water supply lines every 24 hours (factory setting = off)
- Metering Mode Feature: Adjustable run time from 10 to 180 seconds (factory setting = off)
- Battery 4(AA) with AC compatibility
 - For AC connection: Transformer 104630 required for up to 8 devices, and 182538 connector for each device
- Battery level indicator with low battery warning light
- Battery life: Up to 8 years*
- In-line filter included

STANDARDS

- Third party certified to meet ASME A112.18.1/CSA B-125.1, and all applicable requirements referenced therein including NSF 61/9 & 372
- Complies with California Proposition 65 and with the Federal Safe Drinking Water Act
- Meets the current requirements of the Buy American Act (BAA)
- ADA  compliant

WARRANTY

- Warranted for 5 years against material or manufacturer defects

* Typical alkaline battery life at 150 uses per day

Optional

**Adjustable Temperature
Thermostatic Mixing Valve**
104451

- Minimum flow rate of .35gpm
- ASSE 1070 & CSA B-125.3 certified

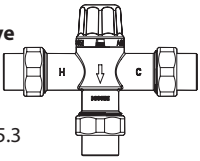



M•Power™ Non-Mixing & No Spout Gooseneck Electronic Faucet

Models: 8565

NOTE: THIS FAUCET IS DESIGNED TO BE INSTALLED THROUGH 1 HOLE, 1-1/4" MIN. DIA.

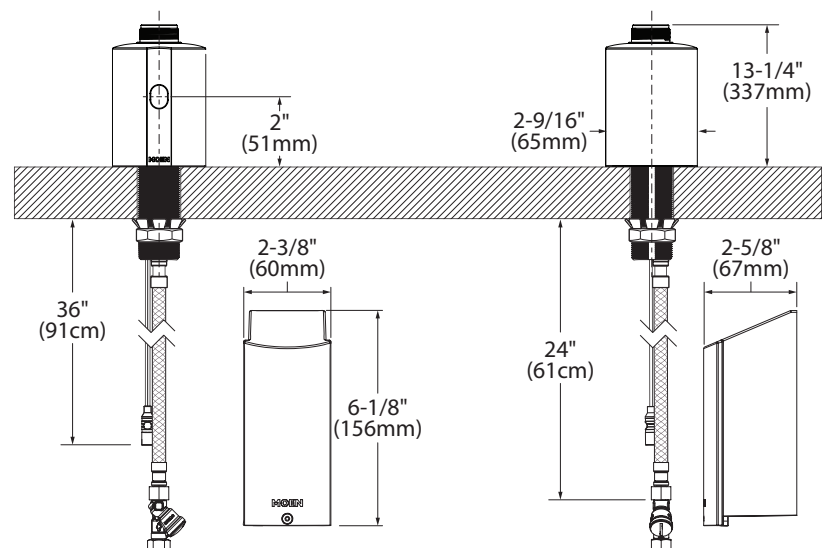

CRITICAL DIMENSIONS

(DO NOT SCALE)