

PRODUCT DESCRIPTION

- Battery powered, sensor activated, exposed water urinal flushometer with brass angle stop valve
- Brass construction with chrome plated finish
- Chloramine resistant seals
- 3/4" IPS inlet supply
- 3/4" top spud
- High back pressure vacuum breaker
- Intended for use with top spud urinals with matching flow rates as specified by the fixture manufacturer

OPERATION

- Self-cleaning Accuset™ piston flush technology
- Mechanical override
- Adjustable infrared sensor range up to 15"
- Four (4) Alkaline AA batteries included
- Battery life: Up to 8 years*
- Low battery indicator light
- Optional 24 hour Sentinel Flush (factory setting is off)
- Operating Pressure Range: 20-125psi

FLOW RATE

- 8312 (1.0gpf/3.8Lpf)
- 8315 (0.5gpf/1.9Lpf) - WaterSense® certified
- 8316 (0.125 gpf/0.5Lpf) - WaterSense® certified

STOP VALVE

- All metal 3/4" IPS vandal resistant angle stop with double o-ring connection
- Adjustable installation (left or right connection)

STANDARDS

- Third party certified by IAPMO and CSA to meet ASME A112.19.2M and all applicable requirements referenced therein and complies with requirements of ASSE 1037
- BAA
- ADA 

WARRANTY

- Warranted for 5 years against material or manufacturing defects

*Typical alkaline battery life at 130 uses per day is about 8 years

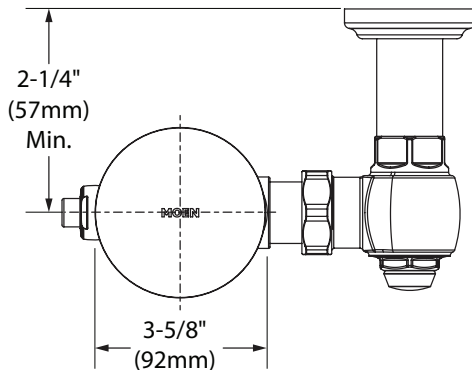

CRITICAL DIMENSIONS

(DO NOT SCALE)



M-POWER™ 3/4\" data-bbox="641 279 942 335"/>

Models: 8312, 8315, 8316

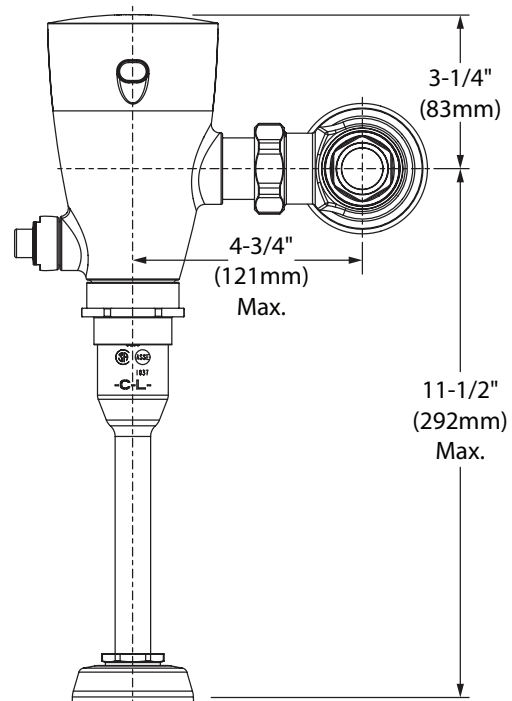

PRODUCT DESCRIPTION

- Brass construction w/chrome plated finish
- 3/4" IPS supply
- 3/4" top spud

OPERATION

- Adjustable sensor eyes
- Battery powered (4) standard AA (included)
- Average battery life 250,000 cycles
- Self-diagnostic electronics
- Piston flushing mechanism
- Self cleaning filter system
- Low battery indicator light

FLOW

- Operating pressures 10 to 125 psi
- 0.5 gpf/1.9Lpf (gallons per flush)
- 24 hour sentinel flush
- Manual override button

VALVES

- 3/4" IPS angle stop (vandal resistant)
- Adjustable installation (left or right connection)

STANDARDS

- Third party certified by IAPMO and CSA to meet Watersense®, ASME A112.19.2M and all applicable requirements referenced therein and complies with requirements of ASSE 1037

- **ADA** 

WARRANTY

- Warranted for 5 years against material or manufacture defects.

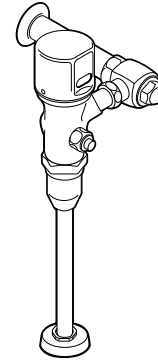

3/4" Battery Powered Exposed Style Urinal Flush Valve

Model: 8315

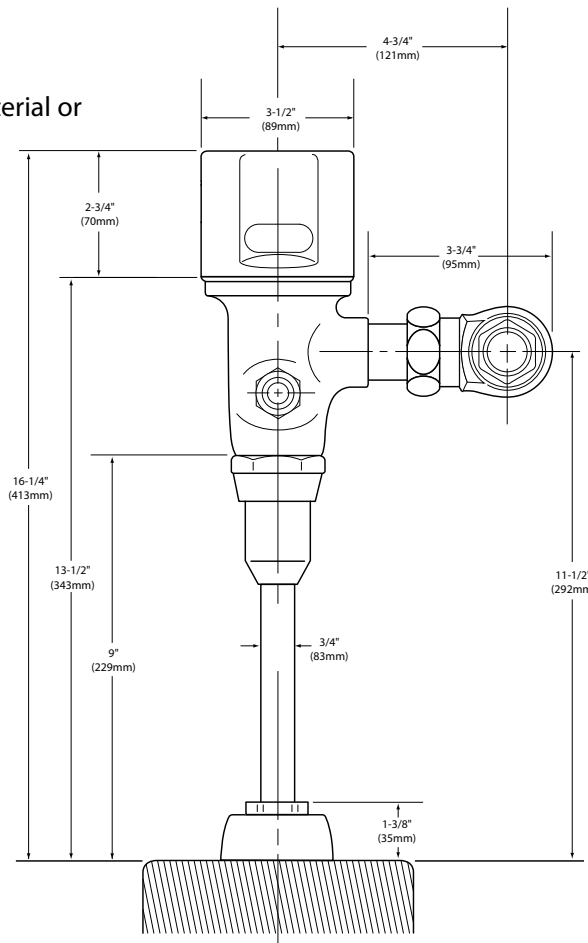

CRITICAL DIMENSIONS

(DO NOT SCALE)