

DGC 6500-1

Steam oven with full-fledged oven function and XL cavity combines two cooking techniques - steam and convection.



- Perfect results thanks to MultiSteam technology
- Plenty of space to be creative - the XL cooking compartment
- Very convenient - water container is behind motorized fascia panel
- Custom and precise temperature control - cook with the food probe
- A plus for convenience - SensorTronic

EAN: 4002515646014 / material number: 10256670

Construction type	
Combination steam oven	•
Design	
ContourLine	•
Appliance color	Clean Touch Steel
Control panel	SensorTronic
Convenience features	
Electronic temperature control of oven in °F	85-435
Electronic temperature control of steam oven in °F	105-212
External steam generation	•
Climate sensor	•
Individual humidity settings in combination cooking	•
Menu cooking without transfer of taste	•
Roast probe	•
Keep-warm function	•
Automatic programs with individual setting of the cooking result	•
Operating modes	
Defrost	•
MasterChef automatic programs	More than 200
Combi cooking	•
Steam cooking	•
Sous-vide	•
Reheating	•
Broil	•
Convection Bake	•
Intensive bake	•
Cake plus	•
Surround	•
Browning	•
Bake	•
Convection Broil	•
Special modes	•

DGC 6500-1

Steam oven with full-fledged oven function and XL cavity combines two cooking techniques - steam and convection.



Control panel	
MultiLingua	•
Steam cooking on up to 3 levels at the same time	•
Motorized lift-up fascia	•
Automatic menu cooking	•
Quantity-independent cooking	•
Steam reduction before end of program	•
Time of day display	•
Date display	•
Minute minder	•
Time buffer in h	200
Start-stop programming	•
Automatic switch-off	•
Entry via number keypad	•
Actual temperature display	•
Acoustic signal when desired temperature is reached	•
Favorites	20
Sabbath program	•
Individual settings	•
Door	
CleanGlass door	•
Door with viewing screen	•
Door hinge side	Bottom
Cavity	
XL cavity	•
Cavity volume in cu.ft(l)	1.84 (52)
PerfectClean stainless steel cavity	•
No. of rack levels	3
Labeling of rack levels	•
Removable side racks with PerfectClean	•
No. of halogen lamps	1
Cleaning convenience	
Stainless steel front with Clean Touch Steel surface	•
Cavity with PerfectClean	•
External steam generator	•
Soak program	•
Rinse program	•
Cavity drying program	•
Quick-release side racks	•
Automatic descaling	•
Steam technology and water supply	
MultiSteam	•
Water reserve for approx. 90 min cooking	•
Lightweight water container	•
Condensate container behind motorized fascia panel	•
Drain filter	•
Efficiency and sustainability	
Energy-saving lighting circuit	•
Rapid Pre-Heat	•
Appliance networking	
Miele@home	•

DGC 6500-1

Steam oven with full-fledged oven function and XL cavity combines two cooking techniques - steam and convection.



Safety	
Appliance cooling system with cool touch front	•
Safety cut-out	•
System lock	•
Vapor cooling system	•
Door contact switch	•
Technical data	
Niche depth in in. (mm)	21 7/8 (555)
Appliance width in in.(mm)	23 1/2 (595)
Appliance height in in.(mm)	18 (456)
Appliance depth in in.(mm)	22 5/8 (573)
Weight in lbs. (kg)	94 (42.5)
Usable voltage range in V	240/208
Fuse rating in A	20
Number of phases	2
Standard accessories	
No. of universal baking trays with PerfectClean	1
Combi rack with PerfectClean	1
Side racks with PerfectClean	•
No. of perforated stainless steel containers	1
No. of unperforated stainless steel containers	1
Grease filter	•
Connection wire with plug	•
Descaling tablets	•

DGC 6500-1

Steam oven with full-fledged oven function and XL cavity combines two cooking techniques - steam and convection.

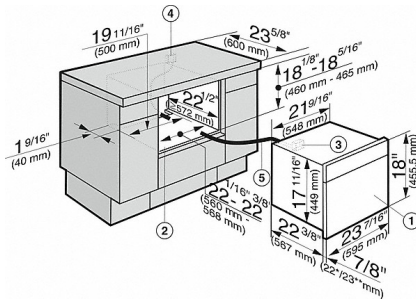

DGC 6000 XL in a floor unit, CLST (Installation drawing) - USA

- * Appliances with glass front
- ** Appliances with metal front
- 1) Steam oven
- 2) Niche
- 3) Pass-through for the power cord
- 4) Recommended position for electrical Connection
- 5) Power cord

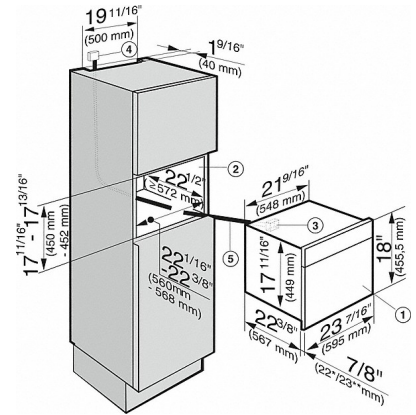

DGC 6000 XL in a tall unit, CLST (Installation drawing) - USA

- * Appliances with glass front
- ** Appliances with metal front
- 1) Steam oven
- 2) Niche
- 3) Pass-through for the power cord
- 4) Recommended position for electrical Connection
- 5) Power cord

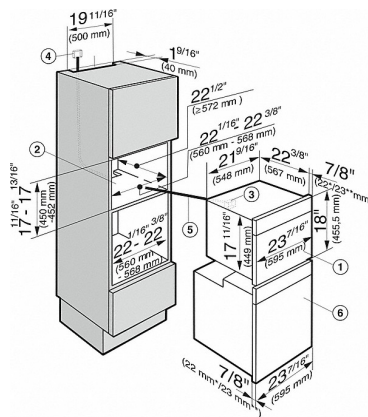

DGC 6000 XL in a tall unit with oven (Installation drawing) - USA

- * Appliances with glass front
- ** Appliances with metal front
- 1) Steam oven
- 2) Niche
- 3) Pass-through for the power cord
- 4) Recommended position for electrical Connection
- 5) Power cord
- 6) Oven

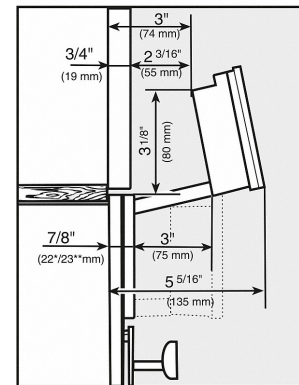

DGC 6000 XL (detailed installation drawing of open control panel) - USA

DGC 6500-1

Steam oven with full-fledged oven function and XL cavity combines two cooking techniques - steam and convection.

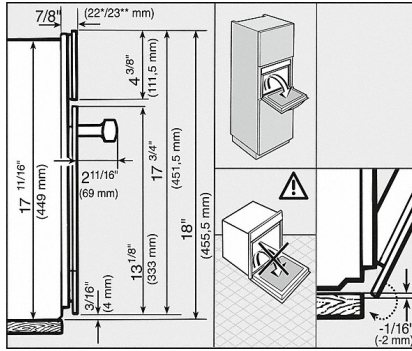

DGC 6000 XL (detailed installation ContourLine) - USA

- * Appliances with glass front
- ** Appliances with metal front