

PLUMBING CONNECTION

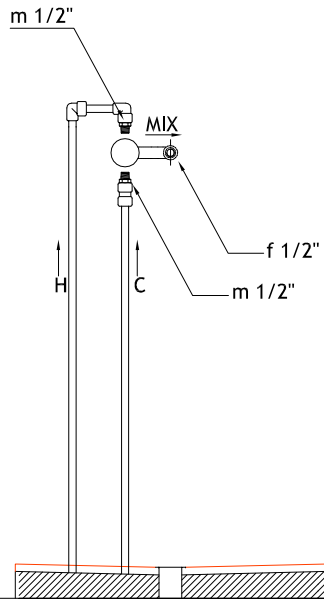

WALL DETAILS (After Plumbing)

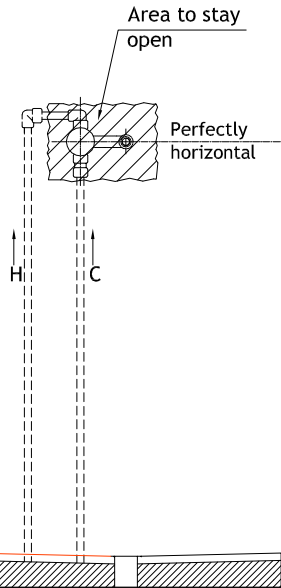

DETAILS FOR WALL COVERING

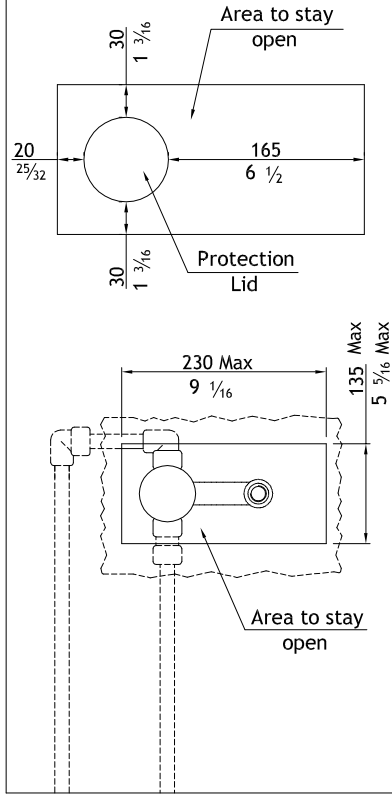

RECOMMENDED POSITIONS

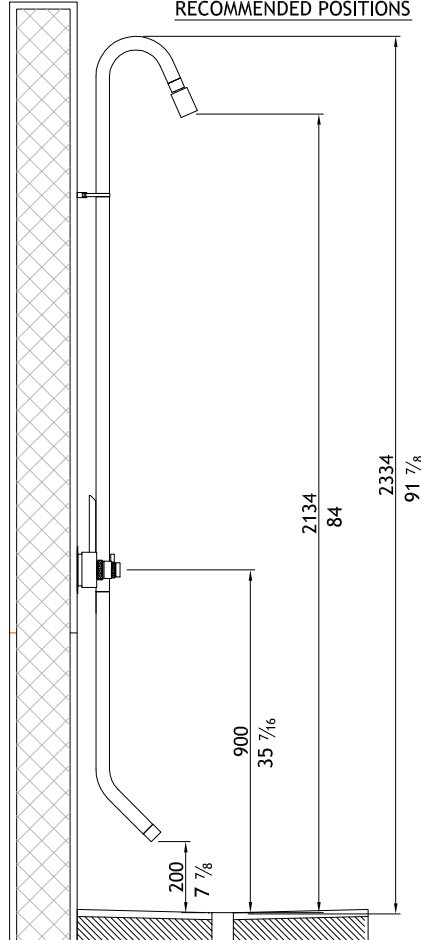

FRONT VIEW

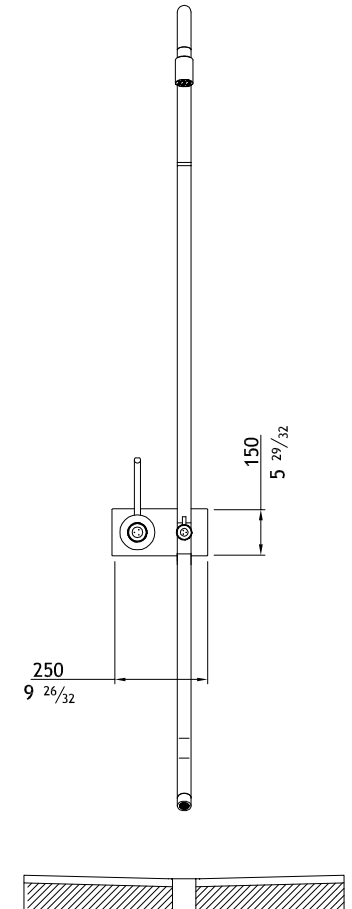

WARNING

- 1- The thermostatic mixer body must be installed so that the reference line on the protection lid will correspond to the future finished wall level; (check that protection lid is fully screwed on)(Fig.1).
- 2- Check that thermostatic mixer body and protection lid are perfectly horizontal.
- 3- Never close output nozzle. For testing check however that valve is closed.

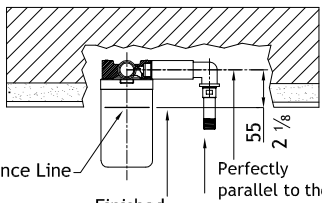
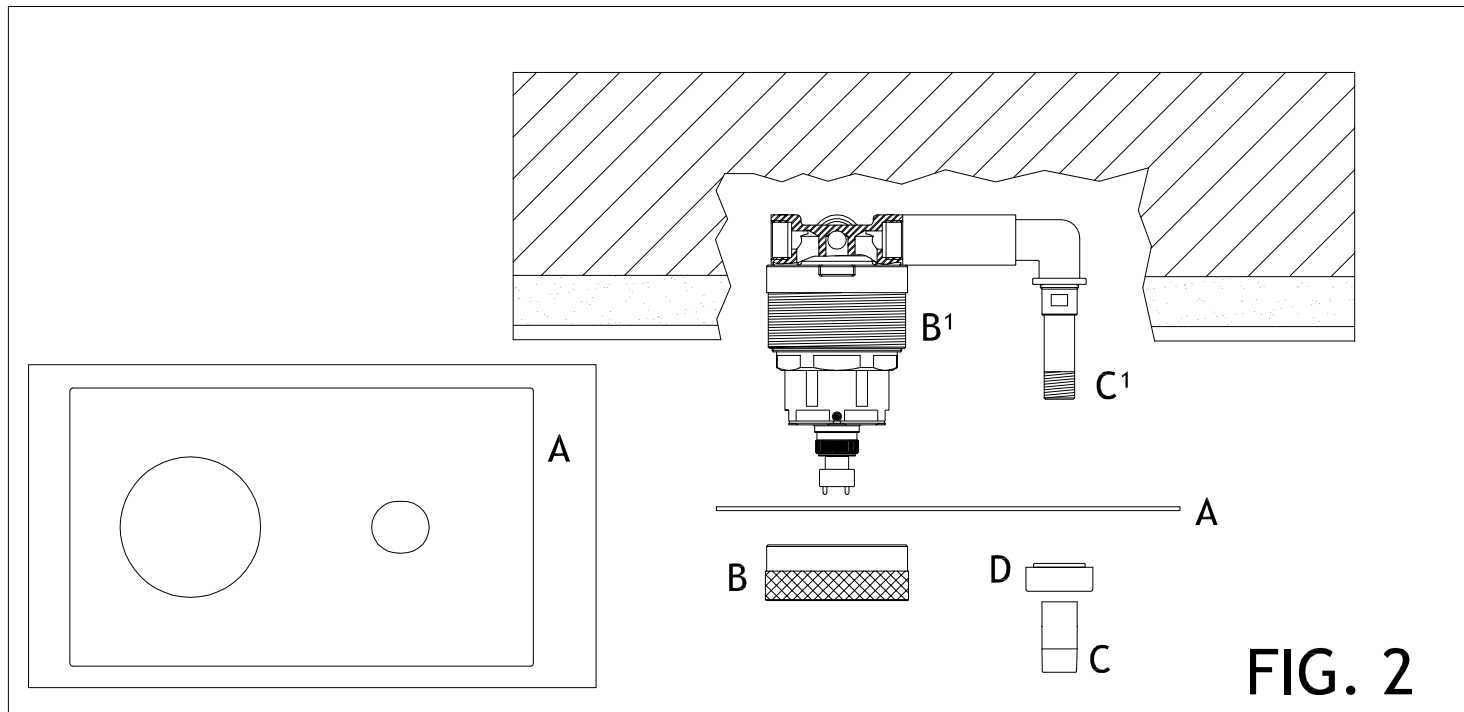
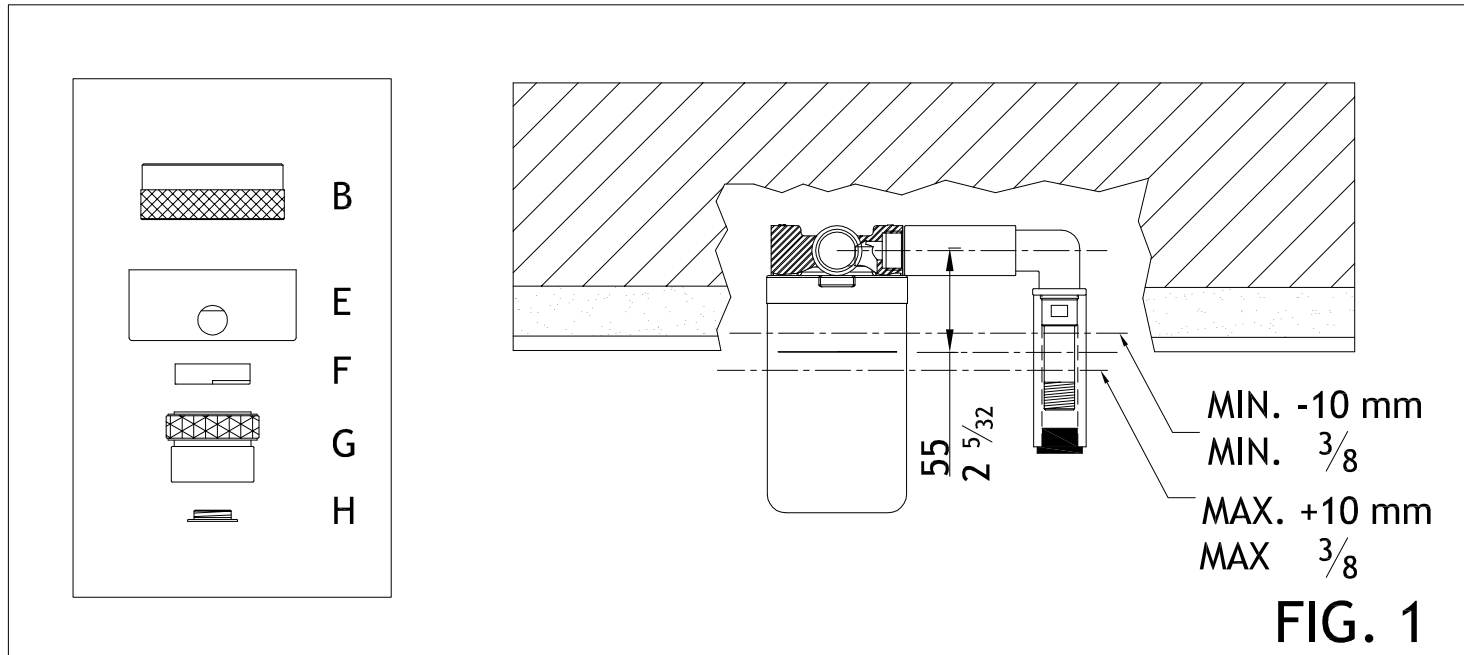

Fig.1

MGS Progetti srl

Corso Milano,189 - 28883 Gravellona Toce (VB) - Italy

www.mgstaps.com - E-mail: info@mgstaps.com - Tel.:+39 0323 865218 - Fax:+39 0323 865215



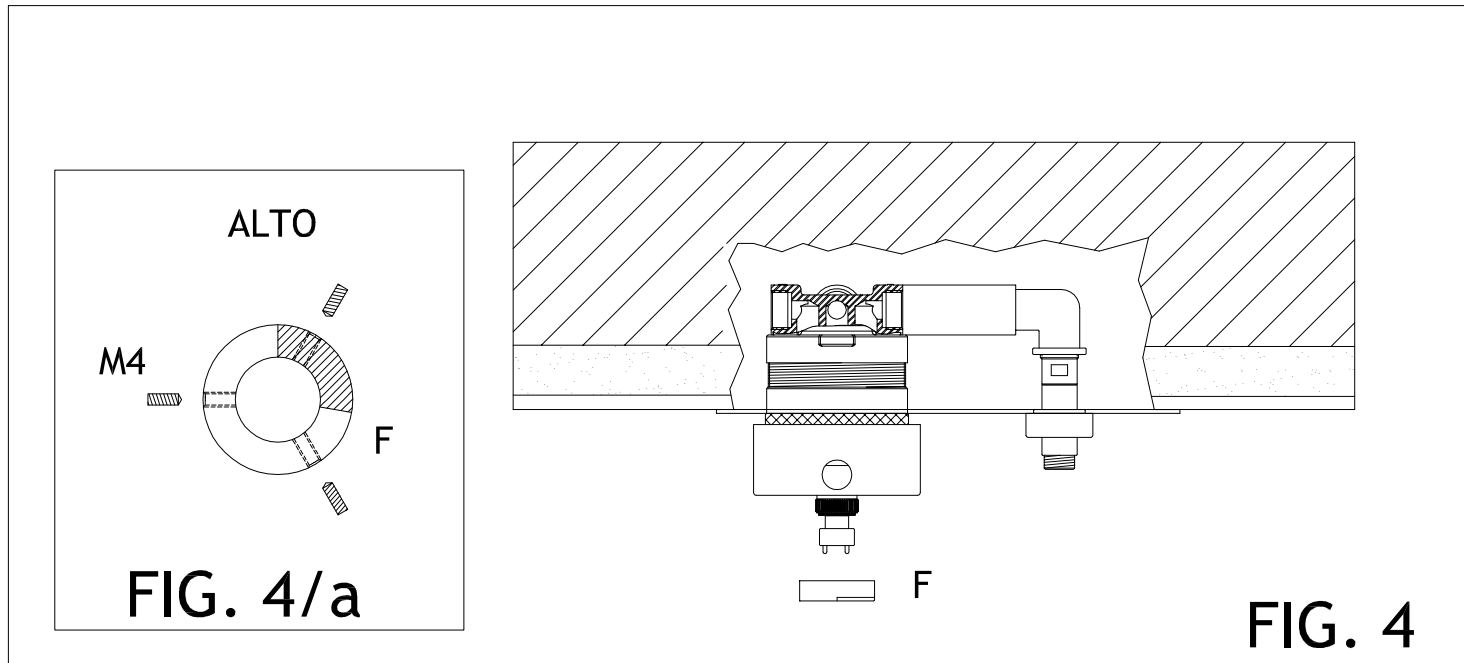
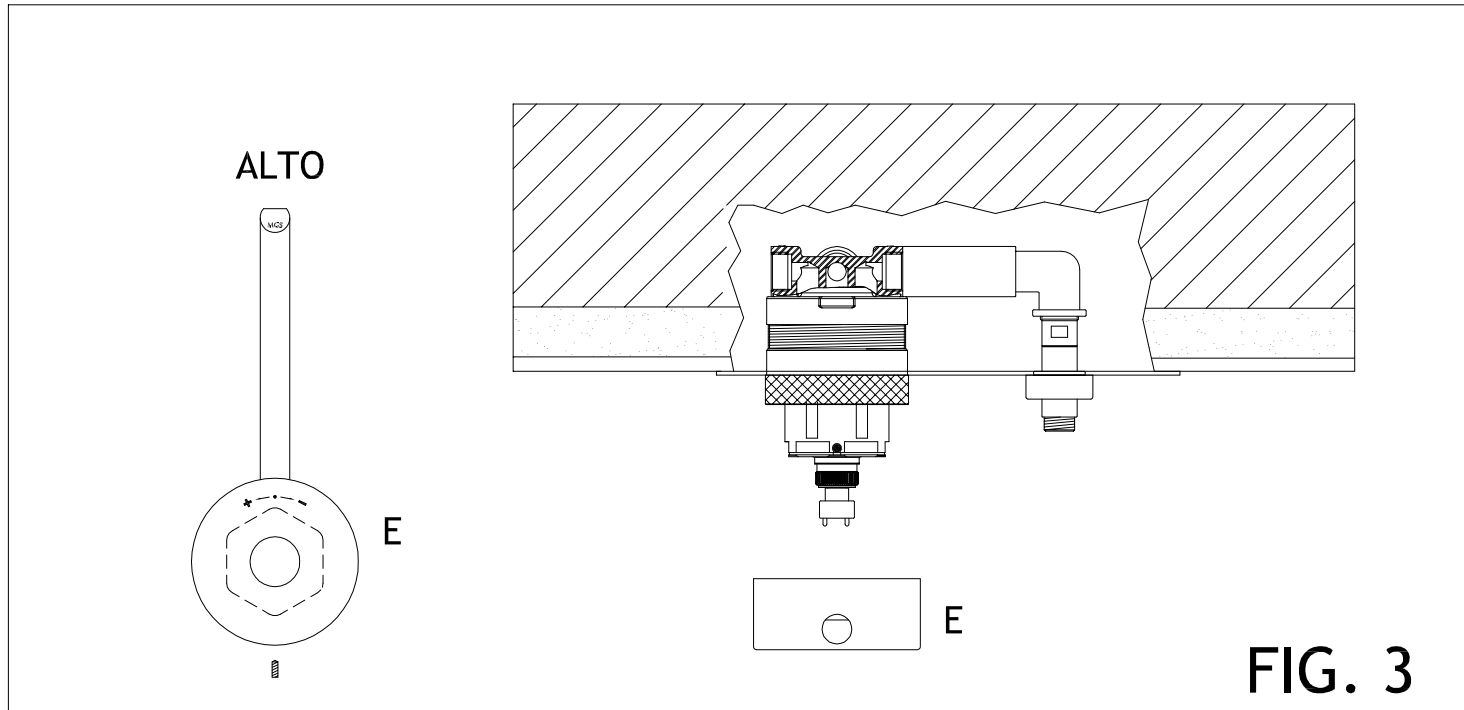

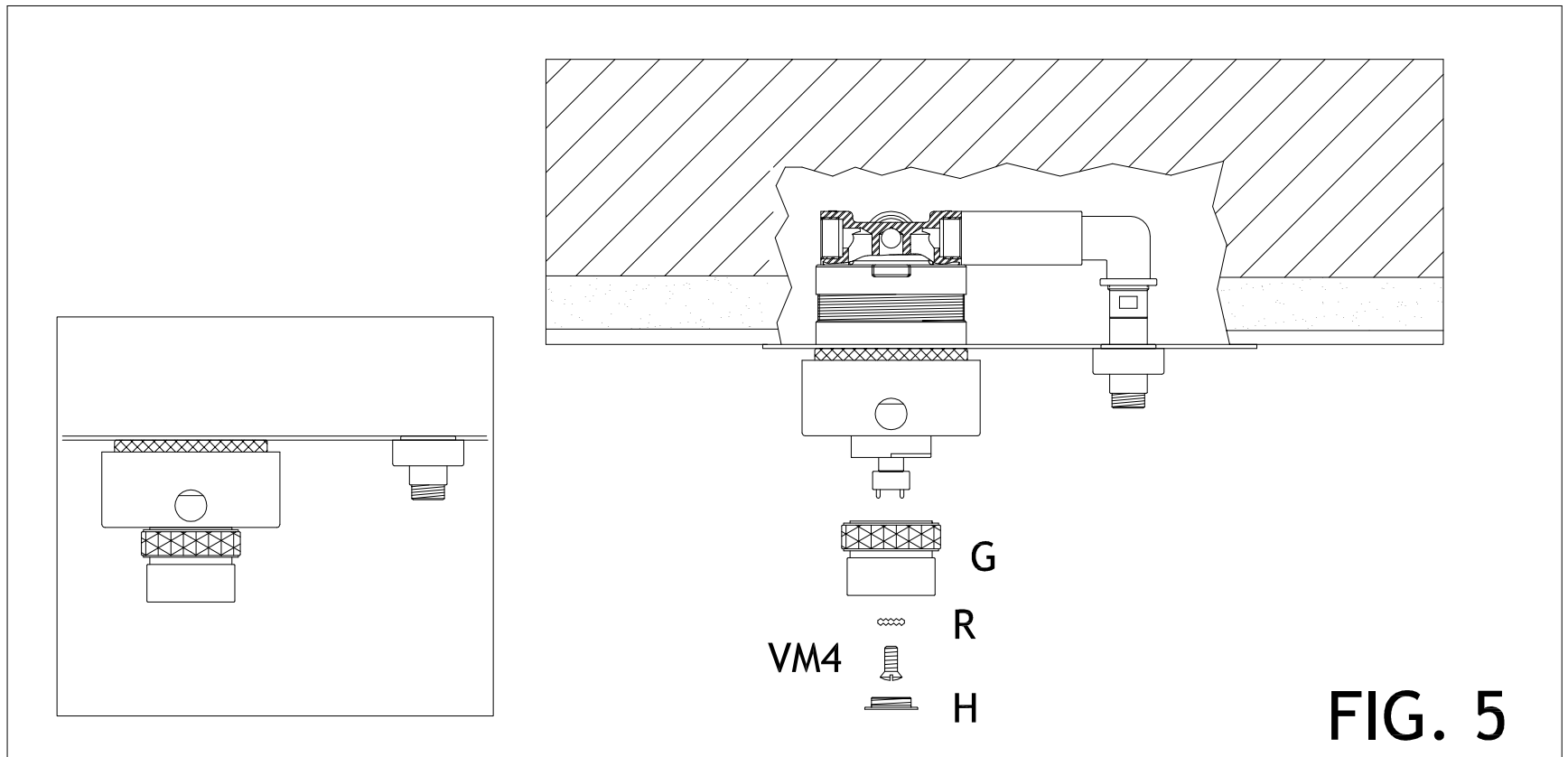

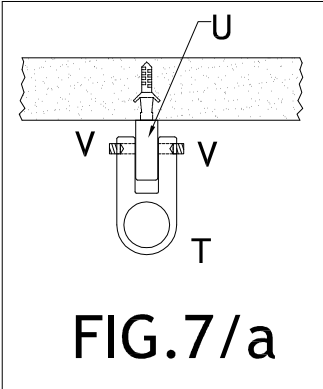
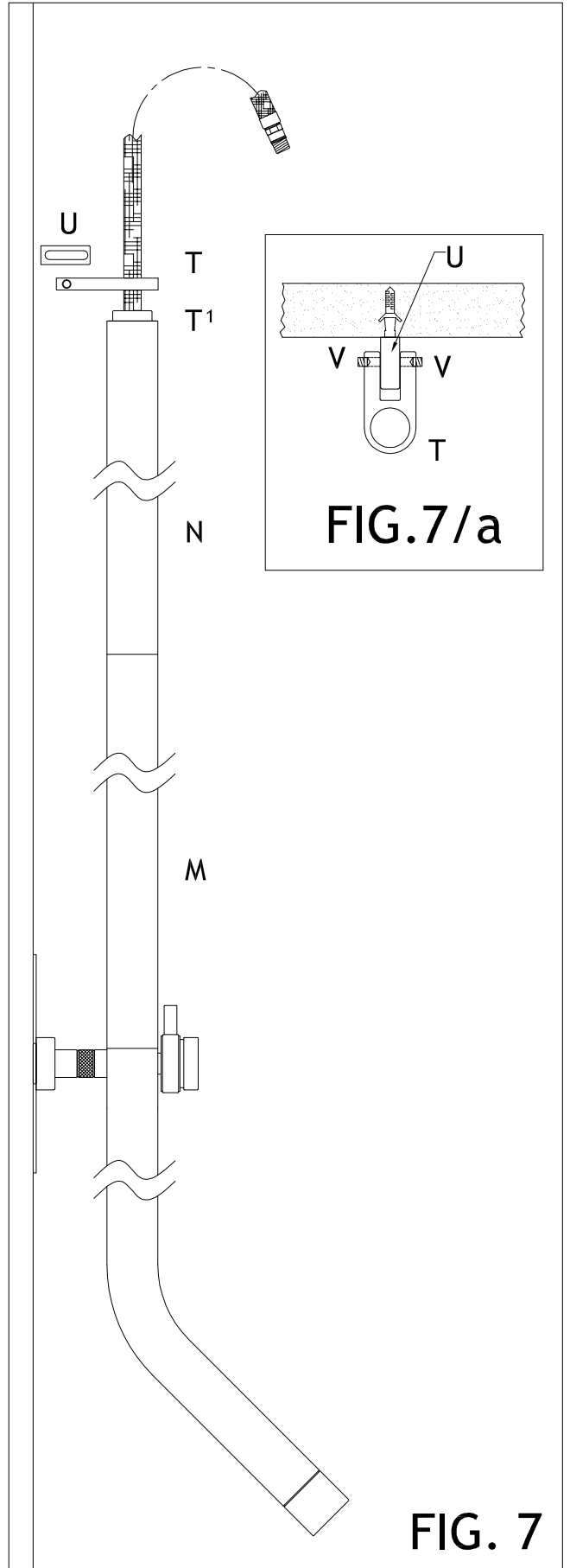
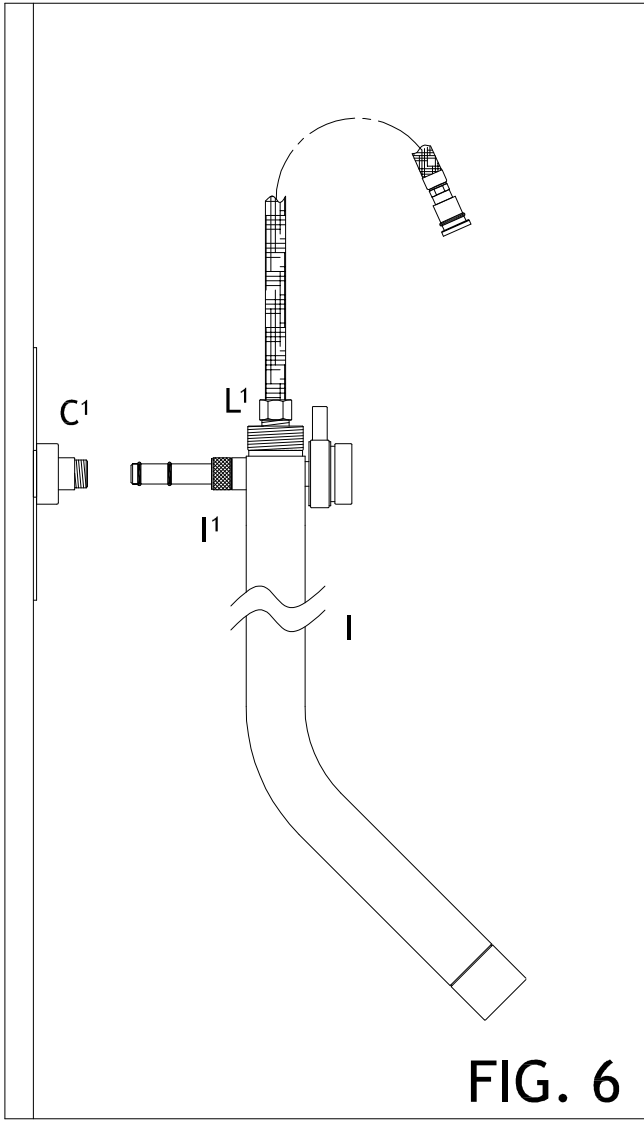

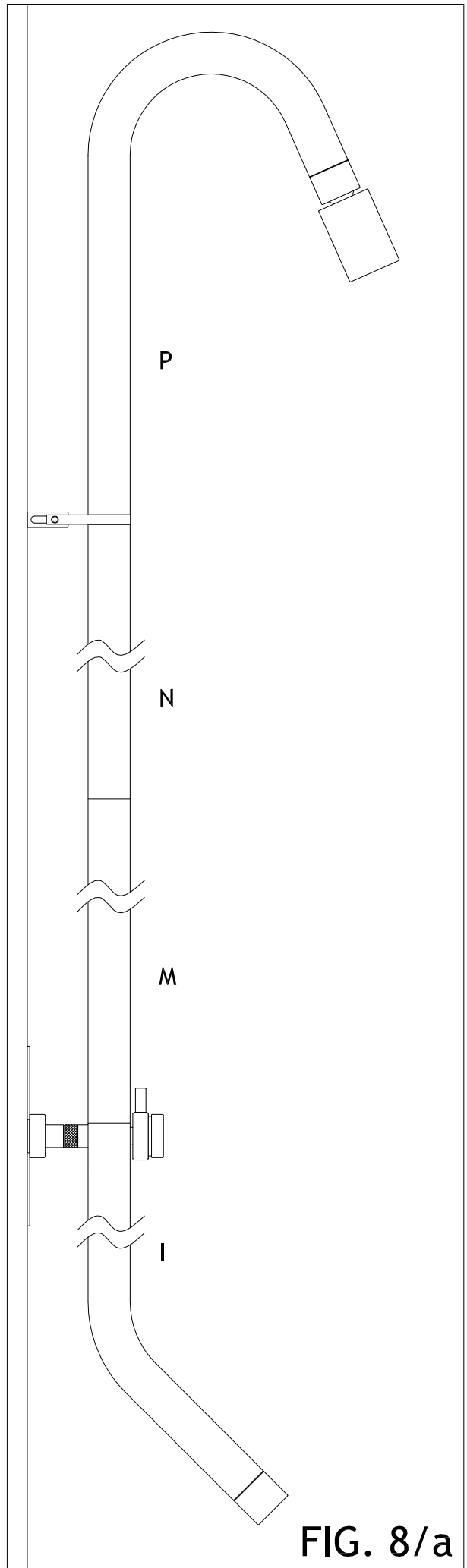
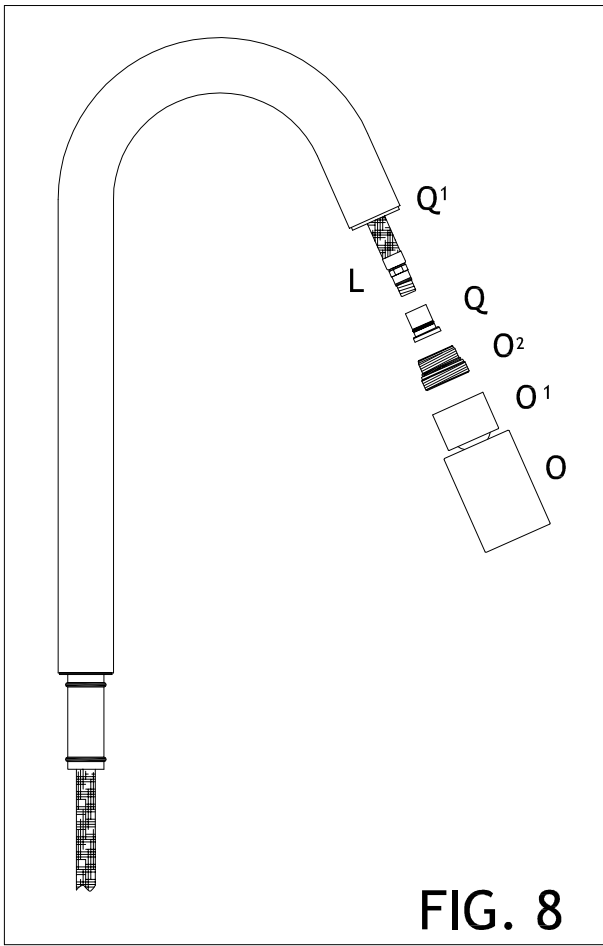

ASSEMBLY INSTRUCTIONS THERMOSTATIC SHOWER COLUMN WITH FOOT WASH CB447

1/2

FIRST STEP

Remove various parts from the carton with extreme care.

Handle Body (E) – Knob (G) – Cover (H) – CAM (F) – Ring (B)

Check on the wall that the built-in thermostatic valve is clean and that installation has been made correctly according to our separate pre-assembly instructions. In particular, check that the coloured line indicated on the plastic protection lid is positioned +/-10 mm with respect to the wall level (FIG 1) and that the shower finishing plate covers wall cutting area.

At this point remove (by unscrewing) plastic protection lid from the valve body and the protective sleeve from output nozzle.

IMPORTANT: make sure that the valve is closed by fully turning its plastic body clockwise

ASSEMBLY OF MAIN HANDLE WITH THERMOSTATIC CONTROL

(FIG 2)

- Place finishing plate (A) on valve body (B') and nozzle (C') pushing it against the wall.
- Fully screw ring (B) to body (B') keeping patterned area on the outside which will block the ring to the finishing plate.
- Fully screw tube (c) onto nozzle (c') and the threaded part will reappear.
- Slide centring ring (D) on tube (c) until the reduced diameter disappears into the finishing plate.

(FIG 3)

Push handle (E) on the valve by keeping lever in vertical position (valve is closed).

ATTENTION: Check that the handle is fully pushed in.

(FIG 4)

Insert cam (F) on the large broach of the valve and block to the handle with the 3 allen screws M4 as per (FIG 4A).

(FIG 5)

- Place knob (G) on the valve's central shaft and rotate until the 3 pins appear through the holes.
- Tighten firmly with screw M4 after positioning washer (R).
- Close by screwing cover (H) on the handle through enclosed 3 pin tool.

CHANGING WATER TEMPERATURE AT STOP POSITION

Cam (F) in default position (FIG 4A) determines with an anticlockwise rotation of the knob, a stop point corresponding to a comfortable warm water temperature. To increase water temperature pull the patterned ring of the knob and continue anticlockwise rotation. By inverting to clockwise rotation the stop point will fall back into position.

To change temperature stop point, remove knob (G) (FIG 5), loosen 3 allen screws (FIG 4a) and change position of cam (F) (FIG 4). Rotate towards left for warmer water and towards right for colder water.

ASSEMBLY INSTRUCTIONS THERMOSTATIC SHOWER COLUMN WITH FOOT WASH CB447

2/2

ASSEMBLY OF FOOT WASH

(FIG 6)

- Fully push foot wash (I) into connection (C') taking care of not damaging O-Ring gaskets.
- Tighten the assembly through ring (I').
- Tighten flexible hose (L) to (L').

COLUMN ASSEMBLY

(FIG 7) (FIG 7/a)

- Screw tube (N) to (M) and this assembly onto spout block (I).
- Insert flexible hose into the hole of bracket (T) and place bracket onto socket (T1).
- Check that I-M-N are in correct vertical position and then fix block (U) to the wall.
- Tighten two screws (V) with allen key N° 3 (enclosed).

ASSEMBLY OF SHOWER HEAD CURVE

(FIG 8) (FIG 8/a)

- Unscrew and remove part (Q) from the end of flexible hose (L).
- Disassemble swivel head from shower curve (P) unscrewing (O').
- Unscrew and remove part (O2).
- Insert shower curve (P) into upper column (N) without damaging the gaskets.
- Pull out flexible hose (L) from point (Q') and fully push curve (P) into column (N).
- Screw back into position part (Q) to flexible hose (L) and fully push into (Q1).
- Screw back into position part (O2) and (O1).