

FY-952C

FY-952BN



50/50 Pop-Up Assembly



FEATURES & BENEFITS

- 50/50 Pop-Up Assembly

FY-952C
Chrome Finish

FY-952BN
Brushed Nickel Finish

APPROVALS:

Meets or Exceeds The Following:

- * ANSI/ASME A112.18.2
- * IAPMO/cUPC



CALIFORNIA:
TEXAS:
NEW YORK:

TEL: 866-532-8306
TEL: 800-935-5456
TEL: 800-431-2082

FAX: 866-532-8307
FAX: 800-683-4247
FAX: 800-640-2252

Visit Our Web Site : www.matco-norca.com

Product Spec Sheet

□ **FY-952C**

□ **FY-952BN**



50/50 Pop-Up Assembly

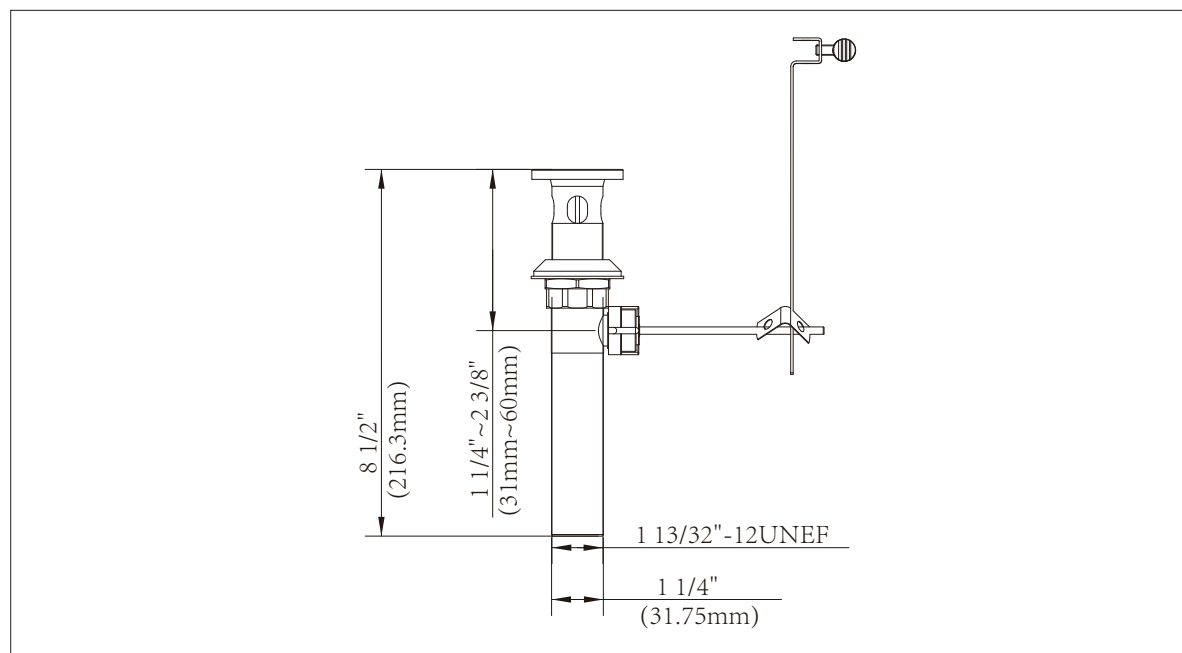
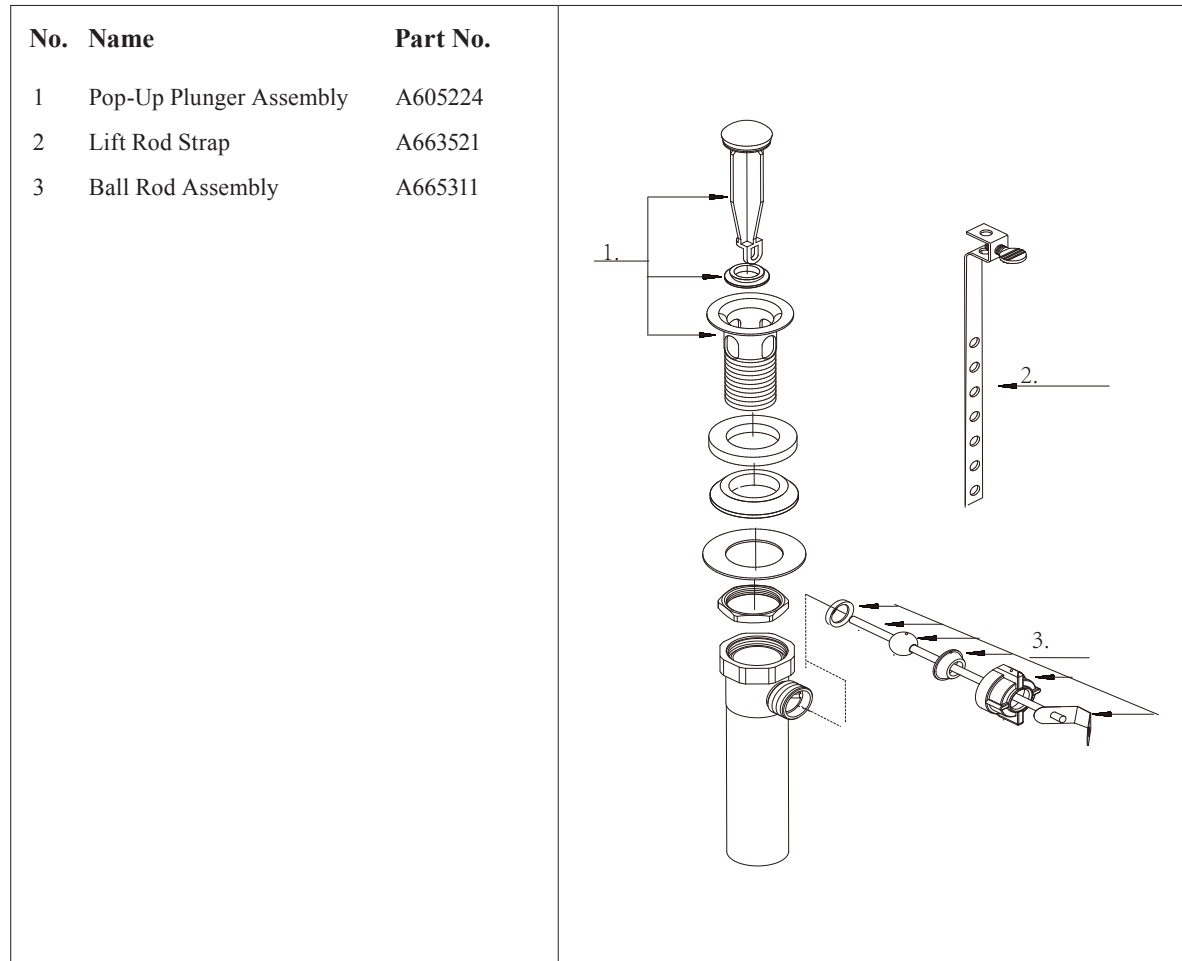

Product Spec Sheet

CALIFORNIA:
TEXAS:
NEW YORK:

TEL: 866-532-8306
TEL: 800-935-5456
TEL: 800-431-2082

FAX: 866-532-8307
FAX: 800-683-4247
FAX: 800-640-2252

Visit Our Web Site : www.matco-norca.com