

LF Dielectric Union - Female X Sweat • Spec Sheet



*Product will have LF imprinted on the body for Lead Free

FEATURES & BENEFITS

- Lead Free Brass*
- 250 PSI @ 80°F; 125 PSI @ 180°F
- Sizes 1/2" - 2"

DIMENSIONS

Part #	Size	A	B	C	D	E
DUN-0509LF	1/2"	1.42	1.00	0.77	1.87	0.83
DUN-7559LF	3/4" X 1/2"	1.62	1.26	0.77	1.87	0.83
DUN-0759LF	3/4"	1.62	1.26	0.77	2.11	1.06
DUN-1009LF	1"	1.89	1.50	0.87	2.32	1.30
DUN-1259LF	1-1/4"	2.25	1.81	0.91	2.58	1.58
DUN-1509LF	1-1/2"	2.76	2.13	0.95	2.80	1.81
DUN-2009LF	2"	3.51	2.60	1.06	3.11	2.36

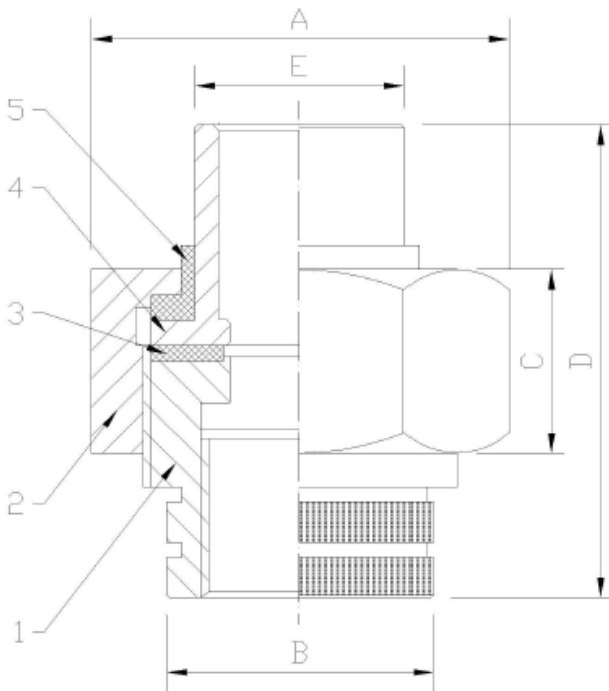

MATERIAL SPECIFICATIONS

No.	Part	Material
1	IPS Connection	Zinc Coated Cast Steel
2	Nut	Zinc Coated Cast Steel
3	Gasket	EPDM
4	Solder Connection	Brass
5	Insert	Nylon

*This product complies with 0.25% weighted average lead content on wetted surfaces in accordance with the Safe Drinking Water Act (SDWA) / Federal Public Law No. 111-380.



CALIFORNIA 5593 Fresca Dr., La Palma CA 90623
TEXAS 1150 Silber Rd., Houston TX 77055
ILLINOIS 278 Windy Point Dr., Glendale Heights, IL 60139
NEW YORK PO Box 27, Rt.22, Brewster NY 10509
 WEB: www.matco-norca.com

• Phone: 866-532-8306 • Fax: 866-532-8307
 • Phone: 800-935-5456 • Fax: 713-680-2999
 • Phone: 844-412-5068 • Fax: 800-640-2252
 • Phone: 800-431-2082 • Fax: 845-278-9056
 EMAIL: mail@matco-norca.com

LF Dielectric Union - Male X Sweat • Spec Sheet



FEATURES & BENEFITS

- Lead Free Brass*
- 250 PSI @ 80°F; 125 PSI @ 180°F
- Sizes 1/2" & 3/4"

DIMENSIONS

Part #	Size (F)	A	B	C	D	E	G
DUN-0509MLF	1/2"	1.42	1.00	0.77	2.78	0.83	0.63
DUN-759MLF	3/4"	1.62	1.26	0.77	3.05	1.06	0.88

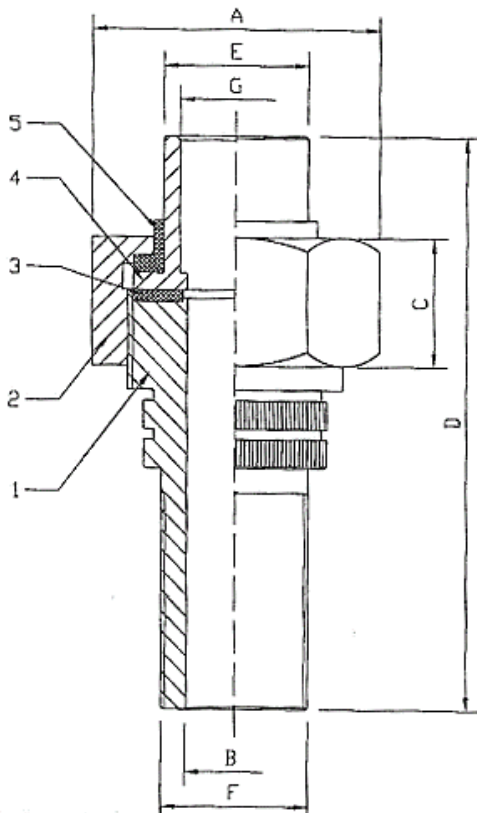

MATERIAL SPECIFICATIONS

No.	Part	Material
1	IPS Connection	Zinc Coated Cast Steel
2	Nut	Zinc Coated Cast Steel
3	Gasket	EPDM
4	Solder Connection	Brass
5	Insert	Nylon

*This product complies with 0.25% weighted average lead content on wetted surfaces in accordance with the Safe Drinking Water Act (SDWA) / Federal Public Law No. 111-380.



CALIFORNIA 5593 Fresca Dr., La Palma CA 90623
TEXAS 1150 Silber Rd., Houston TX 77055
ILLINOIS 278 Windy Point Dr., Glendale Heights, IL 60139
NEW YORK PO Box 27, Rt.22, Brewster NY 10509
 WEB: www.matco-norca.com

• Phone: 866-532-8306 • Fax: 866-532-8307
 • Phone: 800-935-5456 • Fax: 713-680-2999
 • Phone: 844-412-5068 • Fax: 800-640-2252
 • Phone: 800-431-2082 • Fax: 845-278-9056
 EMAIL: mail@matco-norca.com

LF Dielectric Union - Female X BPT • Spec Sheet



FEATURES & BENEFITS

- Lead Free Brass*
- 250 PSI @ 80°F; 125 PSI @ 180°F
- Sizes 1/2" - 2"

DIMENSIONS

Part #	Size	A	B	C	D	E
DUN-EA03LF	1/2"	1.62	1.02	0.77	2.21	1.02
DUN-EA04LF	3/4"	1.89	1.26	0.77	2.21	1.26
DUN-EA05LF	1"	2.25	1.50	0.87	2.52	1.46
DUN-EA06LF	1-1/4"	2.76	1.81	0.91	2.72	1.85
DUN-EA07LF	1-1/2"	3.51	2.13	0.91	2.76	2.13
DUN-EA08LF	2"	4.14	2.60	1.10	3.11	2.60

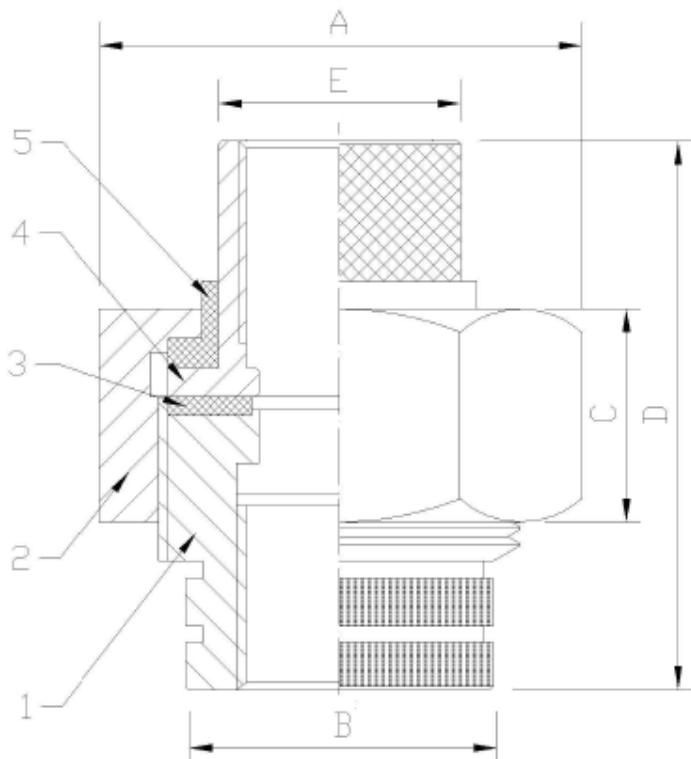

MATERIAL SPECIFICATIONS

No.	Part	Material
1	IPS Connection	Zinc Coated Cast Steel
2	Nut	Zinc Coated Cast Steel
3	Gasket	EPDM
4	IPS Connection	Zinc Coated Cast Steel
5	Insert	Nylon

*This product complies with 0.25% weighted average lead content on wetted surfaces in accordance with the Safe Drinking Water Act (SDWA) / Federal Public Law No. 111-380.



CALIFORNIA 5593 Fresca Dr., La Palma CA 90623
TEXAS 1150 Silber Rd., Houston TX 77055
ILLINOIS 278 Windy Point Dr., Glendale Heights, IL 60139
NEW YORK PO Box 27, Rt.22, Brewster NY 10509
 WEB: www.matco-norca.com

• Phone: 866-532-8306 • Fax: 866-532-8307
 • Phone: 800-935-5456 • Fax: 713-680-2999
 • Phone: 844-412-5068 • Fax: 800-640-2252
 • Phone: 800-431-2082 • Fax: 845-278-9056
 EMAIL: mail@matco-norca.com

LF Dielectric Union - Female X SWT • Spec Sheet



FEATURES & BENEFITS

- Lead Free Brass*
- 250 PSI @ 80°F; 125 PSI @ 180°F
- Sizes 2-1/2" - 3"

DIMENSIONS

Part #	Size	A	B
DUN-0909LF	2-1/2"	3.54	6.11
DUN-1010LF	3"	3.74	6.70

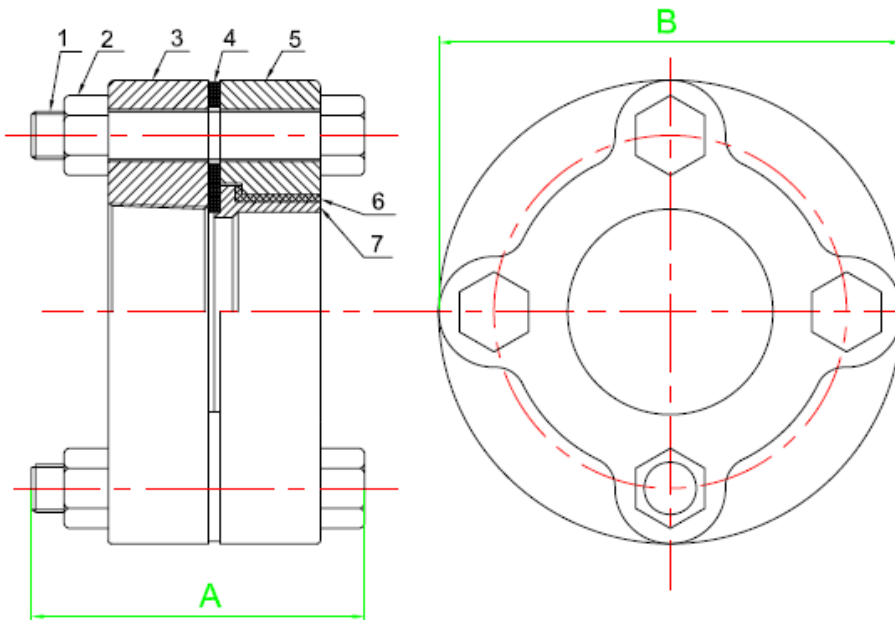

MATERIAL SPECIFICATIONS

No.	Part	Material
1	Bolts	Zinc Coated Steel
2	Nuts	Zinc Coated Steel
3	Flange	Cast Iron W/ Galvanized
4	Gasket	EPDM
5	Flange	Cast Iron W/ Galvanized
6	Insulator	Nylon
7	Solder Connection	Lead Free Brass

*This product complies with 0.25% weighted average lead content on wetted surfaces in accordance with the Safe Drinking Water Act (SDWA) / Federal Public Law No. 111-380.



CALIFORNIA 5593 Fresca Dr., La Palma CA 90623
TEXAS 1150 Silber Rd., Houston TX 77055
ILLINOIS 278 Windy Point Dr., Glendale Heights, IL 60139
NEW YORK PO Box 27, Rt.22, Brewster NY 10509
 WEB: www.matco-norca.com

• Phone: 866-532-8306 • Fax: 866-532-8307
 • Phone: 800-935-5456 • Fax: 713-680-2999
 • Phone: 844-412-5068 • Fax: 800-640-2252
 • Phone: 800-431-2082 • Fax: 845-278-9056
 EMAIL: mail@matco-norca.com

LF Dielectric Union - Female X SWT • Spec Sheet



FEATURES & BENEFITS

- Lead Free Brass*
- 250 PSI @ 80°F; 125 PSI @ 180°F
- Sizes 4"

DIMENSIONS

Part #	Size	A	B
DUN-1111LF	4"	9.14	4.53

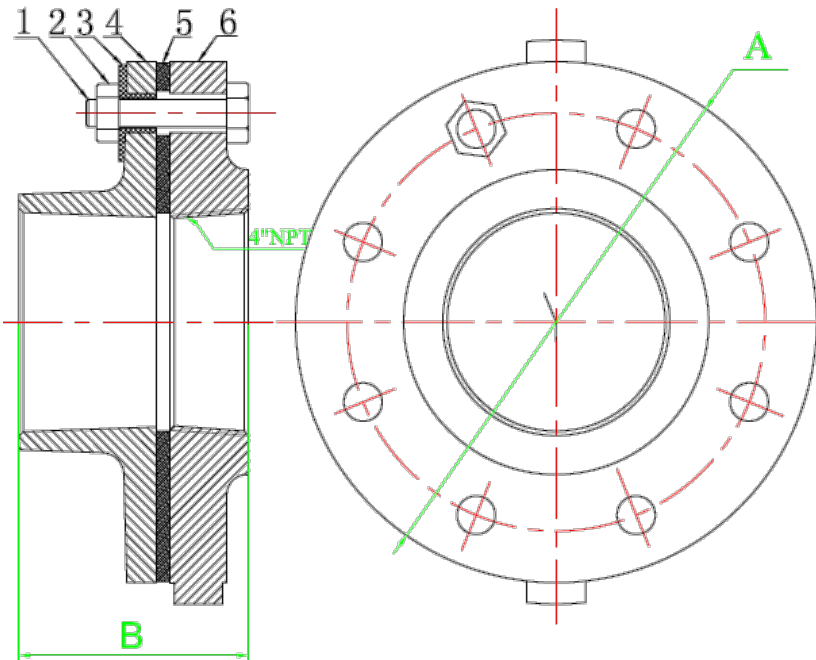

MATERIAL SPECIFICATIONS

No.	Part	Material
1	Bolts	Zinc Coated Steel
2	Nuts	Zinc Coated Steel
3	Plastic Gasket	EPDM
4	Flange	Brass
5	Rubber Washer	Nylon
6	Flange	Zinc Coated Cast Iron

*This product complies with 0.25% weighted average lead content on wetted surfaces in accordance with the Safe Drinking Water Act (SDWA) / Federal Public Law No. 111-380.



CALIFORNIA 5593 Fresca Dr., La Palma CA 90623
TEXAS 1150 Silber Rd., Houston TX 77055
ILLINOIS 278 Windy Point Dr., Glendale Heights, IL 60139
NEW YORK PO Box 27, Rt.22, Brewster NY 10509
 WEB: www.matco-norca.com

• Phone: 866-532-8306 • Fax: 866-532-8307
 • Phone: 800-935-5456 • Fax: 713-680-2999
 • Phone: 844-412-5068 • Fax: 800-640-2252
 • Phone: 800-431-2082 • Fax: 845-278-9056
 EMAIL: mail@matco-norca.com

LF Dielectric Union - Female X BPT • Spec Sheet



FEATURES & BENEFITS

- Lead Free Brass*
- 250 PSI @ 80°F; 125 PSI @ 180°F
- Sizes 2-1/2" - 4"

DIMENSIONS

Part #	Size	A	B
DUN-GA09LF	2-1/2"	2.36	7.01
DUN-GA10LF	3"	2.52	7.53
DUN-GA11LF	4"	2.76	9.14

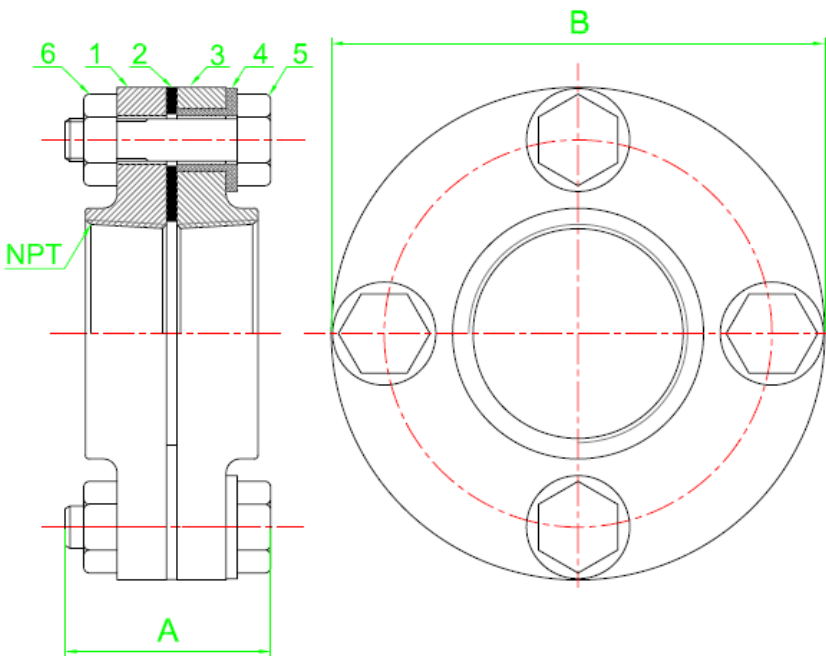

MATERIAL SPECIFICATIONS

No.	Part	Material
1	Flange	Cast Iron W/ Galvanized
2	Gasket	EPDM
3	Flange	Lead Free Bronze
4	Insulator	Nylon
5	Bolts	Zinc Coated Steel
6	Nuts	Zinc Coated Steel

*This product complies with 0.25% weighted average lead content on wetted surfaces in accordance with the Safe Drinking Water Act (SDWA) / Federal Public Law No. 111-380.



CALIFORNIA 5593 Fresca Dr., La Palma CA 90623
TEXAS 1150 Silber Rd., Houston TX 77055
ILLINOIS 278 Windy Point Dr., Glendale Heights, IL 60139
NEW YORK PO Box 27, Rt.22, Brewster NY 10509
 WEB: www.matco-norca.com

• Phone: 866-532-8306 • Fax: 866-532-8307
 • Phone: 800-935-5456 • Fax: 713-680-2999
 • Phone: 844-412-5068 • Fax: 800-640-2252
 • Phone: 800-431-2082 • Fax: 845-278-9056
 EMAIL: mail@matco-norca.com