

# AHV Hot Water Radiator Valve • Spec Sheet



## FEATURES & BENEFITS

- Hot Water Radiator Angle Valve
- Brass Body
- Heavy Pattern
- With Nut & Tailpiece
- 60 PSI Non-Shock Hot Water
- 15 PSI Steam
- FIP x Male Union 1/2" – 1-1/4"
- Solder x Male Union 1/2" - 3/4"
- Sizes 1/2" – 1-1/4"

## DIMENSIONS

Part #	Size	D	H	L
AHV-0500	1/2" FIP	2.30	2.36	2.21
AHV-0750	3/4" FIP	2.30	2.40	2.64
AHV-1000	1" FIP	2.30	3.05	2.84
AHV-1250	1-1/4" FIP	2.30	3.33	3.19
AHV-0500C	1/2" Solder	2.30	2.36	2.21
AHV-0750C	3/4" Solder	2.30	2.40	2.64

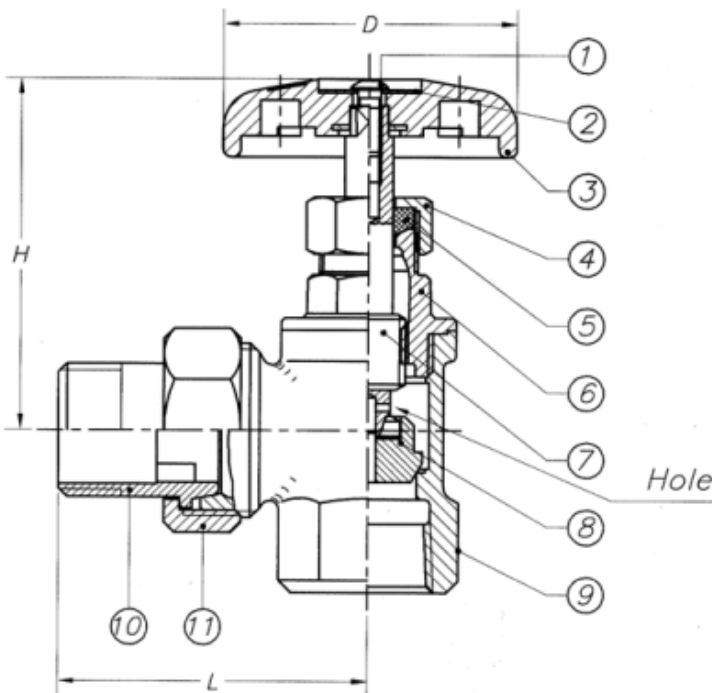

## MATERIAL SPECIFICATIONS

No.	Part	Material
1	Handle Bolt	Hot Rolled SAE 1010R
2	Name Plate	Aluminum A1100
3	Handwheel	Phenolic
4	Packing Nut	Brass B16 C36000
5	Gland Packing	PTFE
6	Bonnet	Brass B584 C85710
7	Stem	Brass B584 C85710
8	Disc	Brass B584 C85710
9	Body	Brass B584 C85710
10	Nipple	Brass B124 C37700
11	Nipple Nut	Brass B124 C37700

\*Hole drilled in seat for hot water use.

