

58LGAN Gas Valve • Spec Sheet



FEATURES & BENEFITS

- Economy Valve
- Gas Ball Valve
- 600 WOG
- 1/2 PSIG and 5 G
- Operating Range -4°F to 149°F
- CSA & UL Approved
- Lockable by Reversing Handle Orientation
- Available in Lever
- Sizes - FIP x FIP 1/2" - 1"

DIMENSIONS

Part #	Size	L	H	A
58LGA3N	1/2"	2.17	1.28	1.42
58LGA4N	3/4"	2.34	1.28	1.54
58LGA5N	1"	2.88	1.28	1.69

MATERIAL SPECIFICATIONS

No.	Part	Material
1	Body	Brass C37700
2	Sealing Washer	PTFE
3	Chrome Plated Ball	Brass C3700
4	O-Ring*	NBR
5	Packing Nut	Brass C3700
6	Stem	Brass C3700
7	Handle Nut	Chrome Plated Steel
8	Ball Packing	PTFE
9	Handle	Aluminum Alloy
10	Cap	Brass C3700

*58LGA5N Does Not Contain This Part

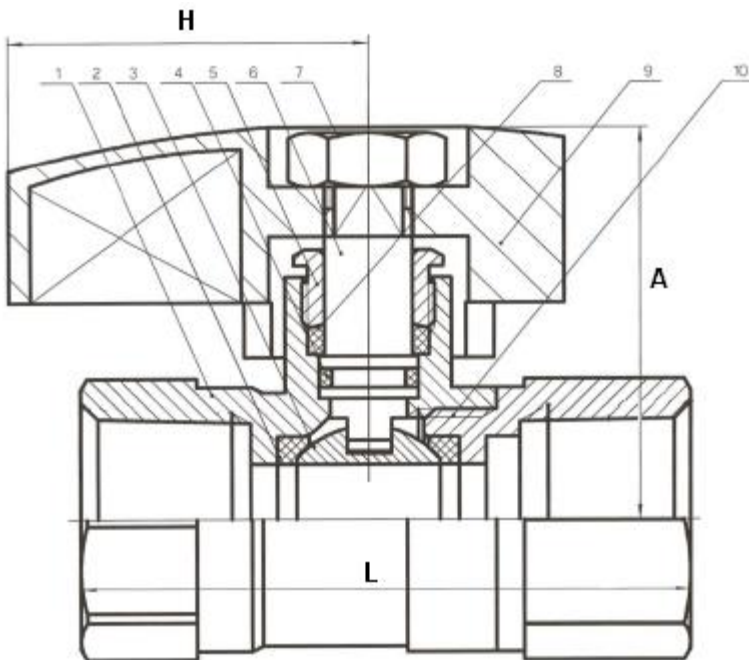

CALIFORNIA 5595 Fresca Dr., La Palma CA 90623
TEXAS 1150 Silber Rd., Houston TX 77055
ILLINOIS 278 Windy Point Dr., Glendale Heights, IL 60139
GEORGIA 113 Industrial Blvd., Americus, Georgia 31709
NEW YORK PO Box 27, Rt.22, Brewster NY 10509
 WEB: www.matco-norca.com

• Phone: 866-532-8306 • Fax: 866-532-8307
 • Phone: 800-935-5456 • Fax: 713-680-2999
 • Phone: 844-412-5068 • Fax: 800-640-2252
 • Phone: 800-433-7526 • Fax: 800-533-5134
 • Phone: 800-431-2082 • Fax: 845-278-9056
 EMAIL: mail@matco-norca.com