

# 225RT DI Push-On x Push-On Valve • Spec Sheet

## FEATURES & BENEFITS

- Ductile Iron Gate Valve
- Push-On x Push-On (C900/DI Pipe)
- Resilient Wedge
- Non Rising Stem
- AWWA C515-15
- 300 PSI
- UL Listed / FM Approved
- AWWA C550 Epoxy
- NSF-61 / NSF-372 verified by UL Water Quality
- Can Be Fitted With Post Indicator Plate

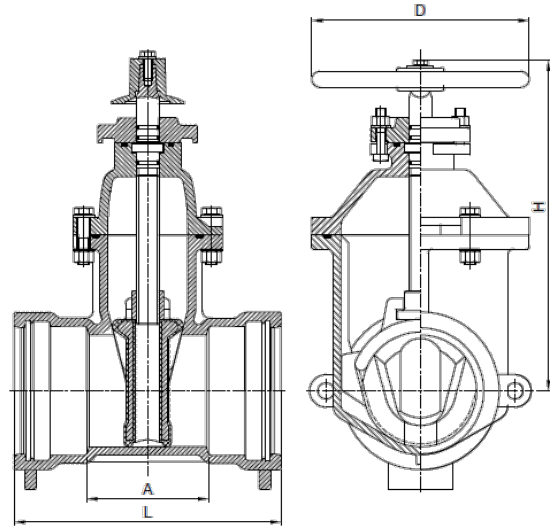

## DIMENSIONS

Part #	Size	L	H	D	A
225RT11	4"	14	16	10.0	6.0
225RT13	6"	15	19	12.0	7.0
225RT14	8"	18	23	14.0	9.0
225RT15	10"	18.5	26	17.5	9.5
225RT16	12"	18.5	31	17.5	8.5

## MATERIAL SPECIFICATIONS

No.	Part	Material	ASTM Spec.
1	Body	Ductile Iron	A536-65-45-12
2	Wedge	Ductile Iron EPDM Encapsulated	A536-65-45-12
3	Stem Nut	Bronze	ASTM C95200
4	Stem	Stainless Steel	ANSI 304
5	Gasket	Rubber	EPDM
6	Bolt	Stainless Steel	SS304
7	Bonnet	Ductile Iron	A536-65-45-12
8	O-Ring	Rubber	NBR
9	Thrust Collar	Bronze	ASTM C95200
10	O-Ring	Rubber	NBR
11	Gland	Ductile Iron	A536-65-45-12
12	O-Rings	Rubber	NBR
13	Dust Ring	Rubber	NBR
14	Operating Nut (Optional)	Ductile Iron	A536-65-45-12
15	Bolts	Stainless Steel	SS304
16	Washer	Stainless Steel	SS304
17	Handwheel (Optional)	Ductile Iron	A536-65-45-12
18	Bolts	Stainless Steel	SS304



**CALIFORNIA** 5595 Fresca Dr., La Palma CA 90623  
**TEXAS** 1150 Silber Rd., Houston TX 77055  
**ILLINOIS** 278 Windy Point Dr., Glendale Heights, IL 60139  
**GEORGIA** 113 Industrial Blvd., Americus, Georgia 31709  
**NEW YORK** PO Box 27, Rt.22, Brewster NY 10509  
 WEB: [www.matco-norca.com](http://www.matco-norca.com)

• Phone: 866-532-8306 • Fax: 866-532-8307  
 • Phone: 800-935-5456 • Fax: 713-680-2999  
 • Phone: 844-412-5068 • Fax: 800-640-2252  
 • Phone: 800-433-7526 • Fax: 800-533-5134  
 • Phone: 800-431-2082 • Fax: 845-278-9056  
 EMAIL: [mail@matco-norca.com](mailto:mail@matco-norca.com)