

# 204LSLF Long Shank Boiler Drain • Spec Sheet

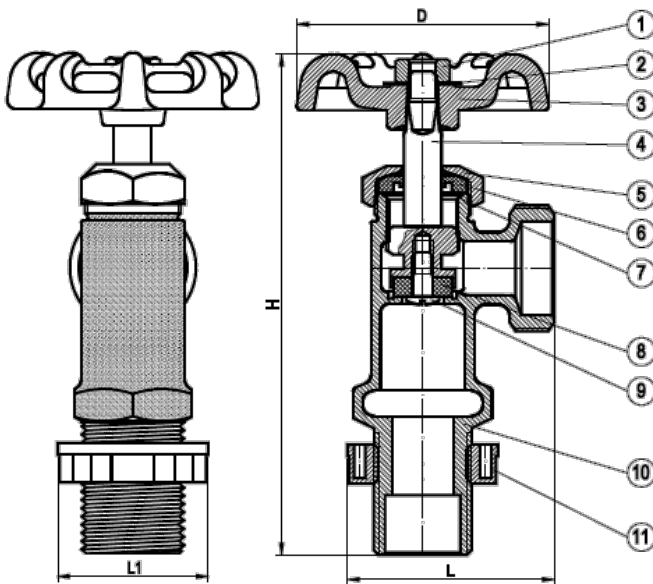

## FEATURES & BENEFITS

- Lead Free Brass\*
- ISO-9002
- 125 WOG
- Boiler Drain-Less Stuffing Box
- cUPC Approved
- Shank Lock Nut
- 1/2" MIP x 1/2" Solder Inlet



## DIMENSIONS

Part #	H	L	L1	D
204LS3LF	4.20	1.73	1.26	2.11

## MATERIAL SPECIFICATIONS

No.	Part	Material
1	Wheel Nut	Hot Rolled Wire Rods
2	Name Plate	Aluminum 1070
3	Hand Wheel	Rod-Carbon Steel SAE 1006
4	Stem	Brass C46400
5	Bonnet	Brass B124 C37700
6	Packing	SE-719F / SN-719F
7	Washer	Stainless Steel 304
8	Seat Packing	SE-719F / SN-719F
9	Seat Screw	JIS H3260 – C2600W
10	Body	Brass C46400
11	Lock Nut	POM M90 Polyacetal

\* These product complies with 0.25% weighted average lead content on wetted surfaces in accordance with Safe Water Drinking Act (SDWA) / Federal Public Law No. 111-380.

