

140F Cast Iron Y Strainer • Spec Sheet



APPLICATION: Low Pressure Steam, Water, Air, and Non-Corrosive Gas or Oil.

CHART FOR SCREEN

Size	Screen Opening	Holes Per Square Inch	Standard Material
2" - 5"	1/16" Perf.	144	Stainless Steel
6" - 12"	1/8" Perf.	32	Stainless Steel

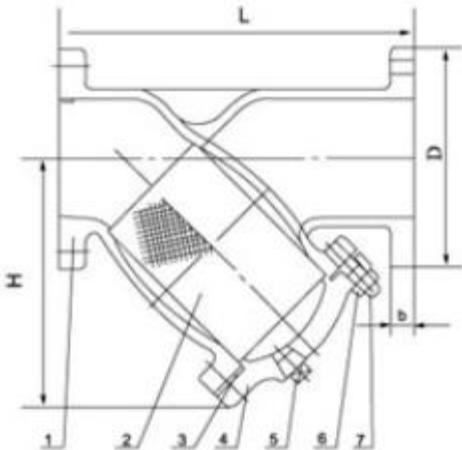

FEATURES & BENEFITS

- Y Strainer - Flanged Ends
- Class 125 Flanged Ends
- 200 WOG - 125 WSP
- Maximum Temperature 450° F
- Bolted Cover With Blow Out Port & Plug
- Standard Screen is Perforated 304 S.S
- Conforms With ANSI B16.1.
- ISO-9002
- Sizes 2" - 12"

DIMENSIONS

Part #	Size	L	D	b	H
140F08	2"	8.88	6.00	0.62	5.67
140F09	2-1/2"	10.75	7.00	0.69	6.93
140F10	3"	11.50	7.50	0.75	7.68
140F11	4"	13.88	9.00	0.94	9.69
140F12	5"	16.38	10.00	0.94	11.81
140F13	6"	18.50	11.00	1.00	12.60
140F14	8"	21.38	13.50	1.12	15.63
140F15	10"	26.00	16.00	1.19	19.02
140F16	12"	30.00	19.00	1.25	22.05

CHART FOR PLUG IN CAP

Strainer Size	Plug Size	Strainer Size	Plug Size
2"	1/2" NPT	4"	1-1/2" NPT
2-1/2" - 3"	1" NPT	5" - 12"	2" NPT

MATERIAL SPECIFICATIONS

No.	Part	Material	ASTM Designation
1	Body	Cast Iron	ASTM A126 B
2	Screen	Stainless Steel	304
3	Gasket	Graphite Steel	
4	Cover	Cast Iron	ASTM A126 B
5	Plug	Malleable Iron	
6	Nut	Steel	ASTM A307-B
7	Stud	Steel	ASTM A307-B

