

120SS Cast Iron Check Valve • Spec Sheet



FEATURES & BENEFITS

- Threaded Ends
- 200 CWP
- Resilient Seat
- Epoxy Coating
- Bolted Cover
- Outside Lever & Spring
- Conforms to MSS-SP-71
- Threaded Ends Conform to ANSI / ASME B1.20.1
- Sizes 3" and 4" Only

DIMENSIONS

Part #	Size (Ød)	L	A	B	H	H1	Approx Weight
120SS10	3"	9"	5"	4-5/16"	4-3/4"	2-1/2"	27.5
120SS11	4"	10-1/2"	7-1/16"	6-1/16"	5-3/4"	3-17/32"	54.5

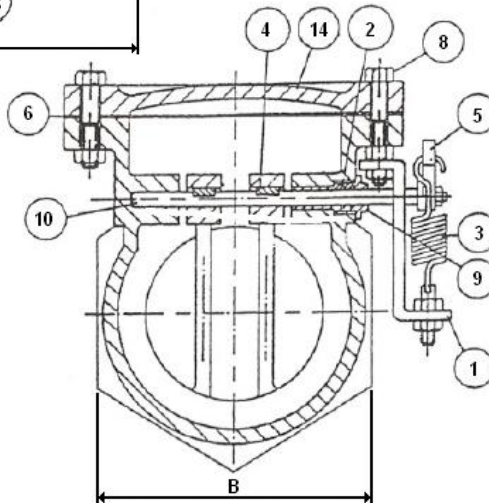
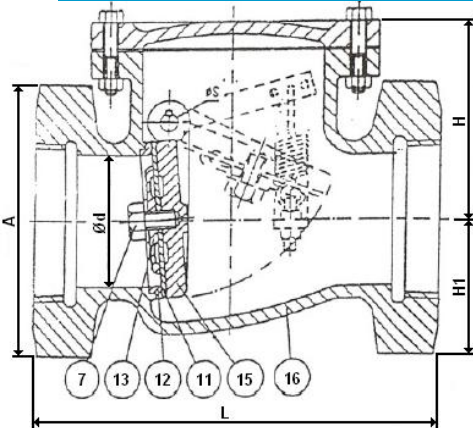

MATERIAL SPECIFICATIONS

No	Part	Material
1	Arm B	Steel - A36
2	O - Ring	Buna N - D 2000 AA 7008
3	Spring	Steel
4	Key	Stainless Steel - A 276 Type 304
5	Arm A	Steel - A36
6	Cover Gasket	Buna N - D 2000 AA 7008
7	Seat Holder Bolt	Stainless Steel - A 276 Type 304
8	Cover Bolt & Nut	Steel - A 307 Grade B
9	Seat Nut	Brass - B 36
10	Hinge Pin	Stainless Steel - A 276 Type 304
11	Disc Seat Ring	Buna N - D 2000 AA 7008
12	Body Seat Ring	Bronze - B 62
13	Seat Holder	Cast Iron - A 126 Class B
14	Cover	Cast Iron - A 126 Class B
15	Disc	Cast Iron - A 126 Class B
16	Body	Cast Iron - A 126 Class B

