

# 105S Threaded Cast Iron Gate Valve • Spec Sheet



## FEATURES & BENEFITS

- ISO-9002
- Gate Valve-Threaded Ends
- 200 WOG-125 WSP
- Iron Body, Bronze Mounted (IBBM)
- Bolted Bonnet
- Outside Stem & Yoke Rising Stem
- Solid Wedge
- Conforms to MSS-SP70
- Threaded Ends Conform to ANSI B1.20.1
- Bituminous Coating
- Sizes 2" - 6"

## DIMENSIONS

Size d $\phi$	Part #	L	A	B	W $\phi$	H	H1	S $\phi$	WT. LBS.
2"	105S08	5.00	3.63	3.13	6.31	11.50	1.81	0.75	25.10
2-1/2"	105S09	5.50	4.31	3.75	7.50	12.50	2.16	0.75	25.50
3"	105S10	5.94	5.00	4.31	7.69	14.94	2.50	0.75	38.30
4"	105S11	7.50	7.06	6.06	9.88	17.69	3.53	0.88	66.00
6"	105S13	9.06	9.44	8.19	11.81	22.25	4.72	1.00	132.90

## APPLICATIONS:

Low Pressure Steam, Water, Air  
& Non-Corrosive Gas or Oil

## MATERIAL SPECIFICATIONS

No.	Part	Material	ASTM Designation
1	Body	Cast Iron	A 126 Class B
2	Bonnet	Cast Iron	A 126 Class B
3	Yoke	Cast Iron	A 126 Class B
4	Disc Seat Ring	Bronze	B 62
5	Body Seat Ring	Bronze	B 62
6	Disc	Cast Iron	A 126 Class B
7	Hand Wheel Nut	Steel	A 307 Grade B
8	Stem	Brass	B 124
9	Hand Wheel	Cast Iron	A 126 Class B
10	Bonnet Gasket	Non Asbestos Sheet	F 104P 1141 A
11	Bonnet Body Bolt	Steel	A 307 Grade B
12	Bonnet Body Nut	Steel	A 307 Grade B
13	Packing	Carbonized Fiber	D 4102
14	Hand Wheel Washer	Bronze	B 62
15	Yoke Sleeve	Bronze	B 62
16	Gland	Cast Iron	A 126 Class B
17	Gland Bolt	Steel	A 307 Grade B
18	Gland Nut	Steel	A 307 Grade B
19	Yoke Bonnet Bolt	Steel	A 307 Grade B
20	Yoke Bonnet Nut	Steel	A 307 Grade B

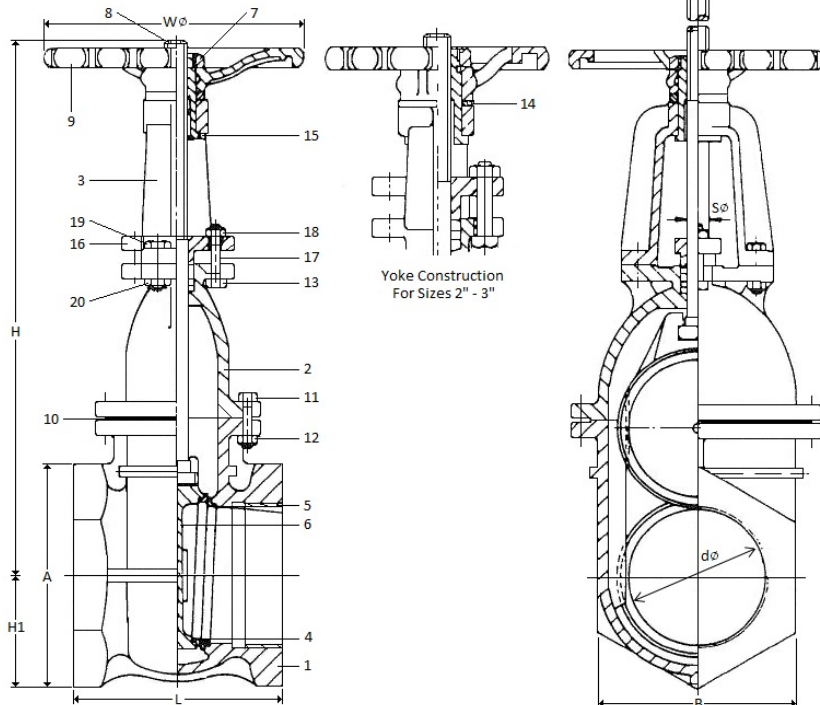

**MATCO**  
**NORCA**