

225IPAB & 225WMIP Data & Installation Sheet

GENERAL DESCRIPTION

Vertical indicator posts (Ref. Figure A) are designed to operate non-rising stem gate valves, which are used to control an underground water supply to automatic sprinkler, water spray deluge, foam-water deluge, or standpipe fire protection systems. They permit operation of underground valves while providing an above ground visual indication as to whether the valves are open or shut, in addition to a means for locking the valves in a particular position. Indicator posts provide for valve operation from outside of the protected property and, therefore, the opportunity for more prompt valve operation in an emergency situation.

Model 225IPAB indicator posts feature a telescoping stem that can be adjusted to its final position without field cutting of the stem. The telescoping stem also permits: easier setting of the “OPEN” and “SHUT” target plates (before the post is extended to its final position); easier adjustment of the post length during the initial installation; and, ready re-adjustment of the post length, if there is a modification in the location of the final grade.

Indicator posts will accommodate 4” – 12” post indicator valves (PIV) requiring 14 to 43 turns to open and that are listed or approved for fire protection system service. Indicator posts are provided “Standard Order” for use with left hand opening valves; however, they may be “Special Ordered” for use with right hand opening valves or converted in the field for use with a right hand opening valve by changing the left hand opening post head to a right hand opening post head. Indicator posts are designed to withstand up to 900 ft. - lbs. of operating torque.

Indicator Posts accept direct attachment of a 1/2” NPT mounting electric supervisory switching device which can be used by proprietary and central stations to monitor the open position of the indicator post. Detailed information on attaching a UL/FM approved supervisory control valve switch (supplied by customer) is given in the technical data section.

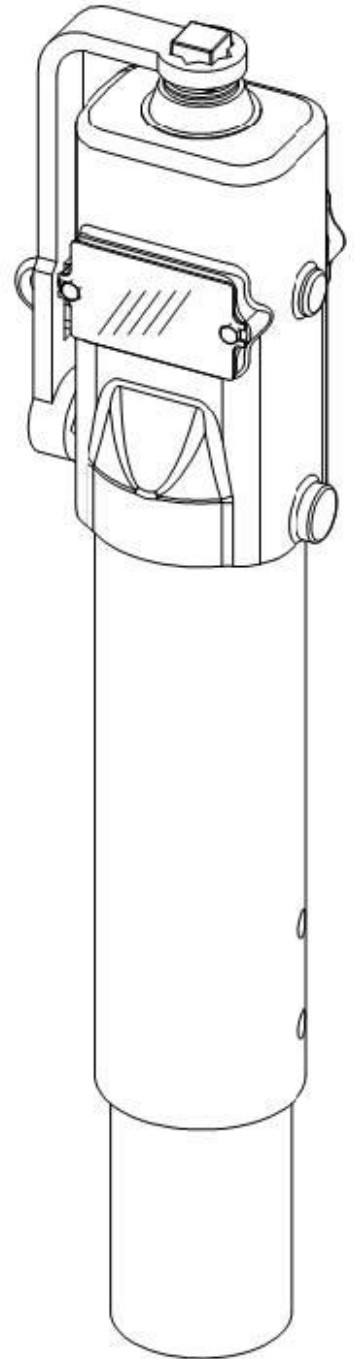

Fig. A 225IPAB

225IPAB & 225WMIP Data & Installation Sheet

TECHNICAL DATA

The 225IPAB indicator post bolts directly onto the stuffing box flange of 4" – 12" post indicator valves (PIV) employing 2" operating nuts. The bell attaches to a PIV mounting flange having four bolt holes spaced at 90° on a 10-1/2" diameter bolt circle. The bell has 3/4" clearance holes for the mounting bolts.

The 225IPAB indicator post has a threaded sleeve which can readily accommodate field positioning of the "OPEN" and "SHUT" targets for 4" – 12" PIVs requiring 14 to 43 turns to open.

The 225IPAB indicator post (Ref. Figure B) is intended for use in order lengths A & B only (Ref. TABLE 1). Each "Order Length" provides for adjustment of dimension "L". The post head can be adjusted relative to the lower barrel by using the two set screws located at the base of the upper barrel.

TABLE 1 Dimension L

ORDER LENGTH	MIN	MAX
A	18.25"	39.50"
B	36.00"	60.50"

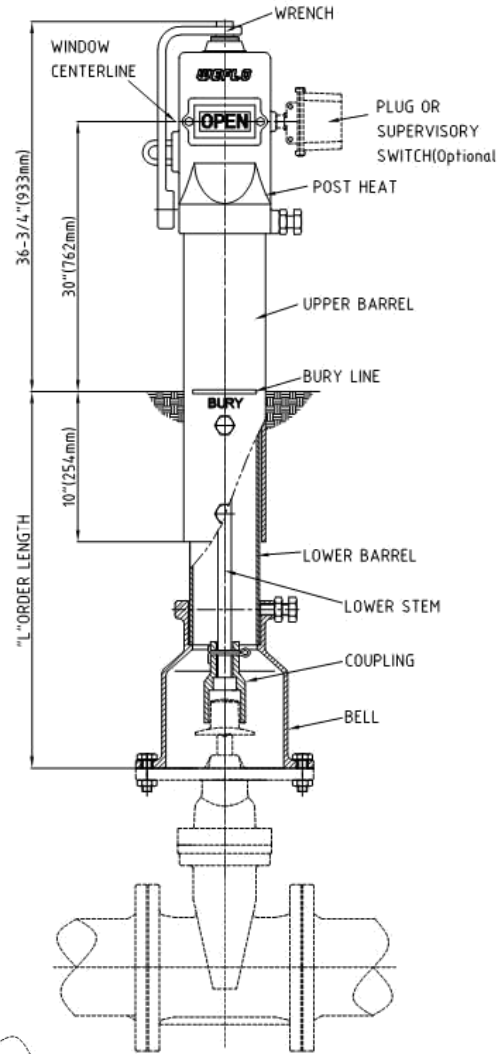

Fig. B 225IPAB

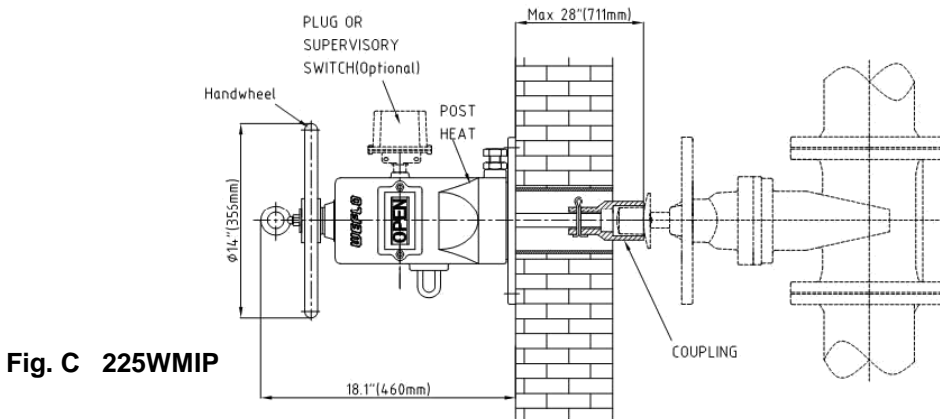

Fig. C 225WMIP

225IPAB & 225WMIP Data & Installation Sheet

INSTALLATION INSTRUCTIONS

Post Targets must be positioned for use with the appropriate number of turns to open the post indicator valve. Improper positioning of the targets can result in an erroneous indication of the open or shut position of the valve.

NOTE: The targets for the 225IPAB or 225WMIP indicator post have been factory set for use with a 6" gate valve.

Installing the Post

1. Check the valve for the total number of turns necessary to OPEN / CLOSE;
2. Completely close the valve;
3. Loosen the POST HEAD bolts (9,10), and lift off the POST HEAD/UPPER STEM assembly;

4. Remove the wrench (25) or hand wheel (21), pry off the weather cap (2), remove the retaining ring (3), and then lift the post head clear of the upper stem assembly.

5. Position the targets per Figure F, set "SHUT" target first, set "OPEN" target top surface of threaded with valve size, check the dimensional "H". "H" IN INCHES=NUMBER OF TURNS TO OPEN VALVE / 14

6. Replace retaining ring (3), weather cap (2), and put POST HEAD/UPPER STEM assembly install on the UPPER BARREL. Tighten the POST HEAD

bolt(9,10)with a torque of 40 to 60 ft.lbs.

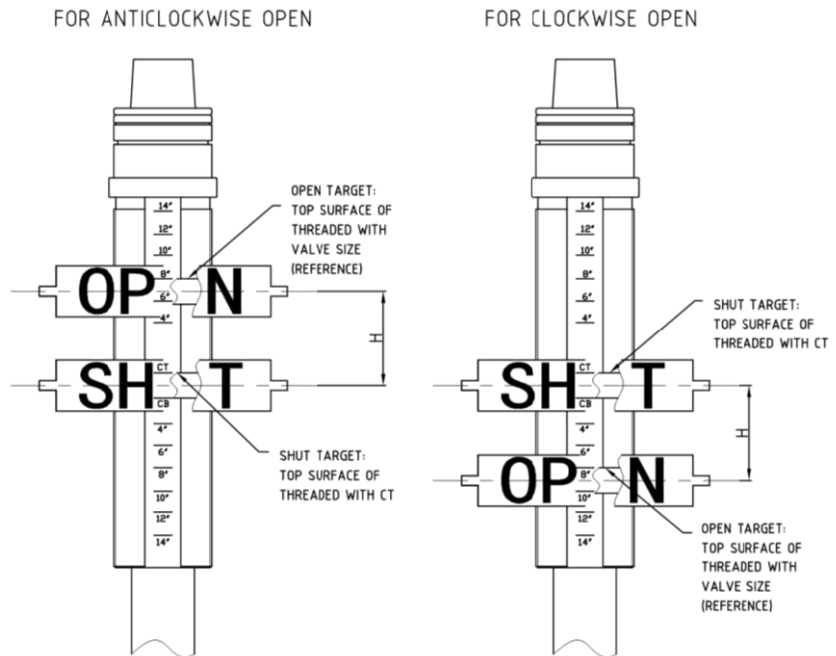

7. Using the wrench (25) or hand wheel (21), open and close the valve and check to see that the "SHUT" and "OPEN" targets are clearly in view in the windows, at their respective positions, and that there is no feeling of binding of the upper or lower stem assemblies. It is recommended that the turns to open/close be counted and compared to the valve manufacturer's specification, in order to verify full valve opening.

NOTE: If there is any indication of binding of the internal operating parts, the vertical alignment of the indicator post must be corrected.

225IPAB & 225WMIP Data & Installation Sheet

If the target plates are not properly in view, completely close the PIV and then repeat Steps 5. 8. Loosen the two bolts (13) at the base of the upper barrel (11) and then slide the post head up until the bury line of the post head coincides with the planned finished grade. Tighten the two bolts (13) with a torque of 40 to 60 ft.lbs. When properly installed, the centerline of the target windows will be 30 inches above the finish grade.

CARE AND MAINTENANCE

Model 225 IPAB indicator posts do not require any regularly scheduled maintenance. It is recommended that indicator posts are used to ensure that fire protection water control valves are locked in the fully open position. It is recommended that a once a month visual inspection procedure be followed, with the following items being checked:

1. The post head, upper barrel, and windows have not been damaged.
2. The targets indicate that the valve is open.
3. The wrench is in place on the indicator post, and it is properly locked in the "open" position.

In addition, on a quarterly basis, the indicator post should be closed two turns and then reopened tight to verify that the PIV is in the full open position and properly engages with the post and, that the supervisory switch contacts (if applicable) properly change position. Any damaged parts must be immediately replaced. The indicator post should also be physically tried to be sure that the valve is in the fully-open position, if there are any damaged parts, sign of tampering, or the position of the valve is questionable.

NOTE: Before closing a fire protection system main valve for maintenance work on either the indicator post or fire protection systems which it controls, permission to shut down the affected fire protection systems must first be obtained from the proper authorities and all personnel who may be affected by this decision must be notified.

It is recommended that fire protection systems be inspected by a qualified inspection service.

