

Installation Manual

567200J

RE/REX-Series

*Omnivore® Grinder Pump Retrofit Unit
Fully assembled replacement package*

Core replacement for:

E/One® GP200 and GP2000

LSG202-RE

2 hp, 208/230V, 1-phase, Automatic

LSGX202-RE

2 hp, 208–230V, 1-phase, Automatic

E/One® Extreme D-Series

LSG202-REX

2 hp, 208/230V, 1-phase, Automatic

LSGX202-REX

2 hp, 208–230V, 1-phase, Automatic



E/One® is a registered trademark of Environment One Corporation



For pressure sewer applications, verify a Redundant Check Valve Assembly (curb stop and check valve) is installed between the pump discharge and the street main, as close to the public right-of-way as possible, on all installations to protect from system pressures.



NOTICE

Installer: Manual must remain with owner/operator.

Prior to installation, record information from pump nameplate for future reference:

7000 Apple Tree Avenue
Bergen, NY 14416
ph: 1-800-543-2550
fax: 1-585-494-1839
www.LibertyPumps.com

Keep this manual handy for future reference.
For replacement manual, visit LibertyPumps.com,
or contact Liberty Pumps at 1-800-543-2550.
Retain dated sales receipt for warranty.

Model: _____

Serial: _____





Mfg Date: _____

Install Date: _____

Contents

Safety Precautions	2 EN
Model Specifications	4 EN
Inspection and Storage	4 EN
Pump Design	4 EN
Pressure Sewer Applications	4 EN
Pump Replacement	5 EN
Operation	6 EN
Maintenance and Troubleshooting	6 EN
Warranty	6 EN

Safety Guidelines

	This safety alert symbol is used in the manual and on the pump to alert of potential risk for serious injury or death.
	This safety alert symbol identifies risk of electric shock . It is accompanied with an instruction intended to minimize potential risk of electric shock.
	This safety alert symbol identifies risk of fire . It is accompanied with an instruction intended to minimize potential risk of fire.
	This safety alert symbol identifies risk of serious injury or death . It is accompanied with an instruction intended to minimize potential risk of injury or death.
⚠ DANGER	Warns of hazards which, if not avoided, will result in serious injury or death.
⚠ WARNING	Warns of hazards which, if not avoided, could result in serious injury or death.
⚠ CAUTION	Warns of hazards which, if not avoided, could result in minor or moderate injury.
NOTICE	Signals an important instruction related to the pump. Failure to follow these instructions could result in pump failure or property damage.

⚠ WARNING Read every supplied manual before using pump system. Follow all the safety instructions in manual(s) and on the pump. Failure to do so could result in serious injury or death.

Safety Precautions

⚠ WARNING **RISK OF ELECTRIC SHOCK**

- Accidental contact with electrically live parts, items, fluid, or water can cause serious injury or death.
- Always disconnect pump(s) from power source(s) before handling or making any adjustments to either the pump(s), the pump system, or the control panel.
- All installation and maintenance of pumps, controls, protection devices, and general wiring shall be done by qualified personnel.
- All electrical and safety practices shall be in accordance with the National Electrical Code[®], the Occupational Safety and Health Administration, or applicable local codes and ordinances.
- Do not remove cord and strain relief, and do not connect conduit to pump.
- Pump shall be properly grounded using its supplied grounding conductor. Do not bypass grounding wires or remove ground prong from attachment plugs. Failure to properly ground the pump system can cause all metal portions of the pump and its surroundings to become energized.
- Do not handle or unplug the pump with wet hands, when standing on damp surface, or in water unless wearing Personal Protective Equipment.
- Always wear dielectric rubber boots and other applicable Personal Protective Equipment (PPE) when water is on the floor and an energized pump system must be serviced, as submerged electrical connections can energize the water. Do not enter the water if the water level is higher than the PPE protection or if the PPE is not watertight.
- Do not lift or carry a pump or a float assembly by its power cord. This will damage the power cord, and could expose the electrically live wires inside the power cord.
- The electrical power supply shall be located within the length limitations of the pump power cord, and for below grade installations it shall be at least 4 ft (1.22 m) above floor level.
- Do not use this product in applications where human contact with the pumped fluid is common (such as swimming pools, fountains, marine areas, etc.).
- Protect the power and control cords from the environment. Unprotected power and control (switch) cords can allow water to wick through ends into pump or switch housings, causing surroundings to become energized.
- Single-phase 208/230V pumps shall only be operated without the float switch by using the circuit breaker or panel disconnect.
- Some products may have internal capacitors that could cause shock. Avoid contact with plug ends after removing from energy source.

⚠️ WARNING**RISK OF FIRE**

- Do not use an extension cord to power the product. Extension cords can overload both the product and extension cord supply wires. Overloaded wires will get very hot and can catch on fire.
- This product requires a separate, properly fused and grounded branch circuit, sized for the voltage and amperage requirements of the pump, as noted on the nameplate. Overloaded branch circuit wires will get very hot and can catch on fire. When used, electrical outlets shall be simplex of the appropriate rating.
- For cord replacement: power cord must be of the same length and type as originally installed on the Liberty Pumps product. Use of incorrect cord may lead to exceeding the electrical rating of the cord and could result in death, serious injury, or other significant failure.
- Do not use this product with or near flammable or explosive fluids such as gasoline, fuel oil, kerosene, etc. If rotating elements inside pump strike any foreign object, sparks may occur. Sparks could ignite flammable liquids.
- Sewage and effluent systems produce and may contain flammable and explosive gases. Prevent introduction of foreign objects into basin as sparks could ignite these gases. Exercise caution using tools and do not use electronic devices or have live, exposed electrical circuits in or around basins, open covers and vents.
- These pumps are not to be installed in locations classified as hazardous in accordance with the National Electric Code[®], ANSI/NFPA 70.

⚠️ WARNING**RISK OF SERIOUS INJURY OR DEATH**

- Energizing the control panel or breaker for the first time is potentially dangerous. Licensed electrical personnel should be present when the panel or breaker is energized for the first time. If faults caused by damage or poor installation practices have not been detected, serious damage, injury or death can result when power is applied.
- Do not modify the pump/pump system in any way. Modifications may affect seals, change the electrical loading of the pump, or damage the pump and its components.
- All pump/pump system installations shall be in compliance with all applicable Federal, State, and Local codes and ordinances.
- Do not allow children to play with the pump system.
- Do not allow any person who is unqualified to have contact with this pump system. Any person who is unaware of the dangers of this pump system, or has not read this manual, can easily be injured by the pump system.
- In 208/230V installations, one side of the line going to the pump is always "hot", whether the float switch is on or off. To avoid hazards, install a double pole disconnect near the pump installation.
- Vent basin in accordance with local code. Proper venting of sewer and effluent gases alleviates poisonous gas buildup and reduces the risk of explosion and fire from these flammable gases.

- Wear adequate Personal Protective Equipment when working on pumps or piping that have been exposed to wastewater. Sump and sewage pumps often handle materials that can transmit illness or disease upon contact with skin and other tissues.
- Do not enter a pump basin after it has been used. Sewage and effluent can emit several gases that are poisonous.
- Do not remove any tags or labels from the pump or its cord.
- Keep clear of suction and discharge openings. To prevent injury, never insert fingers into pump while it is connected to a power source.
- Do not use this product with flammable, explosive, or corrosive fluids. Do not use in a flammable and/or explosive atmosphere as serious injury or death could result.
- This product contains chemicals known to the State of California to cause cancer and birth defects or other reproductive harm. www.p65warnings.ca.gov.
- A grinder pump contains metal parts that rotate at high speeds. Be careful around pump base while power is connected. Make sure that the pump is either in the tank or clear from people and wires when in operation.
- Wear Personal Protective Equipment to protect hands as cutter blades have extremely sharp edges and present a serious cutting hazard.

⚠️ CAUTION

- ◆ This pump has been evaluated for use with water only, however use with human waste and toilet paper is permitted.

NOTICE

- ◆ For pressure sewer applications, verify a Redundant Check Valve Assembly (curb stop and check valve) is installed between the pump discharge and the street main, as close to the public right-of-way as possible, on all installations to protect from system pressures.
- ◆ Do not dispose of materials such as paint thinner or other chemicals down drains. Doing so could chemically attack and damage pump system components and cause product malfunction or failure.
- ◆ Do not use pumps with fluid over 140°F (60°C). Operating the pump in fluid above this temperature can overheat the pump, resulting in pump failure. Maximum continuous duty fluid temperature is 104°F (40°C).
- ◆ Do not use pump system with mud, sand, cement, hydrocarbons, grease, or chemicals. Pump and system components can be damaged from these items causing product malfunction or failure. Additionally, flooding can occur if these items jam the impeller or piping.
- ◆ Submersible Pump—do not run dry
- ◆ The Uniform Plumbing Code[®] states that sewage systems shall have an audio and visual alarm that signals a malfunction of the system, to reduce the potential for property damage.
- ◆ Do not position the pump float directly under the inlet from drain tile or in the direct path of any incoming water.
- ◆ Keep pump upright.

Model Specifications

For complete listing of models and their specifications, refer to <http://www.LibertyPumps.com/About/Engineering-Specs>. Pump nameplate provides a record of specific pump information.

Inspection and Storage

Initial Inspection

The pump should be immediately inspected for damage that may have occurred in shipment.

1. Visually check the pump and any spare parts for damage.
2. Check for damaged electrical wires, especially where they exit the motor housing.

Contact Liberty Pumps customer service to report any damage or shortage of parts.

Storage Before Use

⚠️ WARNING RISK OF ELECTRIC SHOCK

- Protect the power and control cords from the environment. Unprotected power and control (switch) cords can allow water to wick through ends into pump or switch housings, causing surroundings to become energized.

NOTICE

- ◆ At no time shall the pump be stored within an incomplete wet pit. The pump shall not be placed into the pit until it can be fully operational.
- ◆ Do not allow the pump to freeze.

LSG/LSGX-Series Omnivore grinder pumps are shipped from the factory ready for installation and use. The pump should be held in storage if the pump station is not complete.

If storage is necessary, the pump should remain in its shipping container. It should be stored in a warehouse or storage shed that has a clean, dry temperature-stable environment where the pump and its container are covered to protect it from water, dirt, vibration, etc. The cord ends must be protected against moisture.

Uninstalled pumps that are idle for greater than three months should have cutters and impellers manually rotated once a month to lubricate the seals.

Installed pumps that are idle for greater than one month should have impellers and cutters manually operated through the breaker panel once a month to lubricate the seals.

Pumps that are idle in a wet basin must be removed.

Pump Design

LSG/LSGX-Series grinder pumps are designed for continuous underwater operation. The motor and pump form a close coupled, watertight unit. The induction motor is insulated against heat and moisture in accordance with Class B 265°F (130°C) regulations.

A thermal overload protector is embedded in the stator windings. This is connected in series and wired to shut down the pump if overheating occurs. The overload switch resets automatically when the motor cools.

The motor is protected against damage from water entry by two seals. The lower seal is a Viton lip seal and the upper seal is a graphite impregnated silicon carbide hard face seal.

The impeller and volute are designed for efficient flow characteristics and clog-free operation. The hardened cutters grind solids and fibrous matter into small particles that can be safely pumped through small diameter piping.

Pressure Sewer Applications

A redundant check valve assembly consisting of a curb stop and check valve must be installed between the pump discharge and the street main, as close to the public right-of-way as possible, on all pressure (force main) sewer installations to protect from system pressures. The curb stop valve is necessary to isolate the site from the pressure sewer while the check valve provides redundant protection against potentially detrimental backflow. All valves and fittings should be rated for at least 200 PSI service. See Liberty Pumps line of CSV-Series Curb Stop/Swing Check Valve Assemblies and CK-Series Connection Kit.

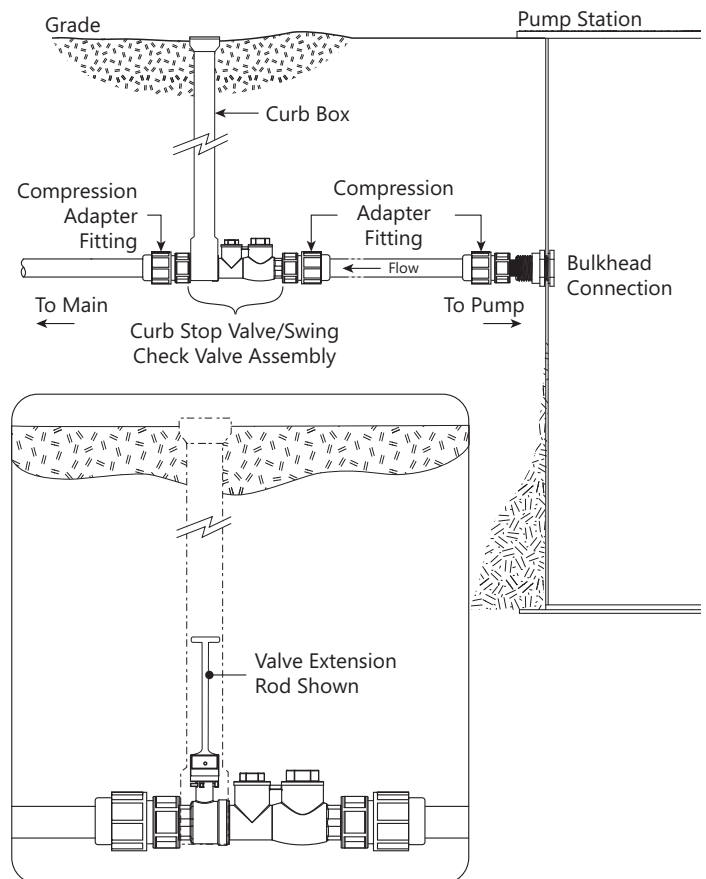

Pump Replacement

⚠️ WARNING **⚡ RISK OF ELECTRIC SHOCK**

- Always disconnect pump(s) from power source(s) before handling or making any adjustments to either the pump(s), the pump system, or the control panel.
- All installation and maintenance of pumps, controls, protection devices, and general wiring shall be done by qualified personnel.
- All electrical and safety practices shall be in accordance with the National Electrical Code®, the Occupational Safety and Health Administration, or applicable local codes and ordinances.

Liberty Pumps RE/REX models come equipped with 6-pin connectors that mate perfectly with existing control hardware. A Liberty Pumps Adapter Harness Kit is available to convert the RE-style connector to the REX-style connector. Kit #K001630 is sold separately.

The following is provided for additional troubleshooting, repair, or custom installation purposes.

Pin	Function	GP200/ GP2000 (square connector body)	Extreme D-Series (round connector body)	Liberty Pumps RE/REX
1	Manual Run	Red	Brown	Red
2	L1	Black	Red	Black
3	L2	White	Black	Yellow
4	Ground	Green	Green/Yellow	Brown
5	Alarm Feed	Orange	Yellow	Orange
6	Alarm Return	Blue	Blue	Blue

Old Pump Removal

1. Verify mains power is OFF.
2. Liberty Pumps recommends the use of a 30 amp circuit breaker to prevent nuisance tripping due to spikes in amp draw that may occur during heavy grinding events. Before making any changes, the amperage capacity of the branch circuit wiring and components must be verified and upgraded as required to conform to applicable codes and standards.
3. Locate the riser and remove basin lid from current unit.
4. If the basin is flooded, it should be pumped out with separate pump or vacuum. Discharge must be disposed of in accordance with local, state, and national codes.
5. Disconnect the electrical quick disconnect plug that is hanging in the basin, if applicable.
6. Remove bolts securing the current unit, if applicable.
7. Close valve on current unit.

8. Secure rope to hooks on cover. Lift the unit out of the basin.
9. Measure the distance from the cover to the base of the discharge elbow. Record this measurement to set the new unit to the same distance.

RE/REX Core Replacement

1. Apply gasket tape to the under or bottom side of the cover at the perimeter.
2. Adjust the discharge elbow's height by sliding it up or down in the discharge flange, matching that of the unit that was removed (**Old Pump Removal, Step 9**).

Do not fully tighten the three bolts on the discharge flange yet. The height of the discharge elbow might need to be slightly adjusted after the unit is assembled in the pit.

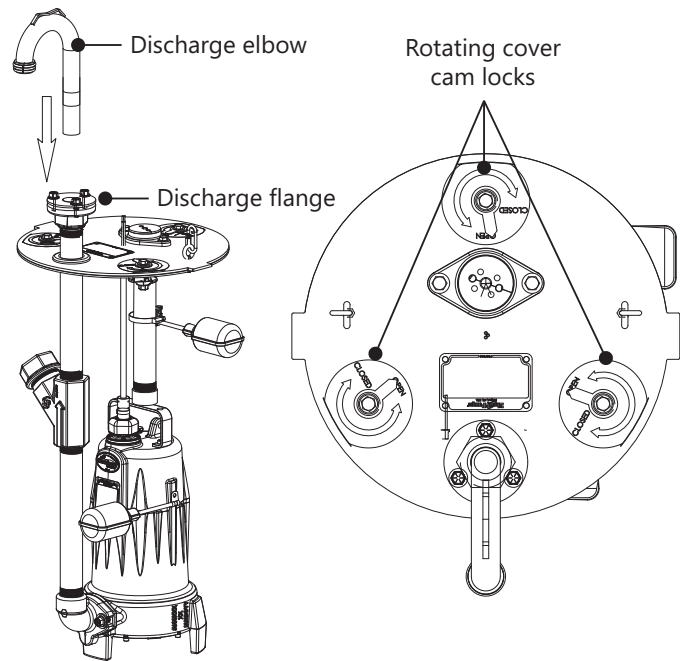

3. Located on the cover are three rotating cam locks used to secure the unit. Turn the cam locks to "OPEN" before lowering the unit into the pit.
4. Float switches must be positioned such that they will be free of any objects in the tank or tank walls. If adjustments are made to either one, make sure that floats will activate properly. *Specifically, confirm that the alarm float activates before hitting top cover.*
5. Lubricate the triple O-ring seal on the discharge elbow to ease installation of elbow into receiver.
6. Using the lifting rope, lower the grinder assembly into the basin. Align the cover tabs to the mating tank slots, and discharge elbow to the receiver/ball valve. The unit should come to rest squarely on the tank flange.
7. The three cam locks for the cover should now be secured by rotating the 3/8" hex bolts (9/16 socket) clockwise to the "CLOSED" position. The cam locks will wedge under the tank flange, securing the cover.
8. Press downward on the discharge elbow such that it seats fully in the ball valve's receiver. Tighten the three 3/8" bolts

(9/16 socket) on the discharge flange. This will compress the rubber ring and seal the unit.

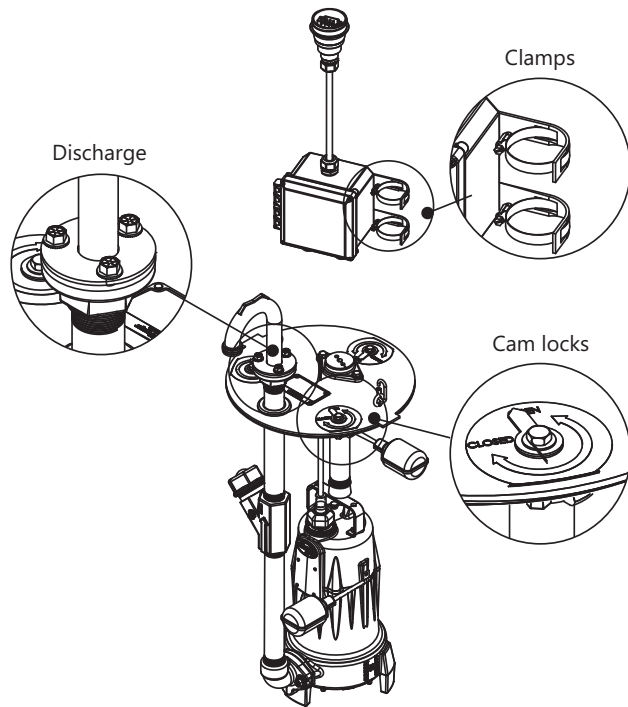

9. Open the valve so that the handle/latch encompasses the discharge elbow. If problems exist with opening the valve, adjustments can be made to the height of the discharge elbow by loosening the three screws on the discharge flange and raising or lowering the height as needed. Verify screws are re-tightened after adjustment.
10. The control box is designed to be mounted higher in the pit's access chamber and above a potential flood level should a power outage occur. Ten feet of cable is provided to the control box to accommodate various pit heights. Mount the control box as high as possible to the existing vent pipe using the supplied brackets and hose clamps. The brackets must first be screwed onto the control panel, then install the hose clamps through the slotted openings on the bracket.
11. The 6-pin electrical connector (either round or square) will mate up with the existing E/One plug in the pit. No splicing is required. Simply connect the plugs together and ensure they are fully engaged.
Note: The manual override switch will remain operational in the original equipment E/One panel.
12. An auxiliary or second nameplate is provided and should be fastened to the existing control panel to properly identify the new pump.

Operation

Starting System

1. With all electrical and mechanical connections complete and secure, turn on power to pump and control panel, if applicable.
2. Verify operation of the pump, floats, and alarm circuits.

3. Run several cycles of water through the system to verify correct control operation for the installation.

Note: The alarm float acts as a redundant ON float, activating the alarm and pump in the event of a main float switch failure.

Maintenance and Troubleshooting

Refer to supplied Omnivore Installation manual.

Warranty

Liberty Pumps Wholesale Products Limited Warranty

Liberty Pumps, Inc. warrants that Liberty Pumps wholesale products are free from all factory defects in material and workmanship for a period of three (3) years from the date of purchase (excluding* batteries and "Commercial Series" models). The date of purchase shall be determined by a dated sales receipt noting the model and serial number of the pump. The dated sales receipt must accompany the returned pump if the date of return is more than three years from the date of manufacture noted on the pump nameplate.

The manufacturer's sole obligation under this Warranty shall be limited to the repair or replacement of any parts found by the manufacturer to be defective, provided the part or assembly is returned freight prepaid to the manufacturer or its authorized service center, and provided that none of the following warranty-voiding characteristics are evident:

The manufacturer shall not be liable under this Warranty if the product has not been properly installed, operated, or maintained per manufacturer instructions; if it has been disassembled, modified, abused, or tampered with; if the electrical cord has been cut, damaged, or spliced; if the pump discharge has been reduced in size; if the pump has been used in water temperatures above the advertised rating; if the pump has been used in water containing sand, lime, cement, gravel, or other abrasives; if the product has been used to pump chemicals, grease, or hydrocarbons; if a non-submersible motor has been subjected to moisture; or if the label bearing the model and serial number has been removed.

Liberty Pumps, Inc. shall not be liable for any loss, damage, or expenses resulting from installation or use of its products, or for indirect, incidental, and consequential damages, including costs of removal, reinstallation or transportation.

There is no other express warranty. All implied warranties, including those of merchantability and fitness for a particular purpose, are limited to three years from the date of purchase. This Warranty contains the exclusive remedy of the purchaser, and, where permitted, liability for consequential or incidental damages under any and all warranties are excluded.

*Liberty Pumps, Inc. warrants StormCell® batteries for 1 year from date of purchase, and warrants that pumps of its Commercial Series are free from all factory defects in material and workmanship for a period of 18 months from the date of installation or 24 months from the date of manufacture, whichever occurs first, and provided that such products are used in compliance with their intended applications as set forth in the

technical specifications and manuals.

