

Installation Instructions

5693000G

Guide Rail Systems

Models

GR22-LE 2" Discharge

Fits LE70, LE100, LEH100, LEH150, and LEH200 Series Pumps

GR22NS-LE 2" Discharge Non-Sparking

Fits XLE50, XLE70, XLE100, and XLE150 Series Pumps

GR22-FL 2" Discharge

Fits FL50, FL60, FL70, FLH60, FL100, FL150, and FL200 Series Pumps

GR22NS-FL 2" Discharge Non-Sparking

Fits XFL50, XFL70, XFL100, and XFL150 Series Pumps

GR22-S 2" Discharge

Fits LE40, LE50, and PRG Series Pumps

Features

- Heavy-duty cast iron construction
- Accommodates single 1-1/4" guide pipe and 2" discharge pipe (depending on model)
- Auto-alignment feature
- Upper rail support bracket
- Includes sealing grommet
- Available in non-sparking version for hazardous locations with heavy-duty bronze claw



IMPORTANT: All Liberty Pump models are supplied with their own separate Installation/Operation/Maintenance manual(s). Ensure receipt of these manuals, and that they are read and understood prior to installing this unit. For questions, call Liberty Pumps customer service at 800-543-2550.

GR22 Assembly

The GR22 quick disconnect assembly provides easy installation and removal of the pump. When installed correctly, it will seal and provide support for the pump. Please ensure that installation is done per the diagrams shown.

The rail system comes in three parts:

Base: This is the large casting that is mounted to the floor of the pumping chamber or vault. One-half inch studs are recommended, spaced at 5.5" apart.

Pump mounting claw: Liberty Pumps offers three different pump mounting claws. The LE claw has a larger flange and fits LE-Series sewage pumps. The FL claw mates to FL-Series effluent pumps. Both GR22-LE and GR22-FL claws are threaded 2" FNPT for optional mounting applications. The GR22-S claw has a 2" NPT male thread for pumps with threaded discharges.

Support bracket: A small casting is supplied and is used to support the top end of the 1-1/4" guide rail pipe (pipe not included). This casting needs to be mounted to a support structure, bar stock, angle iron, or other means that attaches to the side walls of the vault.

Preparation

The claw have a sealing grommet attached to it that provides the seal between the claw and base unit. The sealing grommet should be cleaned and greased before every new installation with a silicone based grease which is provided. For the GR22-LE and GR22-FL, a gasket should be used between the claw and pump—the gasket and mounting hardware are provided with the pump. The stock flange that is shipped with the pump should be removed and replaced with the claw.

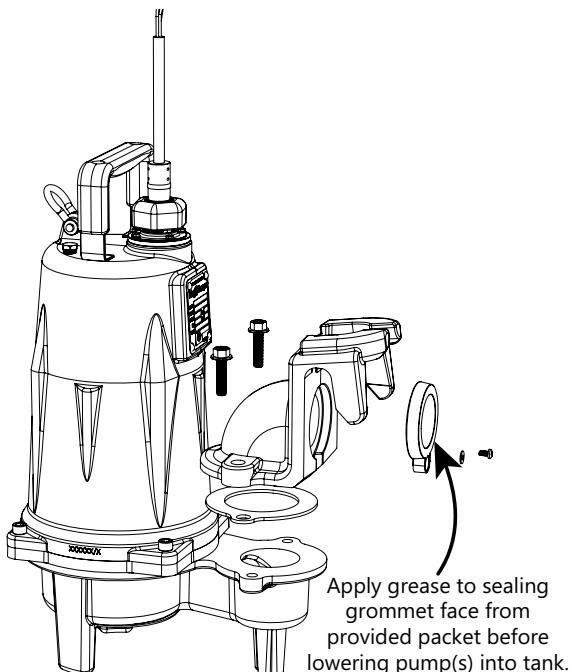

Installation

Note: a heavy guide rail pipe of galvanized or stainless steel is recommended.

A Support bracket shown in guide pipe rail

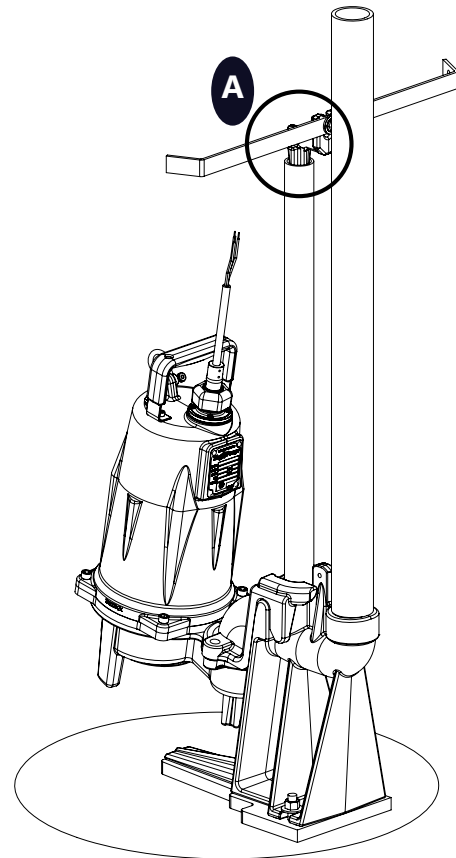

Model GR22-S

The Model GR22-S features a split design for pumps without a flange. The threaded base can be screwed into the pump's discharge and then the claw and gasket can be mounted.

