

# LENOVA<sup>®</sup>

DESIGN INSPIRED BY FUNCTION

---

4580 W Roosevelt Rd Hillside, IL 60162 [www.Lenovasinks.com](http://www.Lenovasinks.com) Phone: 877-733-1098

## SPECIFICATIONS

MODEL SS-AP2LE-S30

## Double Ledge Functional Design

### GENERAL

Fine quality sink formed of heavy duty 16 gauge, type 304 nickel bearing stainless steel.

### DESIGN FEATURES

Bowl depth 10" with inside bowl dimensions 27-4/5" X 19", and over all 29-4/5" X 22-4/5".

**Finish:** Inside bowl surfaces polished to a uniform satin finish.

**Underside:** High density sound absorption pads covered with a thick rubberized insulation layer on all bottom surfaces.

**Other:** Drain opening 3 1/2".





A-CB18



A-CLDR18



SS-ACLE18



SS-ACGRAP19



A-CB19

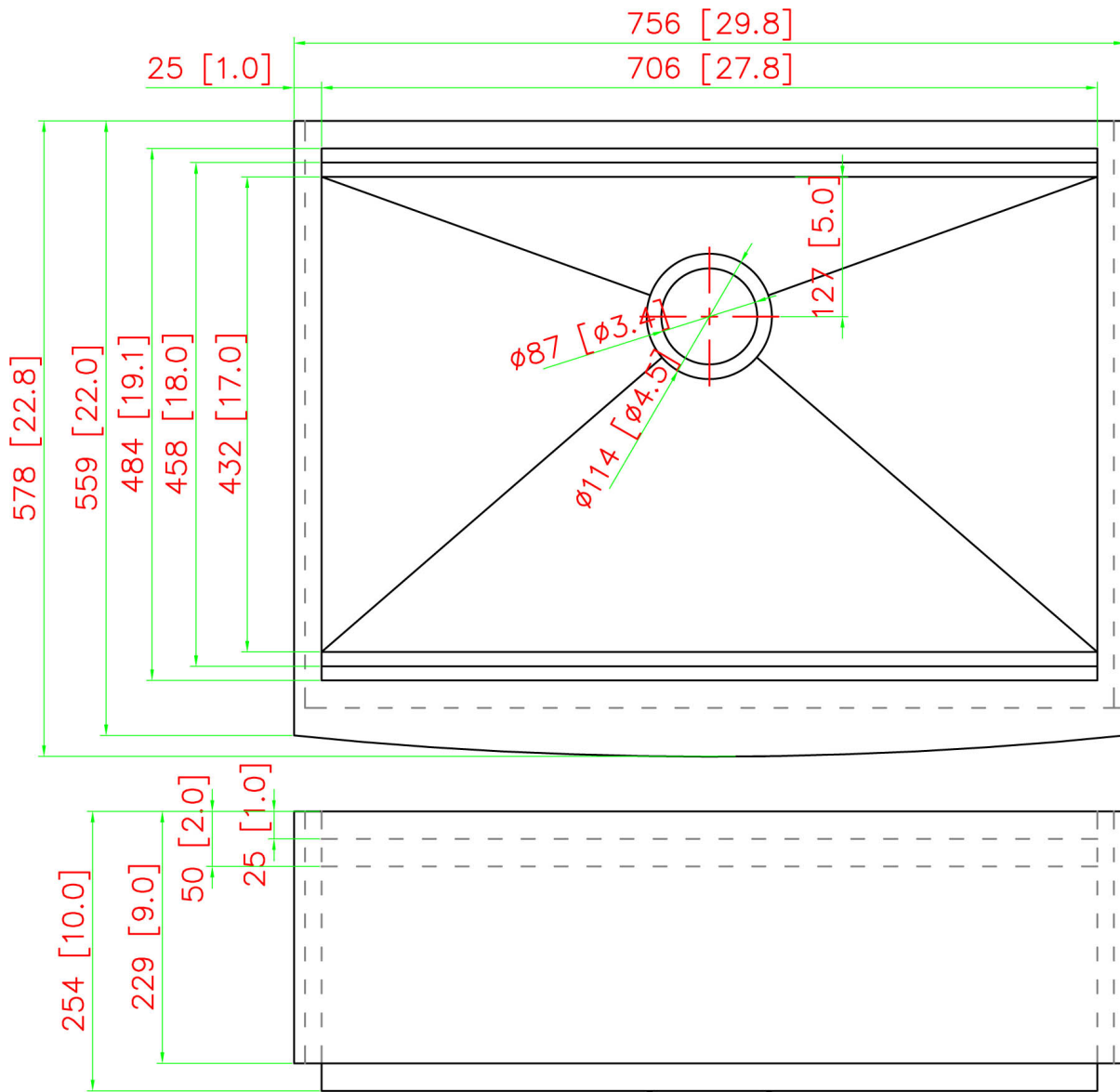

**DOUBLE LEDGE FUNCTIONAL DESIGN  
SINGLE BOWL APRON FARM SINK  
UNDERMOUNT**

SS-AP2LE-S30 (30 x 22 3/4 x 10)

**ACCESSORIES**

**Grid:** GASLE30  
**Sink Strainer:** A-SS-01,  
A-SS-02, A-SS-05

**DOWN LEVEL ACCESSORIES**

**Rolling Grid:** SS-AC-GR18  
**Colander:** A-CLDR18, SS-AC-LE18  
**Bamboo Cutting Board:** A-CB-18

**UP LEVEL ACCESSORIES**

**Rolling Grid:** SS-AC-GRAP19  
**Colander:** SS-AC-LEAP3  
**Bamboo Cutting Board:** A-CB19



**CUPC certified**

Minimum cabinet size 30"

**Warranty:**

Limited Life Time warranty against manufacturer defects and craftsmanship.

**Codes/Standards Applicable:**

ASME A112.19.3/CSA B45.4

\*Template and mounting clips are packed with every sink