



Montage- und Serviceanleitung  
Instructions de montage et d'entretien  
Istruzioni di montaggio e di assistenza  
Instrucciones de montaje y servicio  
Installation and service instructions

802353

Küchenmischer  
Mitigeur de cuisine  
Miscelatore da cucina  
Mezclador de cocina  
Kitchen faucet

## KWC ONO highflex®

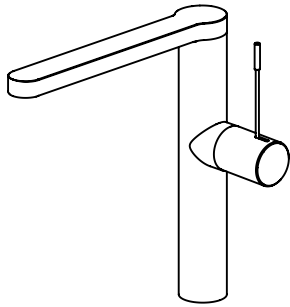

10.151.413.000  
10.151.413.700

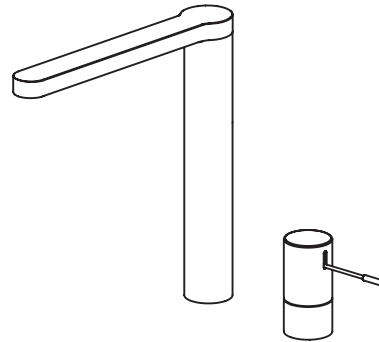

10.152.413.000

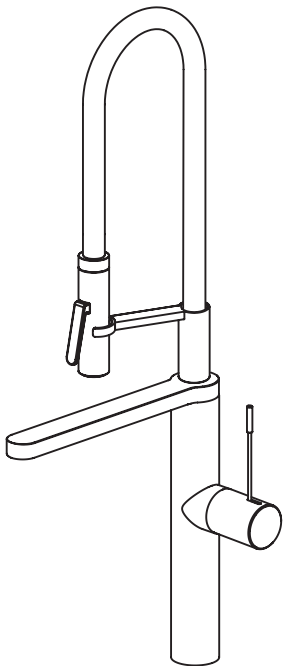

10.151.423.000  
10.151.423.700

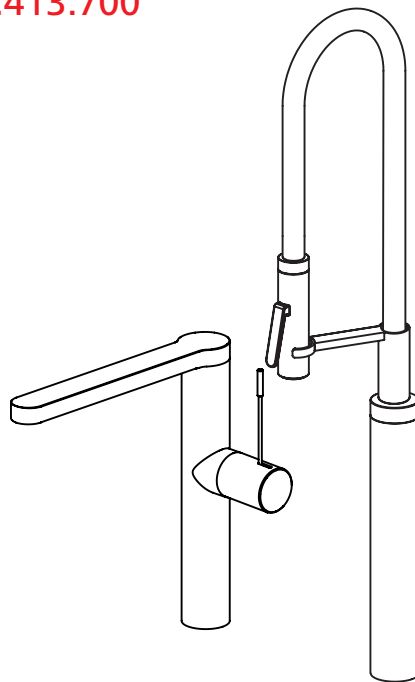

10.152.423.000

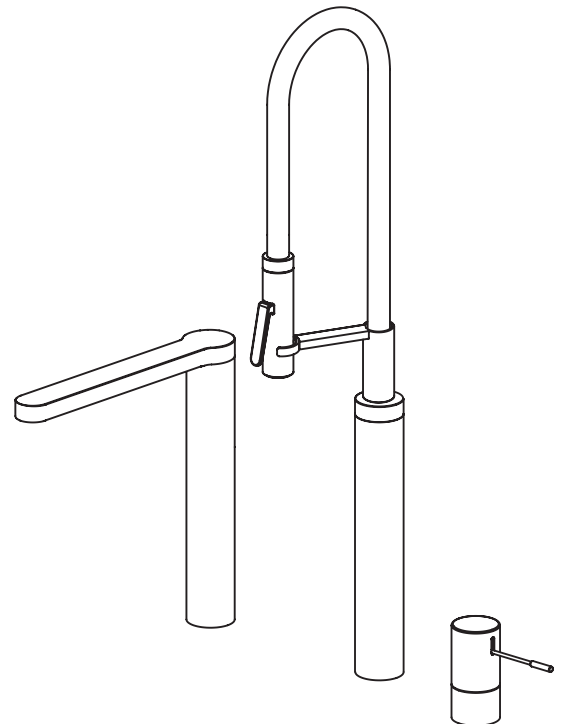

10.153.423.000

Idealer Betriebsdruck : 3 bar  
 Max. Betriebsdruck : 5 bar  
 Min. Betriebsdruck : 1 bar  
 Druckgleichheit empfehlenswert.  
 Ideale Wassertemperatur : 60°C  
 Max. Wassertemperatur : 70°C



**Achtung:**  
 Vor Montage die Leitungen gründlich durchspülen!

Weitere Informationen finden Sie in unseren detaillierten Verkaufsunterlagen.

Pressione di servizio ideale : 3 bar  
 Pressione di servizio mass. : 5 bar  
 Pressione di servizio min. : 1 bar  
 Si raccomanda pressioni uguali.  
 Temperatura acqua calda ideale : 60°C  
 Temperatura acqua calda mass. : 70°C



**Attenzione:**  
 Risciacquare bene le tubazioni prima del montaggio!

Ulteriori informazioni le troverete nelle nostre dettagliate documentazioni.

Pression de service idéale : 3 bar  
 Pression de service max. : 5 bar  
 Pression de service min. : 1 bar  
 Egalité de pression recommandée.  
 Température idéale de l'eau : 60°C  
 Température max. de l'eau : 70°C



**Attention:**  
 Rincer à fond la tuyauterie avant le montage!

Pour informations supplémentaires voir nos documentations de vente détaillées.

KWC VG  
 KWC Deutschland GmbH  
 Junghansring 70  
 DE-72108 Rottenburg  
 +49 (0) 7457 948 56 0  
 +49 (0) 7457 948 56 30

Franke WS/KS  
 Franke S.p.A.  
 Via Pignolini 2  
 IT-37019 Peschiera del Garda  
 +39 (045) 644 931 1

Franke WS  
 Franke GmbH  
 Oberer Achdamm 52  
 AT-6971 Hard  
 +43 (0) 557 467 350  
 +43 (0) 557 462 411

Franke WS/KS  
 Franke L.L.C.  
 RAK Industrial Zone, P.O. Box 14511  
 AE-Ras Al Khaimah, UAE  
 +971 7 203 47 00  
 +971 7 203 47 60

Franke KS  
 Franke GmbH  
 Mumpferfährstrasse 70  
 DE-79713 Bad Säckingen  
 +49 (0) 7761 52 0  
 +49 (0) 7761 52 294

Franke KS  
 Franke France S.A.S.  
 Avenue Aristide Briand BP 13  
 FR-60230 Chambly  
 +331 30 28 94 00  
 +331 30 28 94 30

Presión ideal de servicio : 3 bar  
 Presión máxima de servicio : 5 bar  
 Presión mínima de servicio : 1 bar  
 Se recomienda la igualdad de las presiones.  
 Temperatura ideal del agua : 60°C  
 Temperatura máxima del agua : 70°C



**Atención:**  
 ¡Enjuagar escrupulosamente las tuberías antes del montaje!

Información más detallada en nuestra documentación de ventas.

Ideal operating pressure : 3 bar / 45 PSI / 300 kPa  
 Max. operating pressure : 5 bar / 70 PSI / 500 kPa  
 Min. operating pressure : 1 bar / 14.5 PSI / 100 kPa  
 Equal pressures are recommended.  
 Ideal water temperature : 60°C (140°F)  
 Max. water temperature : 70°C (158°F)



**Attention:**  
 Flush pipes thoroughly before installation!

For further information refer to our detailed sales literature.

Driftstryck : 3 bar / 300 kPa  
 Max. tryck : 5 bar / 500 kPa  
 Min. tryck : 1 bar / 100 kPa  
 Lika tryck på kall- och varmvatten rekommenderas.  
 Driftstemperatur : 60°C  
 Max temperatur : 70°C



**O.B.S.**  
 Spola rören ordentligt innan blandare installeras!

För ytterligare information se produktblad.

Franke WS/KS  
 Franke Consumer Products  
 Luxury Products Group  
 800 Aviation Parkway  
 Smyrna, TN 37167 USA  
 +1 800-626-5771

Franke WS  
 Franke Water Systems  
 Ring-Oost 10  
 BE-9400 Ninove  
 +32 (0) 54 31 01 30  
 +32 (0) 54 31 01 35

Franke KS  
 Franke UK Limited  
 West Park, MIOC, Styal Road  
 GB-Manchester M22 5WB  
 +44 161 436 62 80  
 +44 161 437 13 79

Franke KS  
 Franke NV  
 Ring 10  
 BE-9400 Ninove  
 +32 (0) 54 31 01 11  
 +32 (0) 54 32 36 88

Franke KS  
 Franke Nederland B.V.  
 Lagedijk 13  
 NL-5705 Bx Helmond  
 +31 492 585 111  
 +31 492 585 200

**Umgebungsbedingungen**

In unmittelbarer Nähe von Armaturen und Anschlussschläuchen dürfen keine Reinigungsmittel und Chemikalien gelagert werden.

Austretende Dämpfe können die Armatur und die Anschlussschläuche beschädigen.

**Conditions d'environnement**

Aucun produit de nettoyage ni détergent chimique ne doit être stocké à proximité immédiate des robinetteries et des raccords flexibles.

Les vapeurs qui s'en échappent risqueraient d'endommager les robinetteries et les raccords flexibles.

**Ambiente circostante**

Non conservare detersivi o sostanze chimiche nelle immediate vicinanze della rubinetteria e dei tubi flessibili di collegamento.

L'esalazione di vapori potrebbe danneggiare la rubinetteria e i tubi flessibili.

**Condiciones del entorno**

Cerca de las griferías y conexiones de tubos flexibles no se deben almacenar productos químicos ni de limpieza.

Los eventuales vapores podrían dañar la grifería y las conexiones de tubos flexibles.

**Environmental conditions**

No cleaning agents or chemicals should be stored in the immediate vicinity of faucets and connection hoses.

Any vapour emitted may damage the faucet and connection hoses.

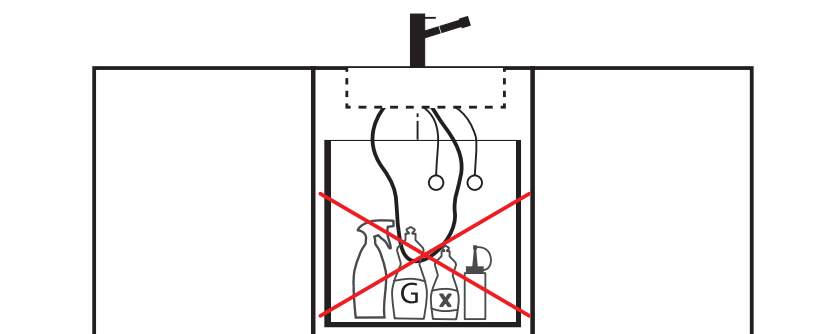
**Periodische Kontrolle**

Die Anschluss- und Brausenschläuche müssen aus Sicherheitsgründen periodisch auf folgende Punkte kontrolliert werden:

**Dichtheit**

Feuchte oder tropfende Schläuche müssen ersetzt werden.

**Korrosionsschäden**

Schläuche mit rostiger oder oxidierter Oberfläche müssen ersetzt werden.

**Mechanische Beschädigung**

Schläuche, welche eine mechanische Beschädigung aufweisen, müssen ersetzt werden.

**Contrôle périodique**

Pour des raisons de sécurité, les flexibles de douche et de raccordement doivent être contrôlés périodiquement pour vérifier les points suivants:

**Etanchéité**

Les flexibles humides ou qui gouttent doivent être remplacés.

**Dommages dus à la corrosion**

Les flexibles oxydés en surface doivent être remplacés.

**Dommages mécaniques**

Les flexibles qui présentent des dommages mécaniques doivent être remplacés.

**Controlli periodici**

Per ragioni di sicurezza, è necessario sottoporre a controlli periodici i tubi flessibili di collegamento e delle docce in merito ai seguenti aspetti.

**Tenuta**

I tubi umidi o non a tenuta devono essere sostituiti.

**Danni da corrosione**

I tubi che presentano una superficie arrugginita oppure ossidata devono essere sostituiti.

**Danni meccanici**

I tubi che presentano danni meccanici devono essere sostituiti.

**Control periódico**

Por razones de seguridad, las conexiones de tubos flexibles y los flexos de ducha se deben controlar periódicamente respecto a los siguientes puntos:

**Estanqueidad**

Se deben sustituir los tubos flexibles húmedos o que gotean.

**Daños por corrosión**

Se deben sustituir los tubos flexibles con óxido o herrumbre en la superficie.

**Daños mecánicos**

Se deben sustituir los tubos flexibles que presentan daños mecánicos.

**Periodic checks**

For safety reasons, the connection and shower hoses must be checked periodically for the following:

**Watertightness**

Damp or dripping hoses must be replaced.

**Corrosion**

Hoses with rusty or oxidized surfaces must be replaced.

**Mechanical damage**

Hoses that show signs of mechanical damage must be replaced.

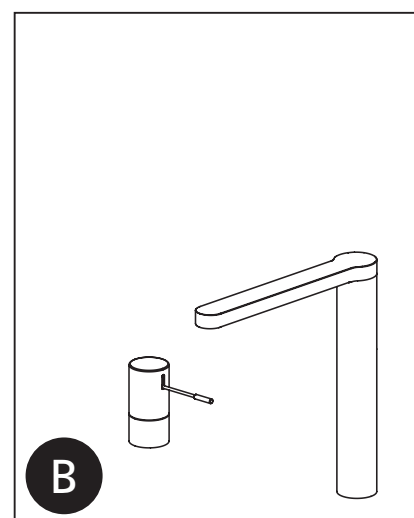
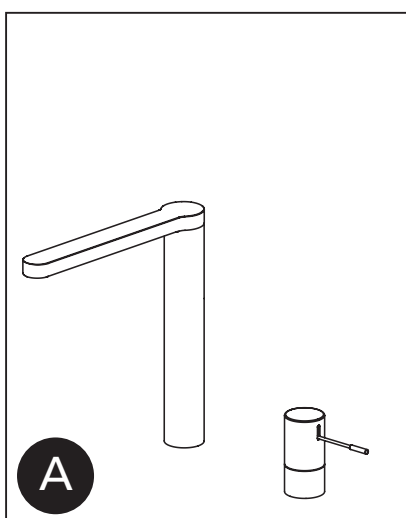
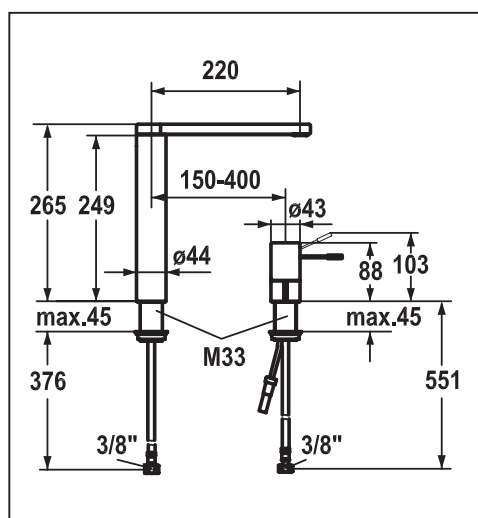
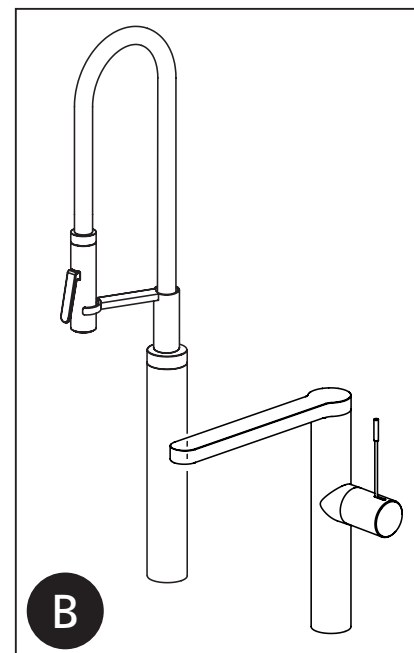
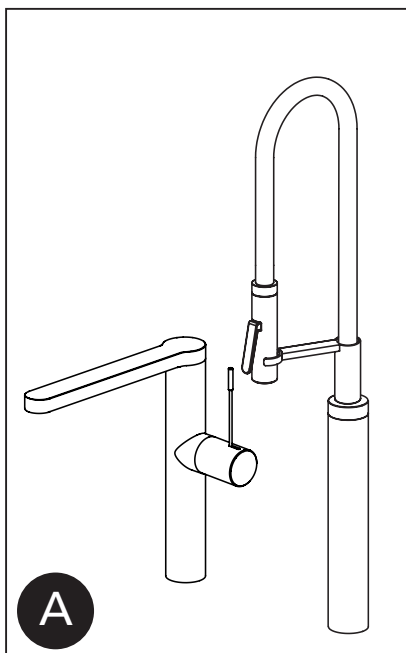
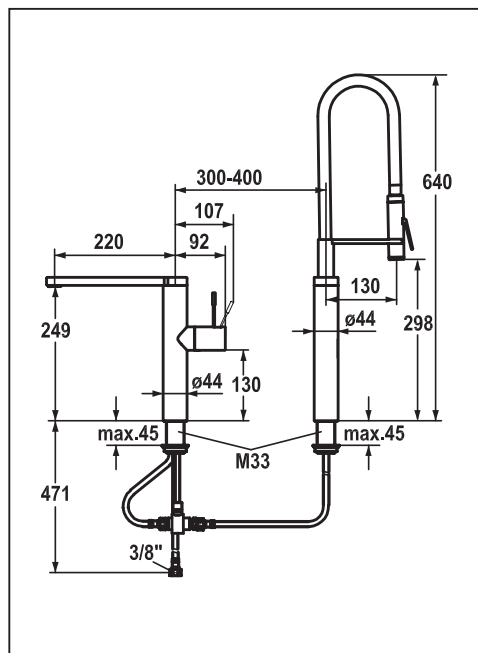

Montagebeispiele  
 Exemples de montage  
 Esempi di montaggio  
 Ejemplos de montaje  
 Examples of assembly

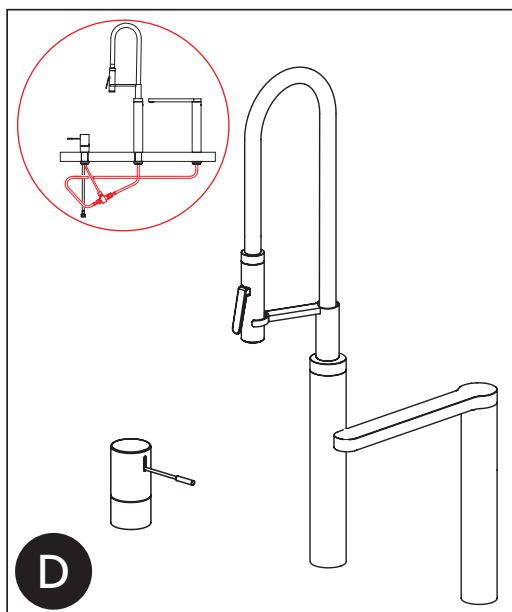
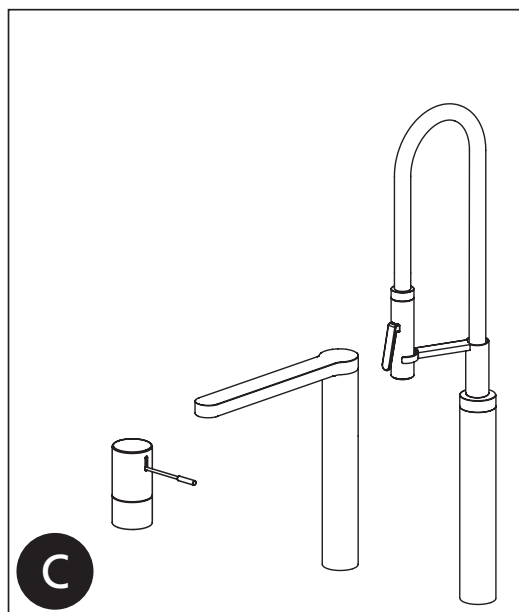
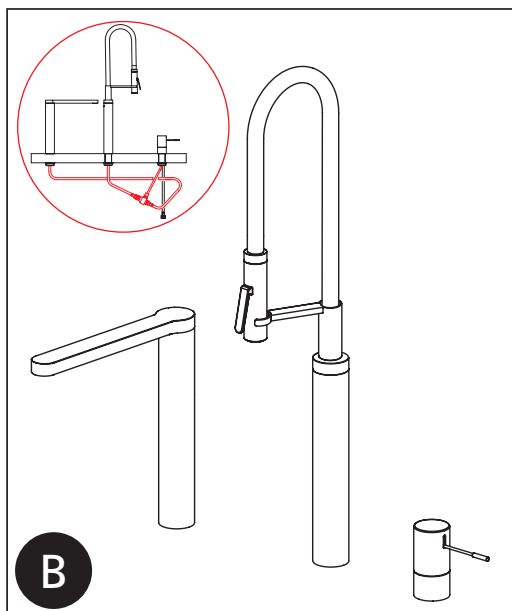
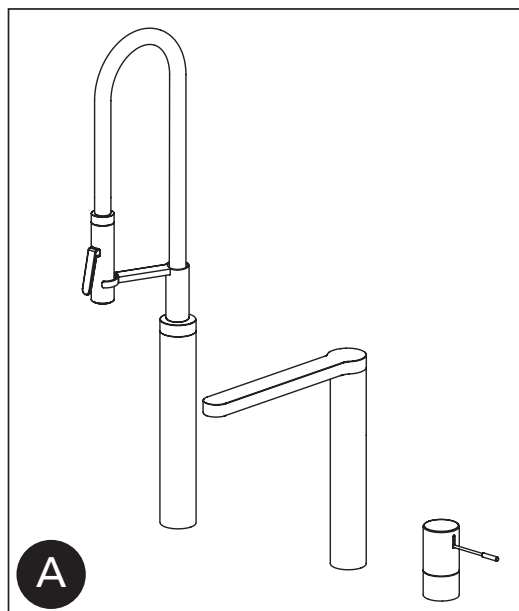
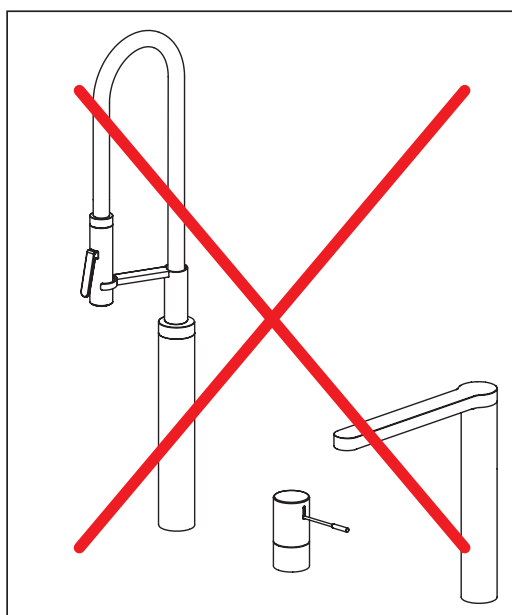
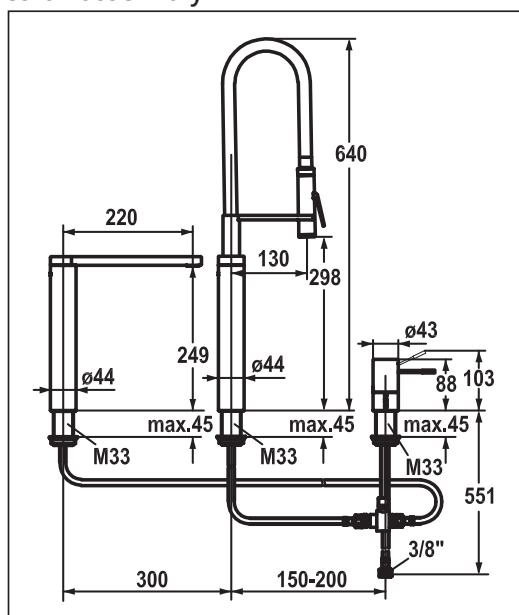

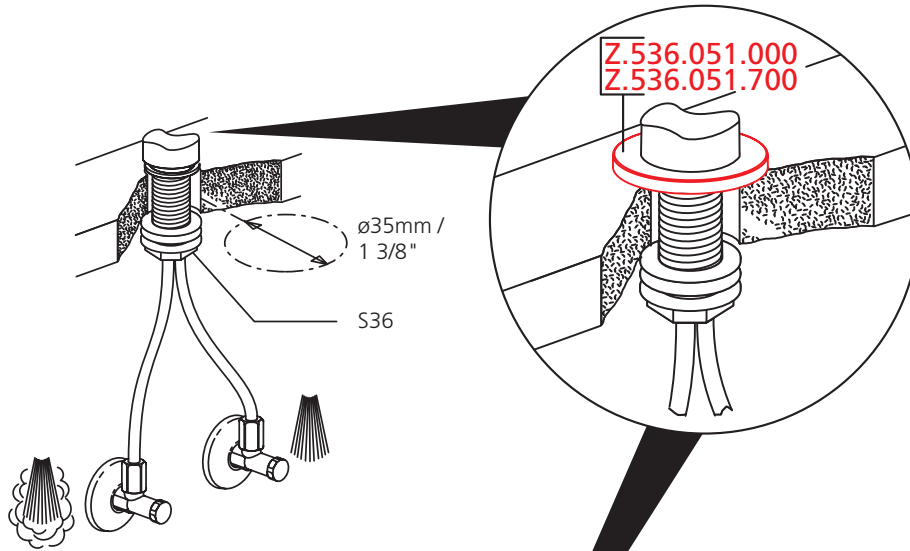

**EU/AUS**

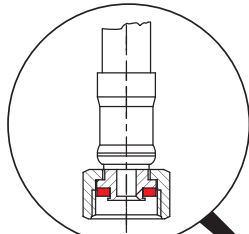

**USA/CAN**

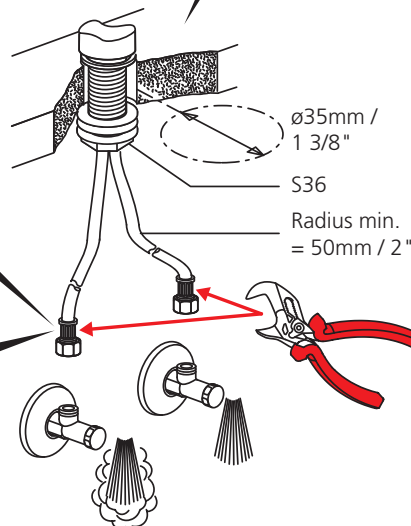
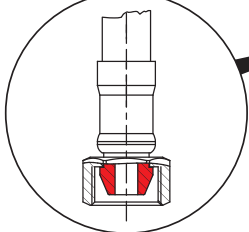

Beim Anschliessen zwingend  
 gemäss Abbildung  
 oberhalb der Mutter gehalten!

Pour le raccordement, il est impératif  
 d'appliquer une force contraire au-dessus  
 de l'écrou (voir illustration)!

Eseguire il collegamento sopra il  
 dado secondo la figura.

Al conectar, sujetar por encima de la  
 tuerca siguiendo exactamente el dibujo

Hold above the nut during installation  
 as shown in the illustration.

10.151.423.000  
 10.151.423.700

Filter-Set  
 Z.536.711

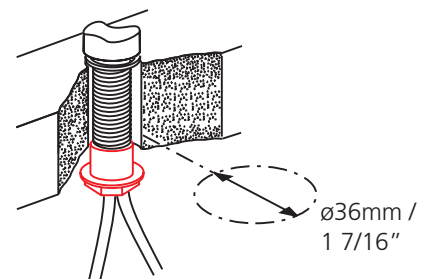
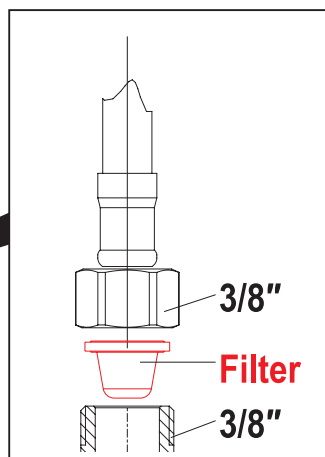
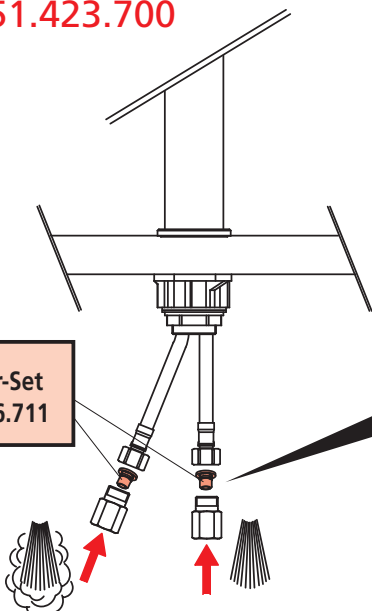

Z.503.315

Verlängerungsmutter L= 40mm  
 Ecrou allongé L= 40mm  
 Dado prolungato L= 40mm  
 Tuerca de prolongación L= 40mm  
 Extension nut L= 40mm / 1 1/2"

Spülen  
Rinçage  
Spurgare  
Limpieza  
Rinse

1

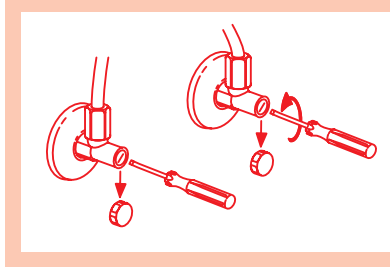

Kalt- und Warmwasser öffnen.  
Ouvrir eau froide et chaude.  
Aprire acqua fredda e calda.  
Abrir la salida de agua fría y caliente.  
Open cold and hot water.

2

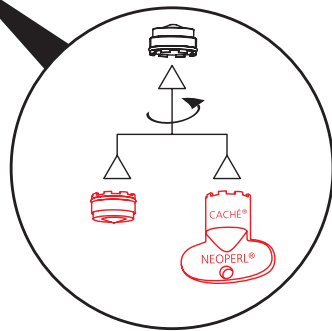

3

- |||||| D spülen
- |||||| F rincer
- |||||| I sciacquate
- |||||| Sp enjuagar
- |||||| E flush

4



Funktionen  
Fonctions  
Funzioni  
Funciones  
Functions

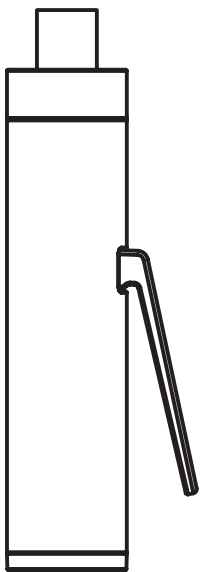

0

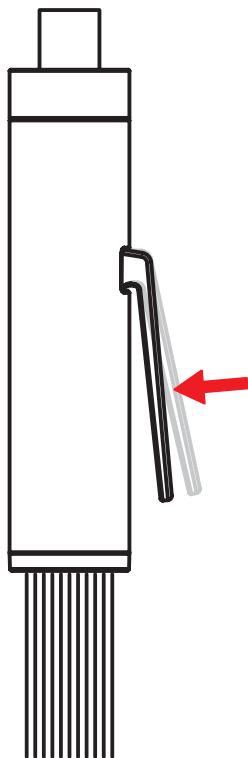

1

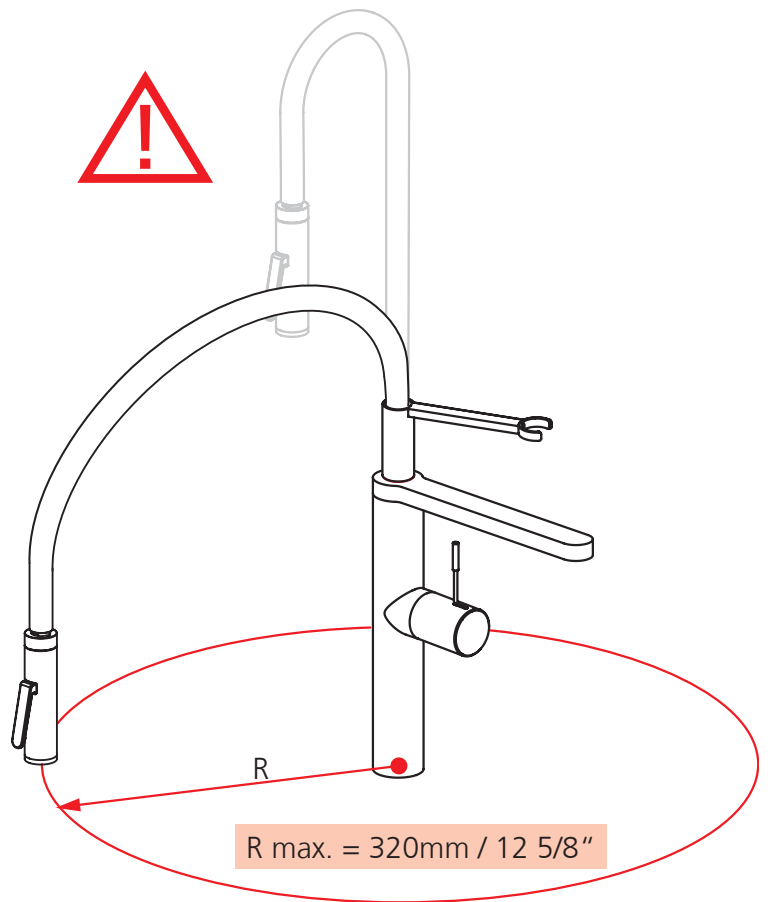

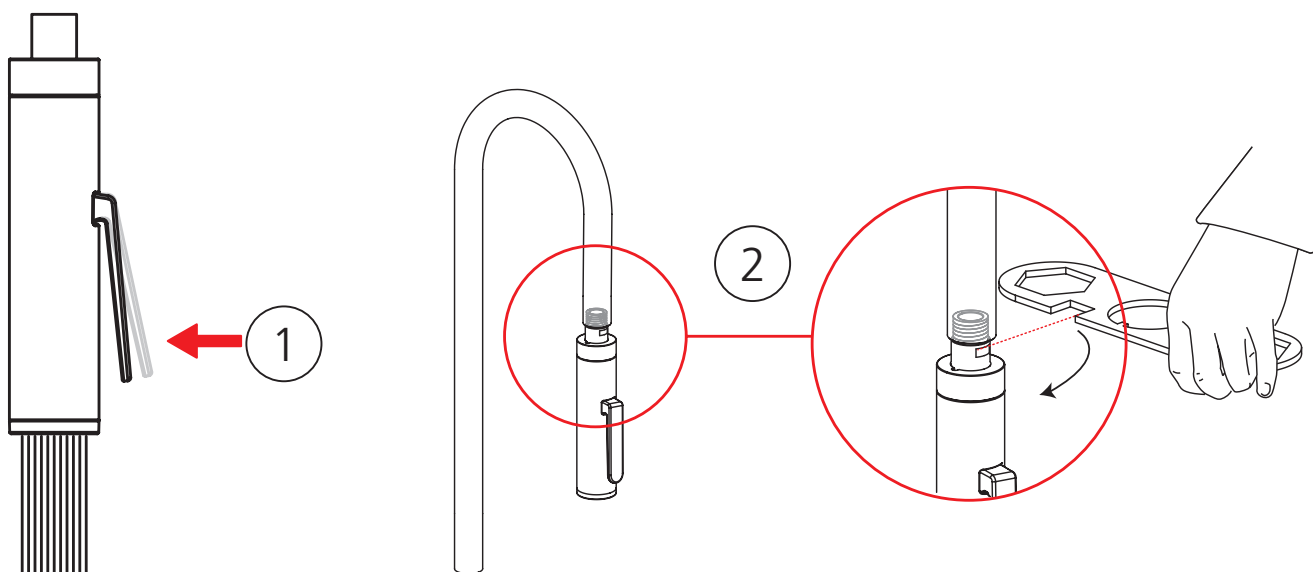

10.151.423.000  
 10.151.423.700

Demontage Umsteller  
 Demontage Inverseur  
 Smontaggio Deviatore  
 Desmontaje Inversor  
 Disassembling Diverter

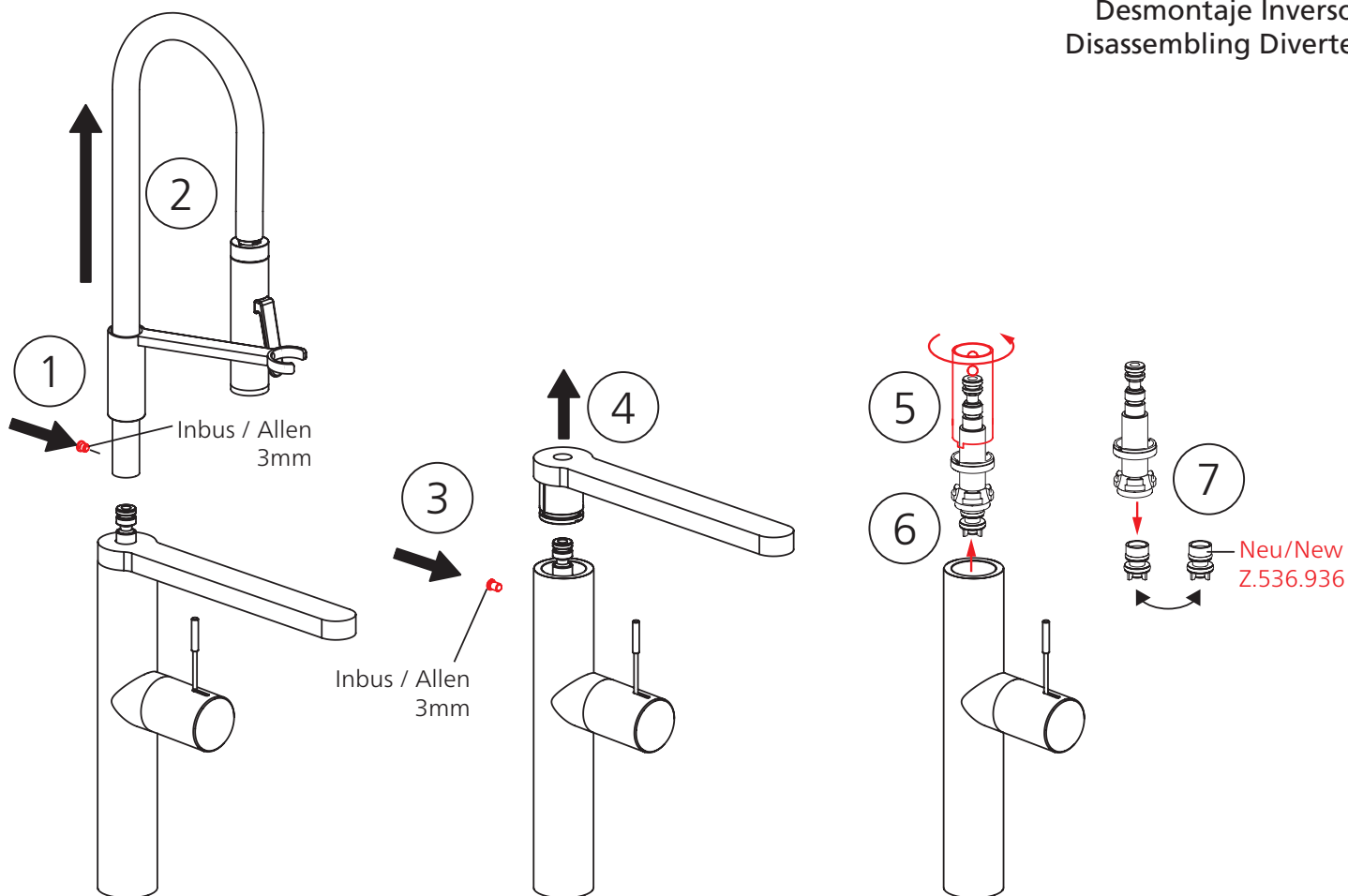



Montage  
Montage  
Montagio  
Montaje  
Installation

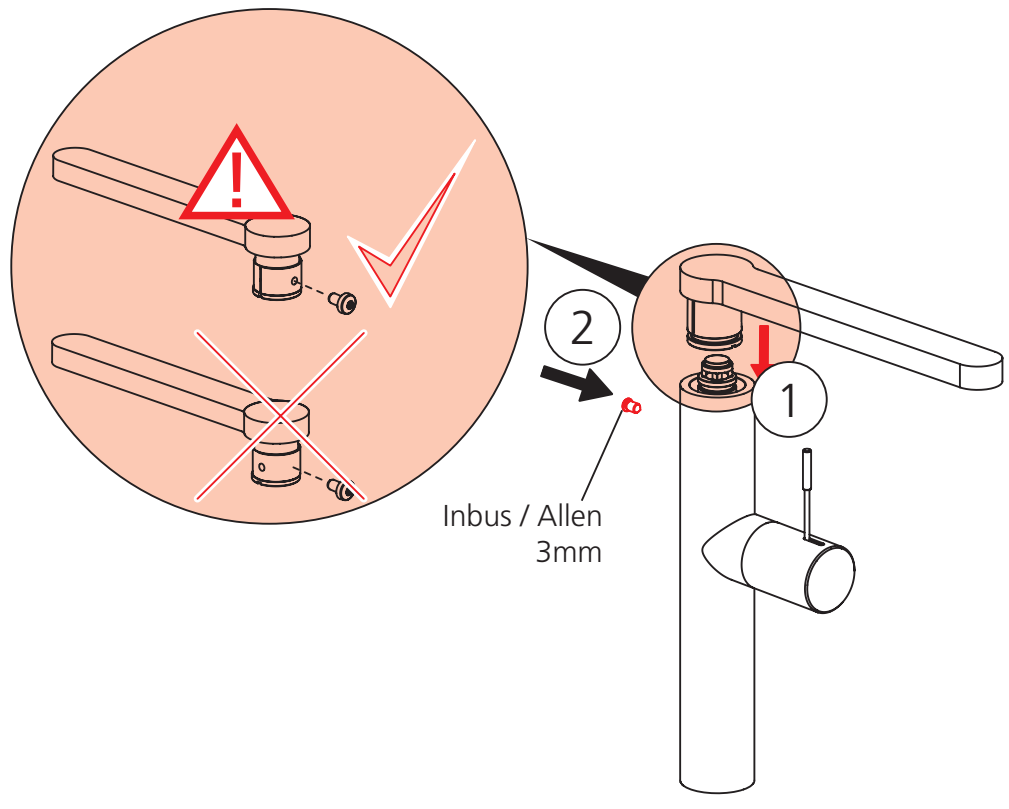

Montage  
Montage  
Montagio  
Montaje  
Installation

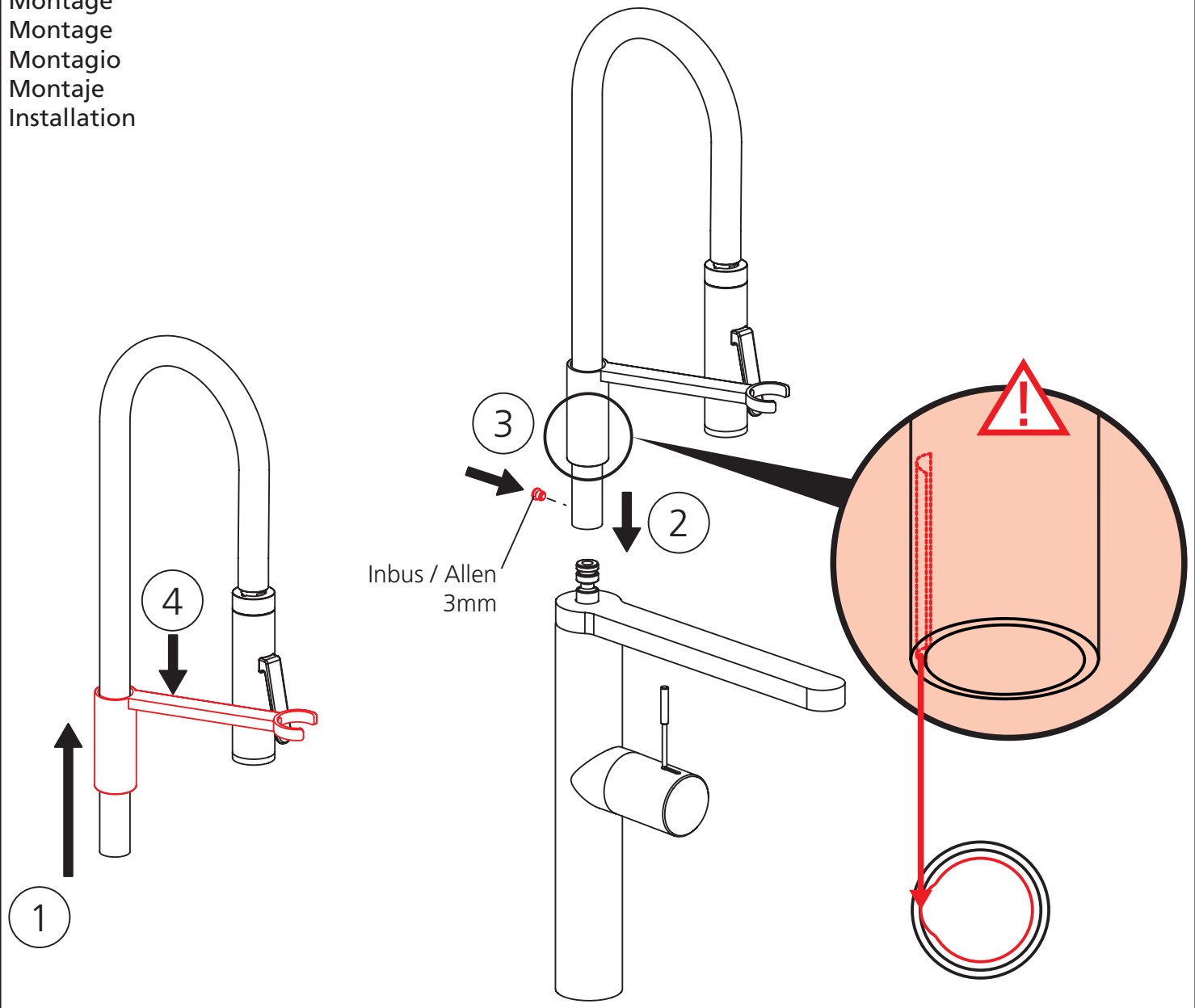

10.151.413.000  
10.151.413.700

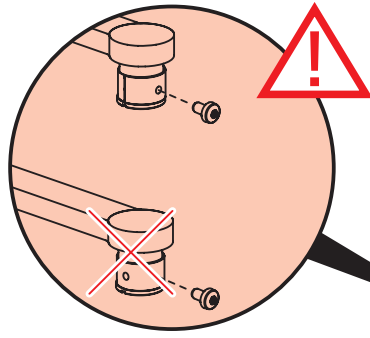

Z.535.965

Z.535.966

Z.536.042  
M24x1

Z.635.322.700

Z.537.582

12 Nm + 1 Nm

Z.634.912  
SW 32

Z.536.051.000  
Z.536.051.700

Z.635.276.700

Z.535.991.000  
Z.535.995.700

Z.536.288

Z.634.938.700

Z.535.664.000  
Z.535.664.700

Z.532.241

Z.535.967

ø 10 mm

Z.535.967

Z.532.241

M24x1  
Z.635.231

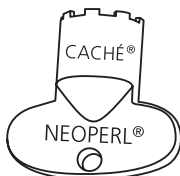

Adapter 3/8" x 1/2"

Z.535.739

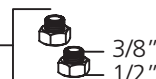

Z.635.392

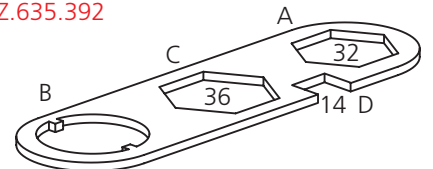

Ersatzteile  
Pièces de rechange  
Pezzi di ricambio  
Repuestos  
Spare parts

Es dürfen ausschliesslich **original Ersatzteile** verwendet werden!  
Utiliser seulement des **pièces de rechange originaux!**  
Usare soltanto i **pezzi di ricambio originali!**  
¡Utilizar solamente los **Requetos originales!**  
Only the **original Spare parts** may be used!

10.152.413.000

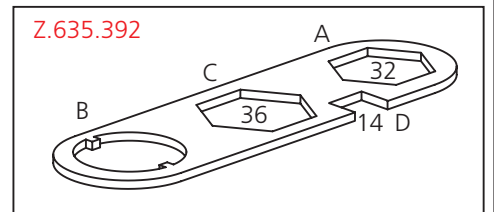
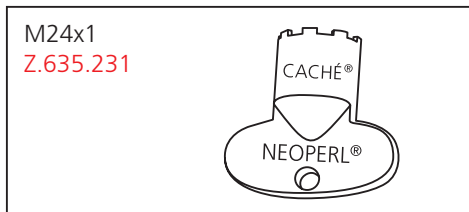
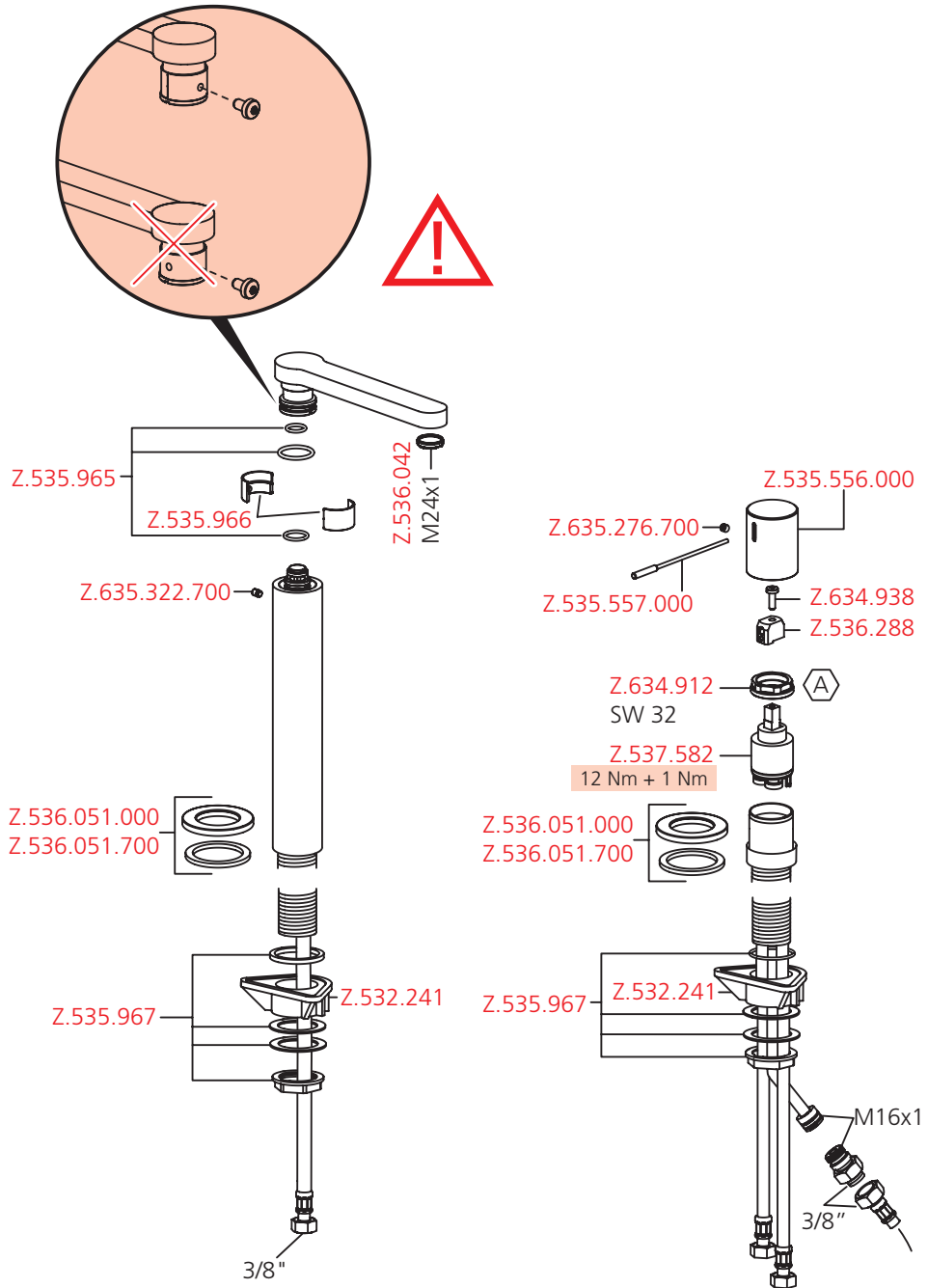

10.151.423.000  
10.151.423.700

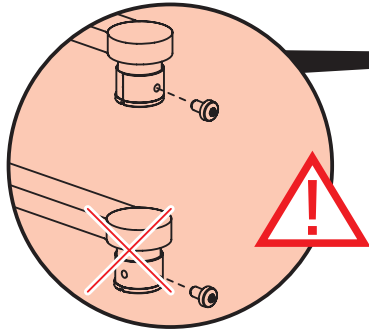
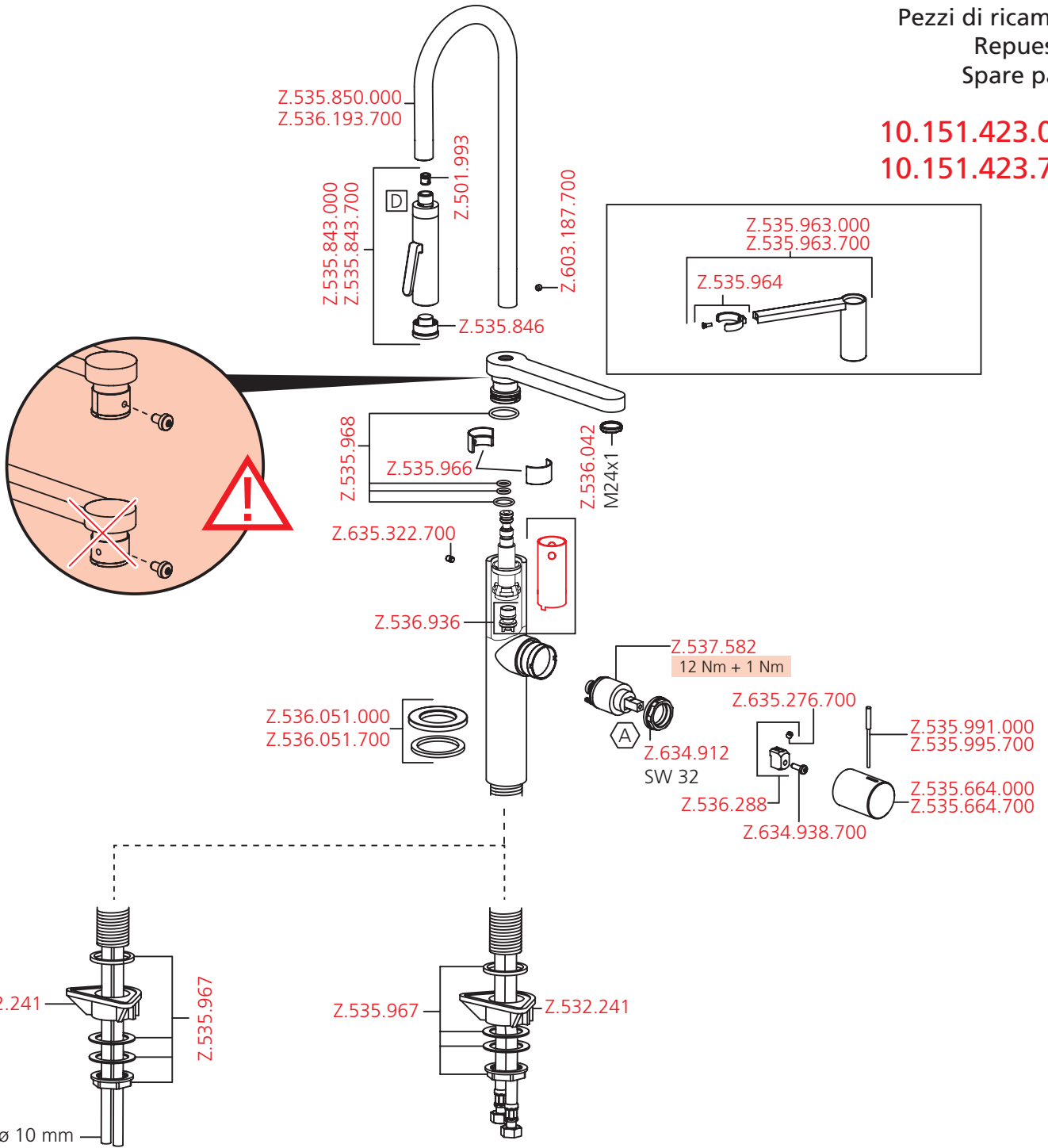

M24x1  
Z.635.231

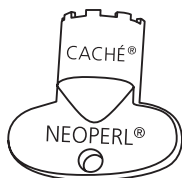

Adapter 3/8" x 1/2"

Z.535.739 3/8" 1/2"

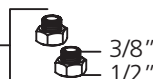

Z.635.392

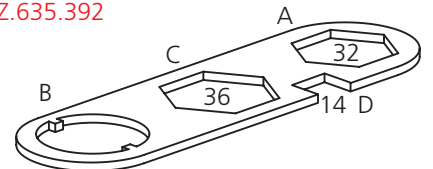

Ersatzteile  
Pièces de rechange  
Pezzi di ricambio  
Repuestos  
Spare parts

Es dürfen ausschliesslich **original Ersatzteile** verwendet werden!  
Utiliser seulement des **pièces de rechange originaux**!  
Usare soltanto i **pezzi di ricambio originali**!  
¡Utilizar solamente los **repuestos originales**!  
Only the **original spare parts** may be used!

10.152.423.000

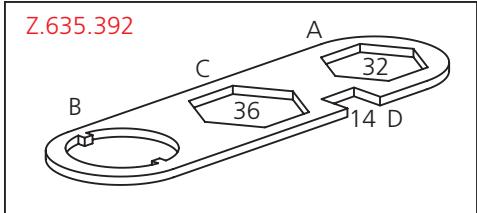
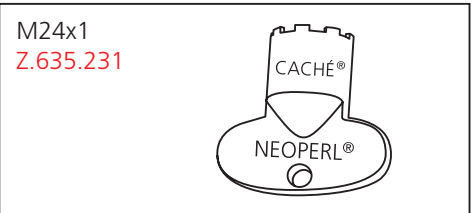
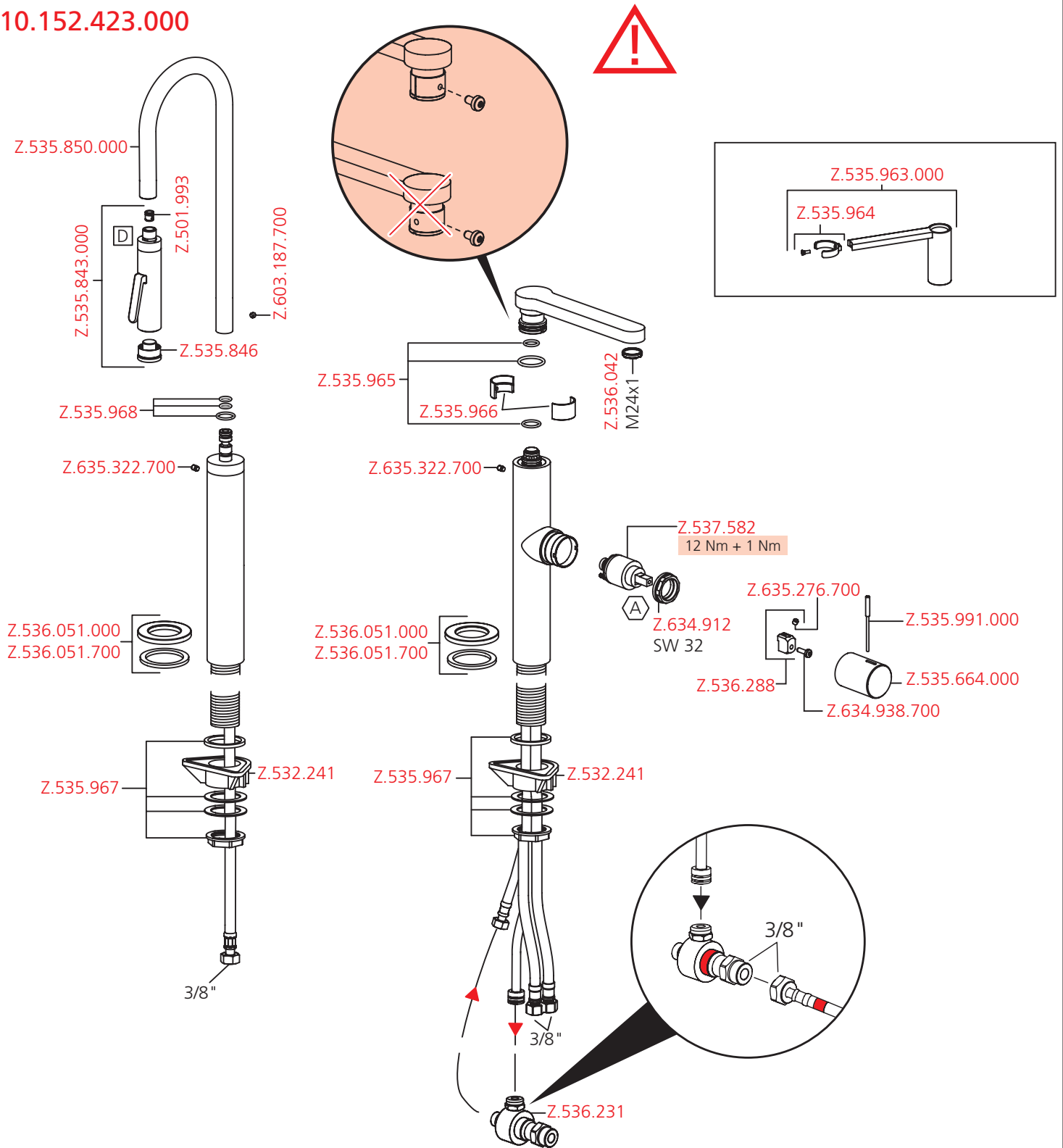

Es dürfen ausschliesslich **original Ersatzteile** verwendet werden!  
 Utiliser seulement des **pièces de rechange originaux!**  
 Usare soltanto i **pezzi di ricambio originali!**  
 ¡Utilizar solamente los **repuestos originales!**  
 Only the **original spare parts** may be used!

Ersatzteile  
 Pièces de rechange  
 Pezzi di ricambio  
 Repuestos  
 Spare parts

10.153.423.000

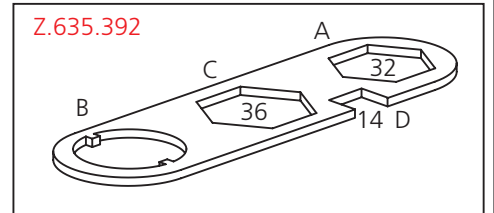
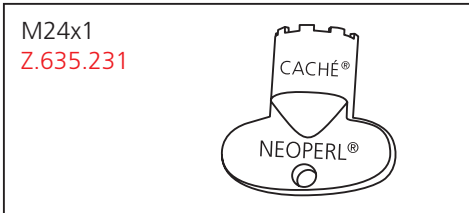
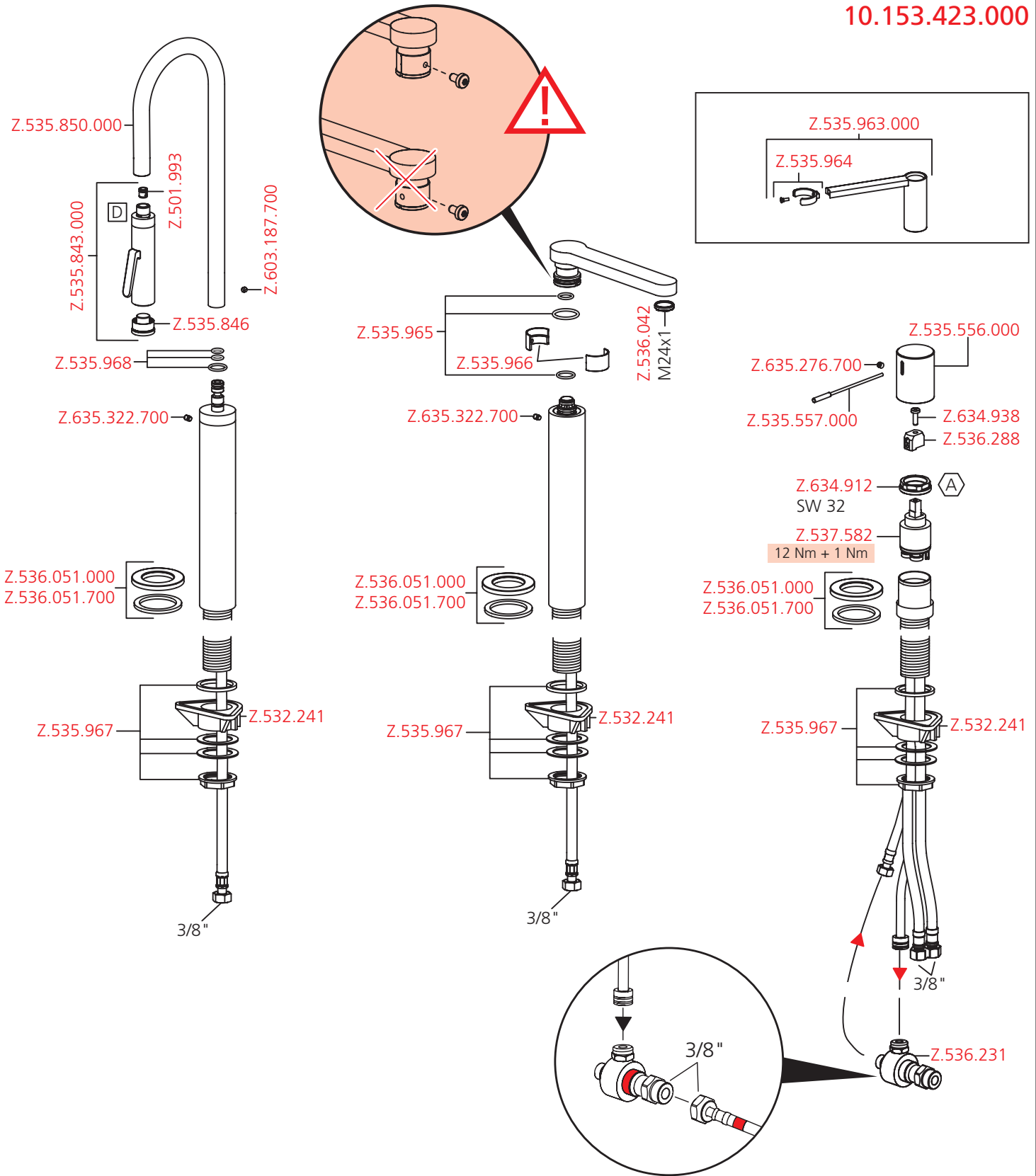

**Pflegeanleitung für Armaturen und Zubehör**  
**Instruction pour la maintenance des robinets et des accessoires**  
**Istruzioni per la manutenzione di rubinetti e accessori**  
**Instrucciones para el cuidado de griferías y accesorios**  
**Maintenance / Cleaning instructions for faucets and accessories**

**Grundsätzliche Reinigungshinweise:**

- Beim Reinigen muss die Oberfläche der Armatur kalt sein (Wärme beschleunigt die Zerstörung der Oberfläche)!
- Reinigungshinweise der Reinigungsmittelhersteller beachten!

**Die Pflege:**

- Armatur täglich mit weichem Lappen trocken reiben!
- Scheuernde Reinigungsmittel und Putzschwämme unbedingt vermeiden!

**Die Reinigung:**

- Schmutz- oder Kalkflecken auf der Armaturenoberfläche nur mit mildem Reinigungsmittel entfernen!
- Sofort nach dem Reinigen alle Reinigungsmittelrückstände mit kaltem Wasser wegspülen!
- Mit weichem Lappen trocken reiben.

**Instructions principales pour le nettoyage:**

- Durant le nettoyage, la surface du robinet doit être froide (la chaleur accélère l'usure de la surface)!
- Nous vous prions de faire attention aux indications mentionnées sur les nettoyages!
- Assurez vous que les produits ne contiennent pas d'acides ou des substances corrosives.

**L'entretien:**

- Le robinet doit être nettoyé chaque jour avec un chiffon mou.
- Evitez absolument l'usage des brillants pour métaux, éponges abrasives ou produits similaires!

**Le nettoyage:**

- Enlevez salissures et dépôts calcaires de la surface du robinet seulement avec des produits qui ne sont pas agressifs!
- Immédiatement après le nettoyage, rincer bien les résidus des détergents avec de l'eau froide!
- Sécher avec un chiffon mou.

**Principali istruzioni per la pulizia:**

- Durante la pulizia, la superficie del rubinetto deve essere fredda (il calore accelera il logorio della superficie)!
- Fare attenzione alle indicazioni riportate sui prodotti per la pulizia!
- Accertarsi che non contengano acidi o sostanze corrosive.

**La manutenzione:**

- Il rubinetto deve essere asciugato quotidianamente con un panno morbido.
- Evitare assolutamente paglietta, spugne abrasive o similari!

**La pulizia:**

- Togliere sporco e calcare dalla superficie del rubinetto solo con detersivi non aggressivi!
- Subito dopo la pulizia, sciacquare bene i residui di detersivo con acqua fredda!
- Asciugare con un panno morbido.

**Avisos básicos de limpieza:**

- Cuando se procede a limpiar la grifería, su superficie debe estar fría (el calor acelera la destrucción de la superficie)!
- Respetar los avisos de limpieza del fabricante del detergente!

**Cuidado:**

- Secar la grifería frotando diariamente con un paño blando!
- Evite, imprescindiblemente, detergentes y esponjas de limpieza raspantes!

**Limpieza:**

- Quitar las manchas de suciedad o cal en la superficie de la grifería sólo con un detergente poco agresivo!
- Inmediatamente después de la limpieza eliminar, enjuagando con agua fría, todos los residuos del detergente!
- Secar frotando con un paño blando.

**General Cleaning Instructions:**

- Faucet surface must be of room temperature before cleaning (elevated temperature increases damage of the surface).
- Cleaning instructions of the detergent manufacturer must be followed.

**Maintenance:**

- Rub the faucet daily dry with a soft cloth.
- Never use corrosive cleaners or cleaning pads.

**Cleaning:**

- Dirt or calcium deposits on the faucet surface must be removed with soft detergent or with soap water!
- Rinse well with water immediately after cleaning, until all detergent is removed from the surface.
- Dry with soft cloth.

**Skötsel och underhåll:**

- Blandaren skall vara rumstempererad innan rengöring (högre temperatur kan vara skadlig för ytbehandlingen).
- Instruktioner från rengöringsmedeltillverkaren skall följas.

**Underhåll:**

- Torka av blandaren dagligen med en mjuk trasa
- Använd aldrig kalklösande, sura- eller slipande skurmedel och svampar.

**Rengöring:**

- Smuts eller kalkavlagringar på blandarytan tas bort med mild rengöringsmedel eller mild tvålösning.
- Eftersköljning med rent vatten tills allt rengöringsmedel är borta.
- Torka med mjuk trasa.



- D Schäden, die infolge unsachgemässer Behandlung, natürlicher Abnutzung oder zu grosser Inanspruchnahme entstanden sind, sind von unseren Garantieleistungen ausgeschlossen!
- F Ces dommages survenus en raison d'un traitement inadéquat, des signes d'usure traitement inadéquat, naturels ou du grand utilisation, sont exclus de notre garantie.
- I Danni ai rubinetti, conseguenti da un trattamento non appropriato, sono esclusi dalla nostra garanzia!
- Sp Daños, debidos a un tratamiento inadecuado, son excluidos de la nuestra garantía.
- E Damages on the faucet resulting from incorrect handling are excluded from the manufacturers warranty!
- S För att Garantien skall gälla skall blandaren vara monterad och använd på ett korrekt sätt.

Technische Änderungen vorbehalten  
 Salvo cambiamenti tecnici  
 Sous réserve de modifications techniques  
 Derechos reservados para efectuar modificaciones técnicas  
 Subject to technical alteration  
 Med förbehåll för tekniska ändringar





# KWC

## 802640

Montage- und Serviceanleitung  
Instructions de montage et d'entretien  
Istruzioni di montaggio e di assistenza  
Instrucciones de montaje y servicio  
Installation and service instructions

Profibrause  
Douchette professionnelle  
Doccia per professionisti  
Ducha profesional  
Professional spray

KWC ONO  
highflex®

EU

Z.535.843.000

Z.535.843.700

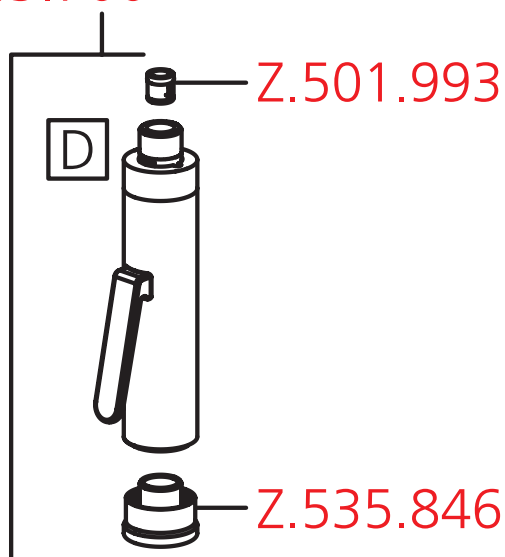

Funktionen  
Fonctions  
Funzioni  
Funciones  
Functions

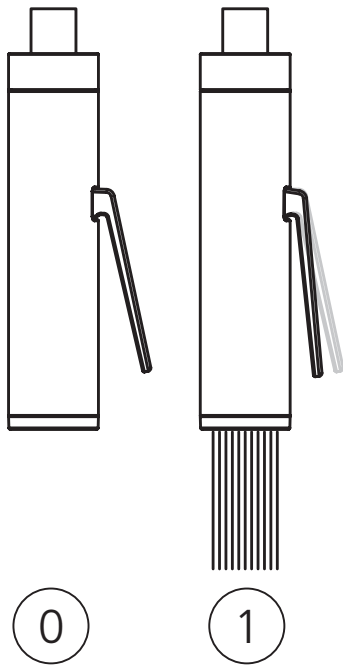

Funktionen  
Fonctions  
Funzioni  
Funciones  
Functions

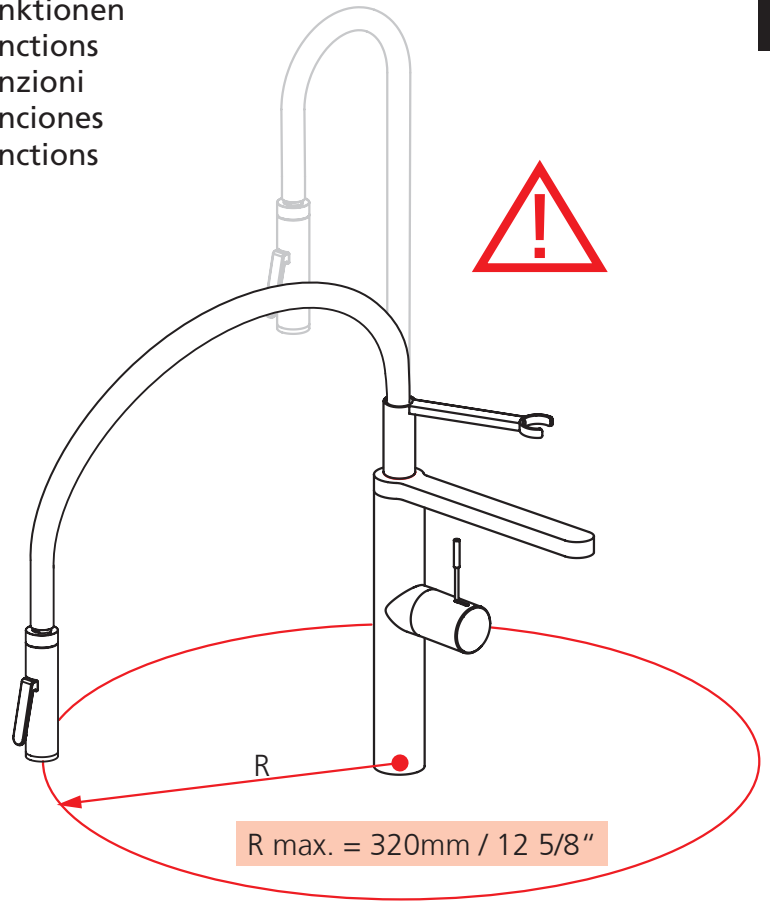

Montage  
Montage  
Montagio  
Montaje  
Installation

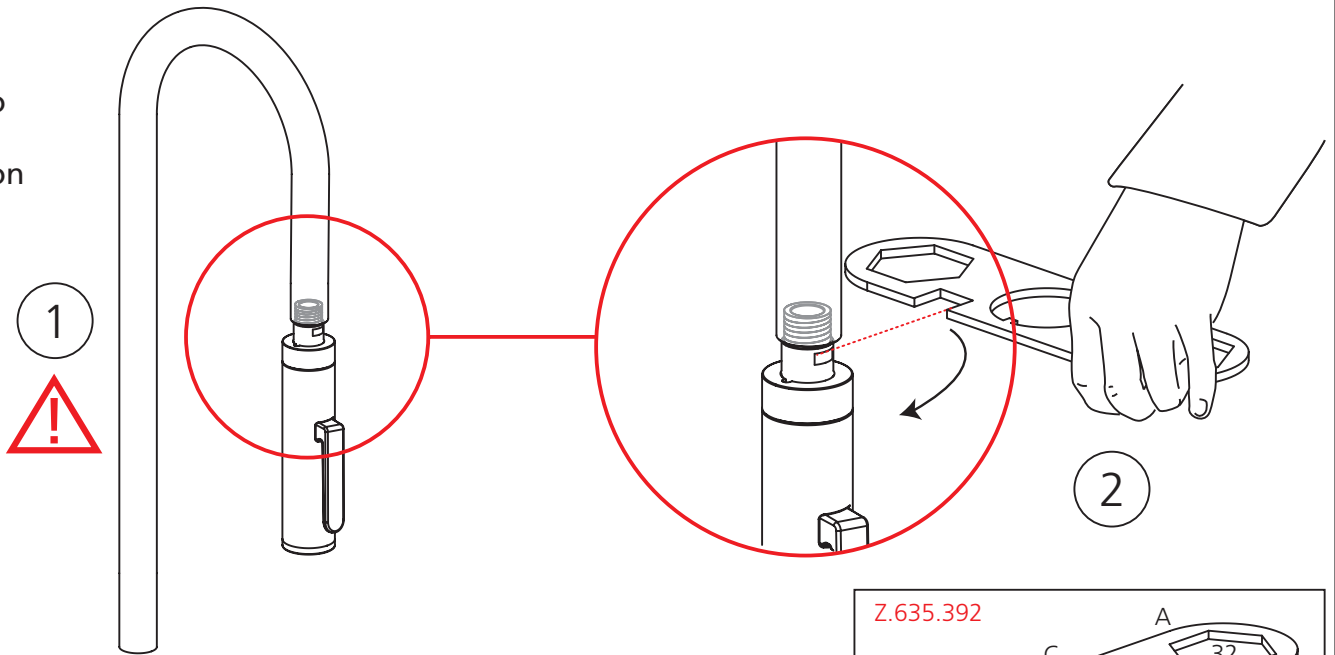

Technische Änderungen vorbehalten  
Salvo cambiamenti tecnici  
Sous réserve de modifications techniques  
Derechos reservados para efectuar modificaciones técnicas  
Subject to technical alteration

KWC VG  
KWC Deutschland GmbH  
Junghansring 70  
DE-72108 Rottenburg  
+49 (0) 7457 948 56 0  
+49 (0) 7457 948 56 30

Franke WS/KS  
Franke S.p.A.  
Via Pignolini 2  
IT - 37019 Peschiera del Garda  
+39 (045) 644 931 1

Franke WS/KS  
Franke Consumer Products  
Luxury Products Group  
800 Aviation Parkway  
Smyrna, TN 37167 USA  
+1 800-626-5771

Franke WS  
Franke GmbH  
Oberer Achdamm 52  
AT-6971 Hard  
+43 (0) 557 467 350  
+43 (0) 557 462 411

Franke WS/KS  
Franke L.L.C.  
RAK Industrial Zone, P.O. Box 14511  
AE-Ras Al Khaimah, UAE  
+971 7 203 47 00  
+971 7 203 47 60

Franke WS  
Franke Water Systems  
Ring-Oost 10  
BE-9400 Ninove  
+32 (0) 54 31 01 30  
+32 (0) 54 31 01 35

Franke KS  
Franke NV  
Ring 10  
BE-9400 Ninove  
+32 (0) 54 31 01 11  
+32 (0) 54 32 36 88