

Features

- Integral soap ledges.
- Single threshold for alcove installation
- Durable acrylic construction.
- Right drain.
- Requires the K-9459 Sonata accessory kit (sold separately).
- Steam compatible with KOHLER steam door and steam generator kit (sold separately).
- Please contact your distributor for this product's pricing information.

Required Products/Accessories

K-9459 Grab Bar and Shelf Accessory Kit

Recommended Products/Accessories

K-1665 Shower Light
K-7166-AF Bath Drain
K-9529 Removable Bath Seat
K-5526 7 kW Steam Generator
K-5557 steam generator control kit



Codes/Standards



CSA B45.5/IAPMO Z124
ASTM E162
ASTM E662

KOHLER® Plastic Baths and Receptors Lifetime Limited Warranty

See website for detailed warranty information.

Available Colors/Finishes

Color tiles intended for reference only.

Color	Code	Description
	0	White
	96	Biscuit
	47	Almond

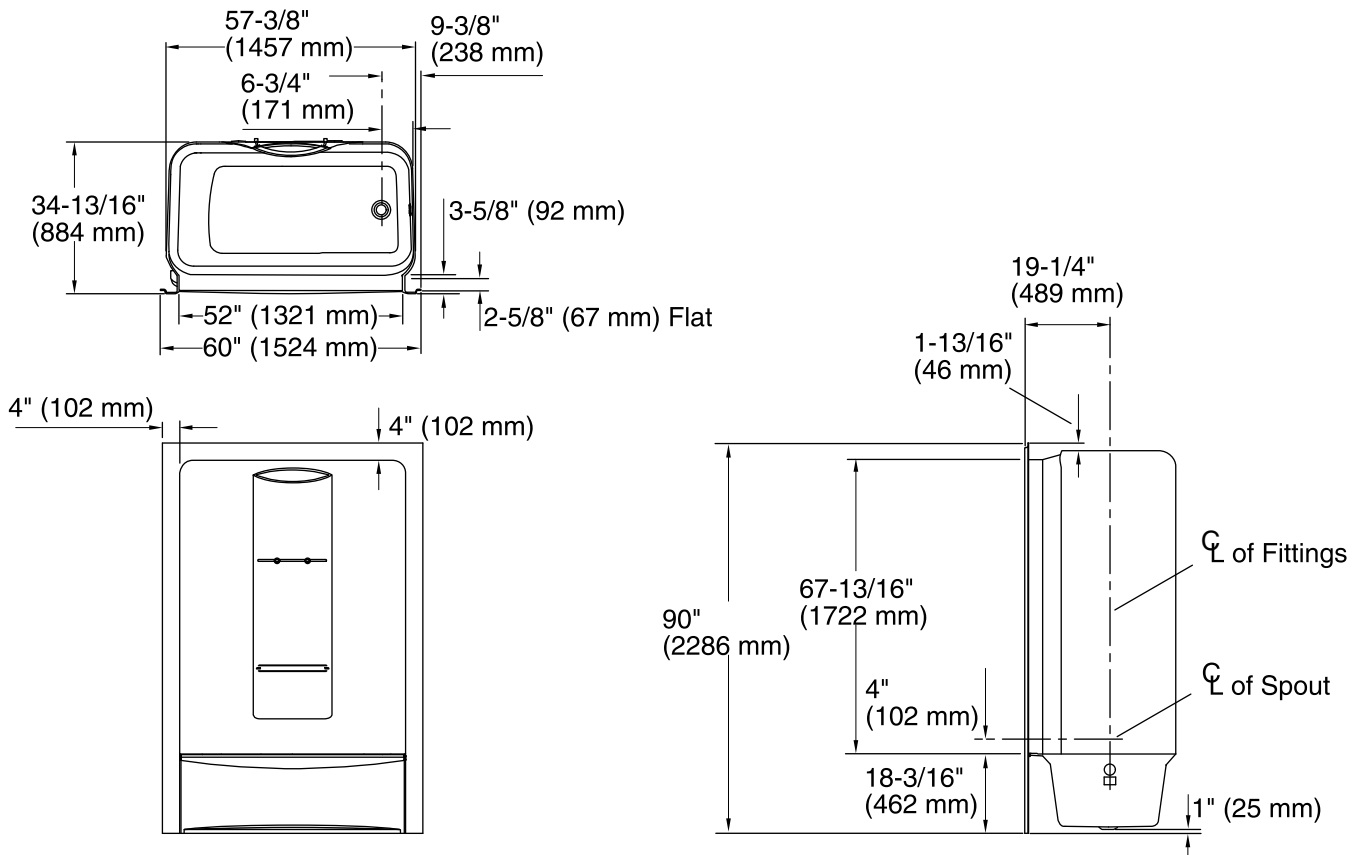

Technical Information

All product dimensions are nominal.

Installation:	Three-wall alcove
Drain location:	Right
Basin area, bottom:	46" x 23" (1168 mm x 584 mm)
Basin area, top:	54" x 27" (1372 mm x 686 mm)
Weight:	200 lbs (90.7 kg)
Minimum floor load:	94 lbs/ft ² (458.9 kg/m ²)
Water depth:	11-7/8" (302 mm)
Water capacity:	55 gal (208.2 L)
Minimum flat for door:	2-1/2" (64 mm)

Notes

Measure your actual product for rough-in details. Install this product according to the installation instructions.

The hot water supply should be 70% of the capacity of the bath or greater. Installations will vary.

KOHLER steam generator/control kit are designed for use with this product. Kohler Co. shall not be responsible for problems encountered due to the installation and use of other manufacturer's steam generators.